

OPERATION AND INSTALLATION

Ground source heat pump

- » HPG-I 04 DS Premium
- » HPG-I 06 DS Premium
- » HPG-I 08 DS Premium
- » HPG-I 12 DS Premium
- » HPG-I 15 DS Premium
- » HPG-I 04 DCS Premium
- » HPG-I 06 DCS Premium
- » HPG-I 08 DCS Premium
- » HPG-I 12 DCS Premium
- » HPG-I 15 DCS Premium

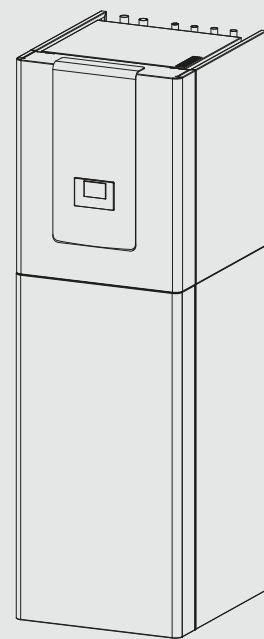

STIEBEL ELTRON

CONTENTS

SPECIAL INFORMATION

OPERATION

1. General information	4
1.1 Relevant documents	4
1.2 Safety instructions	4
1.3 Other symbols in this documentation	4
1.4 Information on the unit	4
1.5 Units of measurement	4
1.6 Standardised output data	4
2. Safety	5
2.1 Intended use	5
2.2 Safety instructions	5
2.3 Test symbols	5
3. Appliance description	5
4. Maintenance and care	6
5. Troubleshooting	6
5.1 Other problems	6

INSTALLATION

6. Safety	6
6.1 General safety instructions	6
6.2 Instructions, standards and regulations	6
7. Appliance description	6
7.1 Function	6
7.2 Standard delivery	6
7.3 Accessories	7
8. Preparation	7
8.1 Safety concept	7
8.2 Installation site	8
8.3 Minimum clearances	8
8.4 Electrical installation	8
9. Installation	9
9.1 Transport	9
9.2 Siting	11
9.3 Opening the appliance	12
9.4 Installing the heat source system	12
9.5 Heating water connection	13
9.6 Oxygen diffusion	14
9.7 Filling the heating system	14
9.8 Venting the heating system	14
9.9 DHW connection	15
9.10 DHW circulation connection	15
9.11 Operation with buffer cylinder	16
9.12 Fitting the push-fit connectors	16
10. Electrical connection	18
10.1 General	18
10.2 Electrical connection	18
10.3 High limit safety cut-out for area heating system	20
10.4 Sensor installation	20
11. Commissioning	20
11.1 Checks before commissioning	20
11.2 Initial start-up	20

12. Appliance handover	21
13. Appliance shutdown	21
13.1 Standby mode	21
13.2 Power interruption	21
14. Troubleshooting	21
14.1 Resetting the high limit safety cut-out	22
14.2 Resetting the compressor tempering device	22
14.3 Checking the IWS DIP switch settings	22
14.4 LEDs (IWS)	23
14.5 Reset button	23
15. Maintenance	23
15.1 DHW cylinders	23
16. Specification	24
16.1 Dimensions and connections	24
16.2 Wiring diagram	26
16.3 Output diagrams	30
16.4 Data table	40

GUARANTEE

ENVIRONMENT AND RECYCLING

SPECIAL INFORMATION

- The appliance may be used by children aged 8 and older and persons with reduced physical, sensory or mental capabilities or a lack of experience and know-how, provided that they are supervised or they have been instructed on how to use the appliance safely and have understood the potential risks. Children must never play with the appliance. Cleaning and user maintenance must not be carried out by children without supervision.
- The connection to the power supply must be in the form of a permanent connection. Ensure the appliance can be separated from the power supply by an isolator that disconnects all poles with at least 3 mm contact separation.
- Maintain the minimum clearances to ensure trouble-free operation of the appliance and facilitate maintenance work.
- In dual mode operation, return water from the second heat generator may flow through the heat pump. Please note that the return water temperature may be a maximum of 65 °C.
- Maintenance work, such as checking the electrical safety, must only be carried out by a qualified contractor.
- We recommend regular inspection (to establish the current condition of the system), and maintenance by a qualified contractor if required (to return the system to its original condition).
- Following disconnection from the power supply, parts of the appliance may remain energised for 5 minutes until the inverter capacitors have discharged.
- Never interrupt the power supply, even outside the heating season. The system's active frost protection is not guaranteed if the power supply is interrupted.
- There is no need to shut the system down in summer. The heat pump manager has an automatic summer/winter changeover.
- Drain the DHW cylinder as described in chapter "Installation / Maintenance / DHW cylinder / Draining the DHW cylinder".
- Install a type-tested safety valve in the cold water supply line. Please note that, depending on the supply pressure, you may also need a pressure reducing valve.
- The safety valve drain aperture must remain open to atmosphere.
- Install the safety valve drain pipe with a constant fall to the drain.
- Size the drain pipe so that water can drain off unimpeded when the safety valve is fully opened.

HPG-I DCS Premium

- The appliance is only suitable for passive cooling.
- In the delivered condition, the COOLING parameter is set to OFF.
- The COOLING menu will only be displayed if a FET is connected. Cooling mode is only possible in summer mode.

OPERATION

1. General information



The chapters "Special information" and "Operation" are intended for both users and qualified contractors.

The chapter "Installation" is intended for qualified contractors.

**Note**

Read these instructions carefully before using the appliance and retain them for future reference. Pass on these instructions to a new user if required.

1.1 Relevant documents

-  Operating instructions for the WPM heat pump manager
-  Commissioning instructions for the WPM heat pump manager
-  Operating and installation instructions for system components

1.2 Safety instructions



1.2.1 Structure of safety instructions

**KEYWORD** Type of risk

Here, possible consequences are listed that may result from failure to observe the safety instructions.

► Steps to prevent the risk are listed.

1.2.2 Symbols, type of risk

Symbol	Type of risk
	Injury
	Electrocution
	Burns (burns, scalding)

1.2.3 Keywords



KEYWORD	Meaning
DANGER	Failure to observe this information will result in serious injury or death.
WARNING	Failure to observe this information may result in serious injury or death.
CAUTION	Failure to observe this information may result in non-serious or minor injury.

1.3 Other symbols in this documentation

**Note**







General information is identified by the adjacent symbol.

► Read these texts carefully.

Symbol	Meaning
	Material losses (appliance damage, consequential losses and environmental pollution)
	Appliance disposal

► This symbol indicates that you have to do something. The action you need to take is described step by step.

1.4 Information on the unit

Symbol	Meaning
	Refrigerant with low flammability
	Inlet / intake
	Drain / outlet
	Heat source
	Heating
	Potable water
	Never cover the appliance

1.5 Units of measurement

**Note**

All measurements are given in mm unless stated otherwise.

1.6 Standardised output data

Information on determining and interpreting the specified standardised output data.

1.6.1 Standard: EN 14511

The output data specifically mentioned in text, diagrams and technical datasheets has been determined in line with the test conditions described in the standard shown in the heading of this chapter. However, there is a partial deviation from this norm in the output data for inverter heat pumps, as this concerns partial load values. The associated percentage weighting in the partial load range can be found in EN 14825 and EHPA quality label regulations.

Generally, the test conditions stated above will not fully match the conditions found at the installation site of the system user.

Depending on the chosen test method and the extent to which this method differs from the test conditions defined in the first paragraph of this section, any deviations can be considerable.

Additional factors that have an influence on the test values are the measuring equipment, the system configuration, the age of the system and the flow rates.

Confirmation of the specified output data can only be obtained if the test conducted for this purpose is also performed in accordance with the test conditions defined in the first paragraph of this section.

2. Safety

2.1 Intended use

The appliance is designed for:

- Heating rooms
- Heating of DHW
- Cooling rooms (only HPG-I DCS Premium)

Observe the operating limits listed in chapter "Specification".

The appliance is intended for domestic use. It can be used safely by untrained persons. The appliance can also be used in non-domestic environments, e.g. in small businesses, as long as it is used in the same way.

Any other use beyond that described shall be deemed inappropriate. Observation of these instructions and of instructions for any accessories used is also part of the correct use of this appliance.

2.2 Safety instructions

- Only recognised, qualified contractors may carry out the electrical work and installation of the heating circuit.
- The qualified contractor is responsible for adherence to all applicable regulations during installation and commissioning.
- The appliance should only be operated once it is fully installed and all safety equipment has been fitted.
- Protect the appliance from dust and dirt during building work.
- Observe the safety concept for operation of the appliance (see chapter "Preparation / Safety concept").



WARNING Injury

The appliance may be used by children over 8 years of age and persons with reduced physical, sensory or mental capabilities or a lack of experience and expertise, provided that they are supervised or they have been instructed on how to use the appliance safely and have understood the potential risks. Children must never play with the appliance. Cleaning and user maintenance must not be carried out by children without supervision.



WARNING Injury

► For safety reasons, only operate the appliance with the casing closed.

2.3 Test symbols

See type plate on the appliance.

3. Appliance description

The appliance is a ground source heat pump suitable for operation as a heating heat pump. The heat pump extracts energy from the heat source medium at a low temperature level. This extracted energy is then transferred to the heating water at a higher level, augmented by the electric energy drawn by the compressor. The heating water is heated to a flow temperature of up to 75 °C, depending on the heat source temperature.

A heating circulation pump, a multifunction assembly (MFG) with safety assembly and a 3-way valve are integrated in the appliance for switching between the heating circuit and the DHW circuit. To heat the DHW, the heating water that has been heated by the heat pump is directed through an indirect coil in the DHW cylinder, where it transfers its energy to the DHW.

The appliance is equipped with an electric emergency/booster heater (NHZ). To safeguard heating operation and the provision of high DHW temperatures, the electric emergency/booster heater is activated as an emergency heater if the dual mode point is undershot in mono mode operation. If the same thing happens in mono energetic operation, the electric emergency/booster heater is activated as a booster heater.

The appliance is controlled with an integral, outside temperature-dependent return temperature control unit (WPM heat pump manager).

The WPM also controls the DHW heating to the required temperature. DHW heating will be completed automatically by an integral electric emergency/booster heater, if either the high pressure sensor or the hot gas limiter of the heat pump responds during DHW heating, subject to the WW LEARNING FUNCTION being deactivated. Also subject to the WW LEARNING FUNCTION being activated, the DHW heating will terminate and the set DHW value will be overwritten with the actual DHW temperature that has been achieved.

The WPM also controls the integral electric emergency/booster heater. An additional heat generator can also be controlled.

Screed drying



Material losses

Incorrect settings can cause damage to the heat pump or screed. With ground source heat pumps, the heat source can also be damaged.

- If you want to use the heat-up program, observe the corresponding chapter in the commissioning instructions for the WPM heat pump manager.

HPG-I DCS Premium



Material losses

In cooling mode, condensate can form when the dew point temperature is undershot.

- Make the electrical connection for the FET remote control.



Material losses

Condensation caused by the temperature falling below the dew point can lead to material losses. The appliance is approved solely for area cooling. Once the FET remote control is connected, the WPM heat pump manager takes control of dew point monitoring.

An additional heat exchanger and 3-way valve for switching between heating and cooling are integrated into the appliance.

Area cooling requires the installation of a remote control unit (FET) in a reference room to capture the relative humidity and the room temperature as part of dew point monitoring.

To cool the living space, the brine is pumped through the additional heat exchanger. There, heat is extracted from the heating water to be released into the cooler zones underground.

The compressor does not run during cooling.

4. Maintenance and care



Material losses

Only qualified contractors may perform maintenance work, such as electrical safety checks.

A damp cloth is sufficient for cleaning all plastic and sheet metal parts. Never use abrasive or corrosive cleaning agents.

We recommend regular inspection (to establish the current condition of the system), and maintenance by a qualified contractor if required (to return the system to its original condition).

5. Troubleshooting

Fault	Cause	Remedy
There is no hot water or the heating system remains cold.	The fuse/MCB has blown/responded.	Check the fuses / MCBs in your fuse box / distribution board.

5.1 Other problems

If you cannot remedy the fault, contact your qualified contractor. To facilitate and speed up your request, provide the number from the type plate. The type plate is located at the front top, on the right or left-hand side of the casing.

Sample type plate

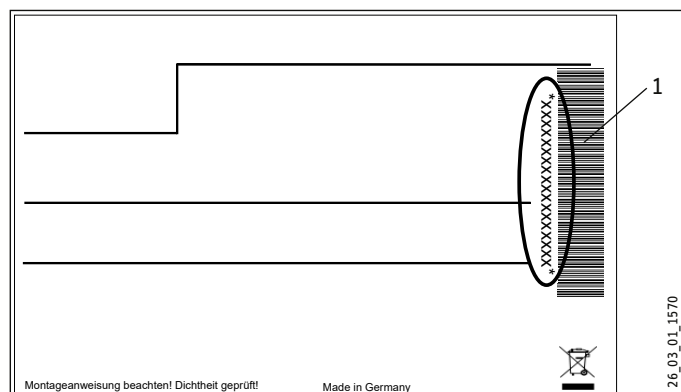

1 Number on the type plate

INSTALLATION

6. Safety

Only a qualified contractor should carry out installation, commissioning, maintenance and repair of the appliance.

6.1 General safety instructions

We guarantee trouble-free function and operational reliability only if original accessories and spare parts intended for the appliance are used.

6.2 Instructions, standards and regulations



Note

Observe all applicable national and regional regulations and instructions.

7. Appliance description

7.1 Function

The heat exchanger on the heat source side (evaporator) extracts natural heat from the heat source. This extracted energy and the energy drawn by the compressor drive is transferred to the heating water by a heat exchanger on the heating water side (condenser). Subject to the heat load, the heating water is heated up to +75 °C. The DHW is heated via the internal indirect coil inside the DHW cylinder.

The electric emergency/booster heater starts if the high pressure sensor or the hot gas limiter responds during DHW heating. If the heat demand of the heating system exceeds the heating output of the heat pump, the emergency/booster heater covers the residual heat demand.

HPG-I DCS Premium

For cooling, the brine is pumped through a 3-way diverter valve and a second heat exchanger. The brine extracts heat from the heating water.

7.2 Standard delivery

- 1x AF PT outside temperature sensor
- 2x TAF PT immersion/contact sensor
- 2x Plastic elbow push-fit connectors 22 mm (for the heating circuit)
- 2x Plastic elbow push-fit connectors 28 mm (for the brine circuit)
- 2x Copper elbow push-fit connectors 22 mm (for the DHW circuit)
- 1x Extraction tool for the copper elbow push-fit connectors
- 2x Pressure hose DN 19 x 500 mm
- 2x Pressure hose DN 25 x 500 mm

INSTALLATION

Preparation

7.3 Accessories

- Brine filling unit WPSF
- Water softening fitting HZEA
- Filter assembly 22 mm (FS-WP 22)
- Filter assembly 28 mm (FS-WP 28)
- FET remote control
- DHW circulation pump UPZ
- TAF PT immersion/contact sensor

8. Preparation

8.1 Safety concept



Never cover the appliance

► Keep the discharge and intake apertures clear.

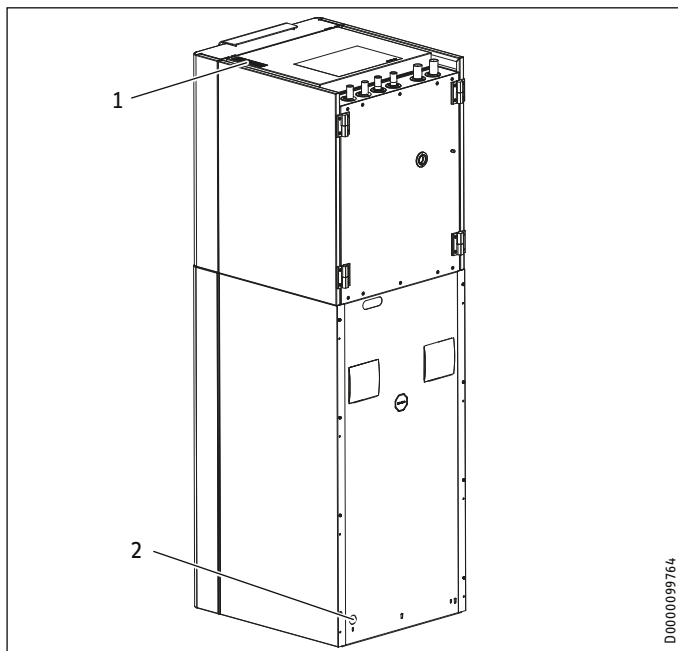

- 1 Discharge aperture
- 2 Intake aperture

A fan is installed in the appliance, which generates a negative pressure in the device. If the negative pressure can no longer be built up (damaged sealing tape), the safety pressure cell shuts down the appliance. A message appears in the heat pump manager.

	Unit	Value
Minimum negative pressure	Pa	30

► Replace the sealing tape if required.

In the event of a leak, the fan mixes the refrigerant gas into the air in the room sufficiently.

► Maintain the minimum installation area of the installation room.

Minimum installation area [m ²]	
HPG-I 04 D(C)S Premium	HPG-I 12 D(C)S Premium
HPG-I 06 D(C)S Premium	HPG-I 15 D(C)S Premium
HPG-I 08 D(C)S Premium	
6.0	8.0

Increasing the minimum installation area

If the minimum installation area requirement cannot be met in the installation room, the installation room can be connected to a neighbouring room via ventilation apertures. The ventilation apertures must be located near the ceiling and the floor. If the ceiling is suspended and there is no wall to the next room, the upper ventilation aperture can be dispensed with.

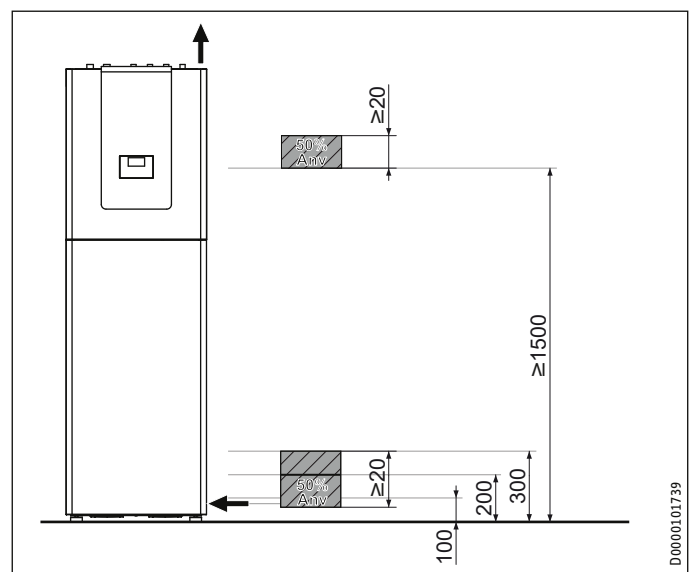

- The ventilation apertures must not be closed.
 - The upper edge of the lower ventilation aperture must be no more than 300 mm above floor level.
 - 50 % of the required ventilation aperture area must be less than 200 mm above floor level.
 - The lower edge of the lower ventilation aperture must be no more than 100 mm above floor level.
 - The ventilation aperture between the rooms must be at least 20 mm wide.
 - A second ventilation aperture is required. The ventilation aperture must be no less than 50 % of the required ventilation aperture area. The lower edge of the ventilation aperture must be at least 1500 mm above floor level.
- Calculate the area of the ventilation apertures.

$$An_v = \frac{m_c - (0,4335 * A)}{50,3}$$

- A Room area [m²]
- An_v Required aperture surface [m²]
- m_c Refrigerant charge [kg]

► Install ventilation apertures corresponding to the calculated area.

INSTALLATION

Preparation

8.2 Installation site



Material losses

- ▶ Install the appliance only in rooms without a constant ignition source (e.g. open flames, a live gas appliance or an electric heater) or without open flue boilers.



Note

The appliance is designed for indoor installation, except in damp areas.

- ▶ Never install the appliance directly below or next to bedrooms.
- ▶ Implement pipe outlets through walls and ceilings with anti-vibration insulation.

The room in which the appliance is to be installed must meet the following conditions:

- No risk from frost
- The room must not be subject to a risk of explosions arising from dust, gases or vapours.
- When installing the appliance in a boiler room together with other heating equipment, ensure that the operation of other heating equipment will not be impaired.
- The minimum volume of the installation room must be observed (see chapter "Preparation / Safety concept").
- Load bearing floor (for the weight of the appliance, see chapter "Specification / Data table").
- ▶ Ensure that the safety valve for the brine circuit is installed in the installation room. Alternatively, outdoor installation is also possible.
- ▶ Ensure that the substrate is level, even, solid and permanent.
- ▶ For installation on floating screeds, make provisions for quiet heat pump operation.
- ▶ Isolate the installation surface around the heat pump by means of a recess. After completing the installation, seal the recess with a waterproof, sound insulating material, such as silicone.

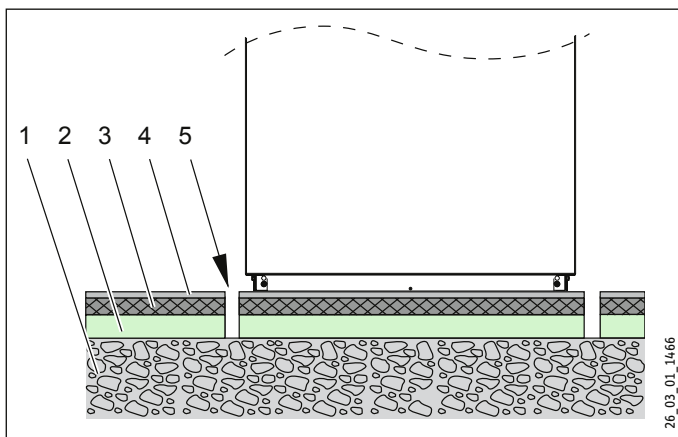

- 1 Concrete base
- 2 Impact sound insulation
- 3 Floating screed
- 4 Floor covering
- 5 Recess

8.3 Minimum clearances

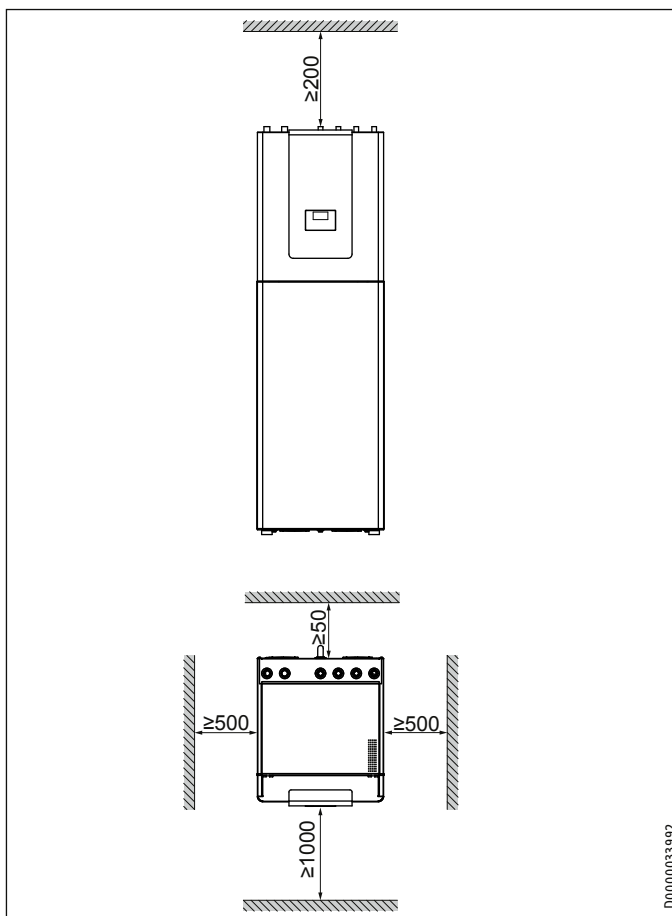

- ▶ Maintain the minimum clearances to ensure trouble-free operation of the appliance and facilitate maintenance work.

8.4 Electrical installation



WARNING Electrocutation

Carry out all electrical connection and installation work in accordance with national and regional regulations.



WARNING Electrocutation

The connection to the power supply must be in the form of a permanent connection. Ensure the appliance can be separated from the power supply by an isolator that disconnects all poles with at least 3 mm contact separation. This requirement can be met by using contactors, circuit breakers, fuses/MCBs, etc.



Material losses

Provide separate fuses/MCBs for the two power circuits, i.e. for the compressor and the electric emergency/booster heater circuits.



Note

The specified voltage must match the mains voltage. Observe the type plate.

INSTALLATION

Installation



Note

The appliance includes an inverter for the variable speed compressor. In the event of an error, inverters can cause DC residual currents. If RCDs are provided, they must be type B AC/DC-sensitive.

A DC residual current can block type A RCDs.

- ▶ Ensure that the appliance power supply is disconnected from the distribution board.

Electrical data is provided in chapter “Specification / Data table”.

- ▶ Use cables with the relevant cross-sections. Observe the applicable national and regional regulations.

HPG-I 04 D(C)S Premium | HPG-I 06 D(C)S Premium | HPG-I 08 D(C)S Premium

Fuse protection	Assignment	Cable cross-section
B 16 A	Compressor	2.5 mm ² for routing through a wall 1.5 mm ² when routing above the surface
B 16 A	Electric emergency/booster heater (BH)	2.5 mm ² 1.5 mm ² with only two live cores and routing on a wall or in an electrical conduit on a wall.
B 16 A	Control unit	1.5 mm ²

HPG-I 12 D(C)S Premium | HPG-I 15 D(C)S Premium

Fuse protection	Assignment	Cable cross-section
B 25 A	Compressor	4.0 mm ² when routing in a wall ≥ 2.5 mm ² when routing above the surface
Alternatively: 1x B 16 A further details below table	Compressor	4.0 mm ² when routing in a wall ≥ 2.5 mm ² when routing above the surface
B 16 A	Electric emergency/booster heater (BH)	2.5 mm ² 1.5 mm ² with only two live cores and routing on a wall or in an electrical conduit on a wall.
B 16 A	Control unit	1.5 mm ²

- ▶ If you have selected a lower fuse protection for the compressor, you will need to limit the maximum power consumption. In the COMMISSIONING / COMPRESSOR menu, adjust the MAXIMUM CURRENT parameter. Observe the information in the commissioning instructions for the heat pump manager.

Heating output with 16 A compressor fuse protection

Source temperature [°C]	Flow temperature [°C]	Heating output [kW]
HPG-I 12 D(C)S Premium		
0	35	12.6
0	55	10.2
HPG-I 15 D(C)S Premium		
0	35	13.4
0	55	10.2

9. Installation

9.1 Transport

- ▶ Transport the appliance in its packaging to protect it against damage.

- ▶ Protect the appliance against heavy impact during transport.
- If the appliance needs to be tilted during transport, this must only be for a short time and it must only be tilted on one of its longitudinal sides.
The longer the appliance is tilted, the greater the distribution of refrigerant oil inside the system.
- Storage and transport at temperatures below - 20 °C and above + 50 °C are not permissible.

To facilitate transportation you can also divide the appliance by removing the refrigeration unit.

9.1.1 Dividing the appliance



Note

When you open the appliance, check the sealing tape. The sealing tape is required for generating the necessary negative pressure.

- ▶ Replace the sealing tape if required.

- ▶ Remove the upper packaging.

Removing the upper front panel

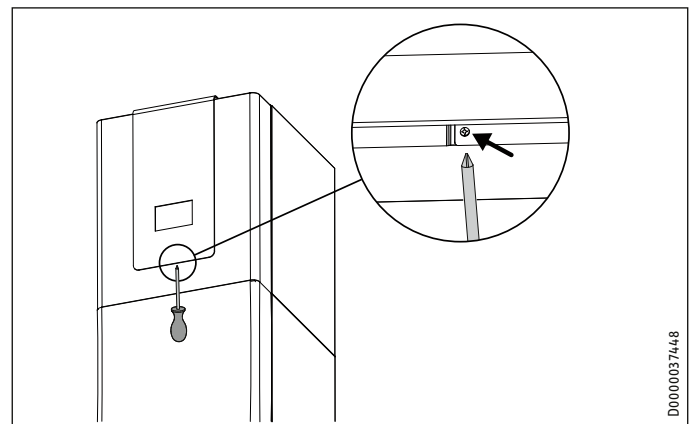

- ▶ Remove the fixing screw from under the fascia.
- ▶ Flip up the upper front panel.

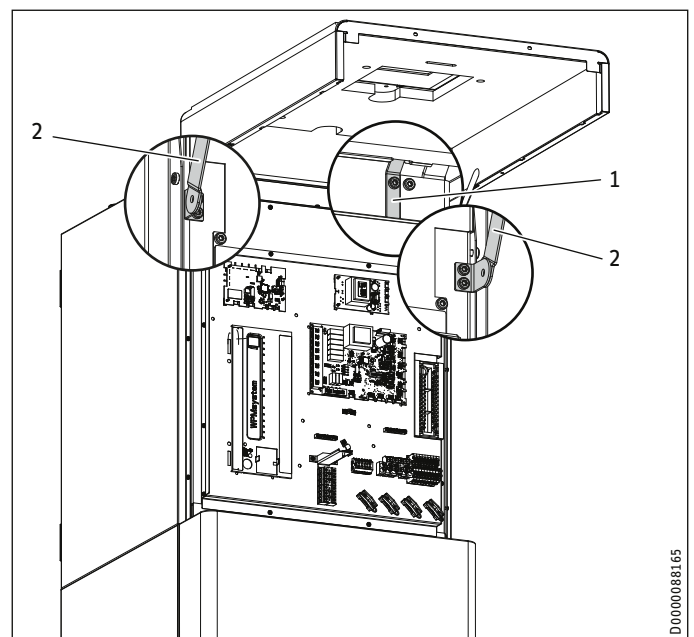

INSTALLATION

Installation

- 1 Hinge closer
 - 2 Articulated joint
- ▶ Unscrew the hinge closer.
 - ▶ Unscrew both articulated joints.
 - ▶ Undo the cable ties and pull the BUS cable connector from the programming unit.
 - ▶ Place the connector safely in the refrigeration unit.

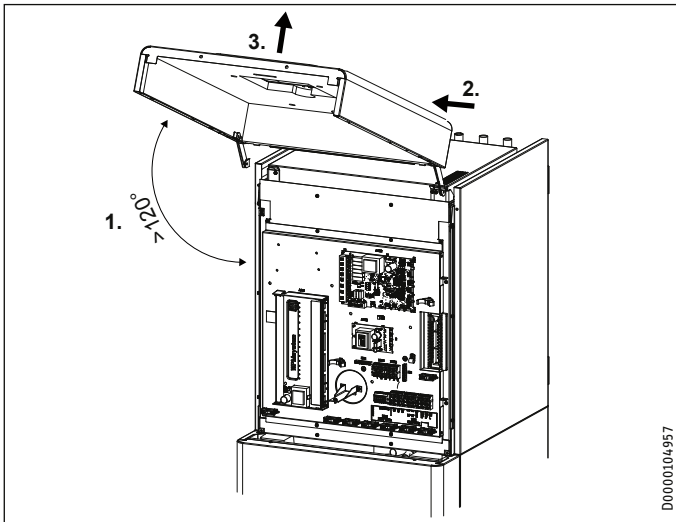

- ▶ Pull off the front panel to the left.

Removing the upper side panels

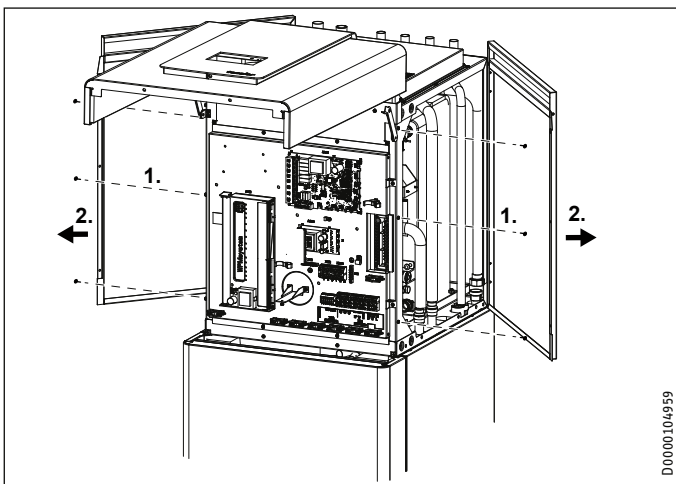

- ▶ Remove the screws.
- ▶ Remove the side panels.

Removing the lower front panel

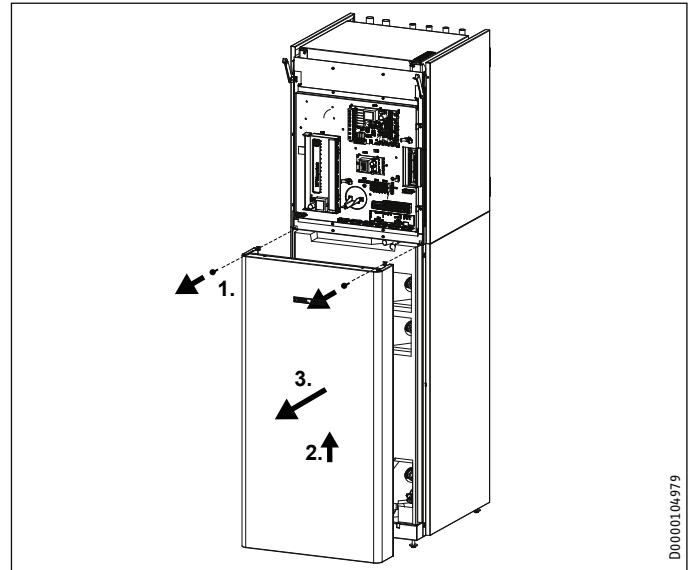

- ▶ Remove the screws from the lower front panel.
- ▶ Remove the lower front panel.

Removing the refrigeration unit

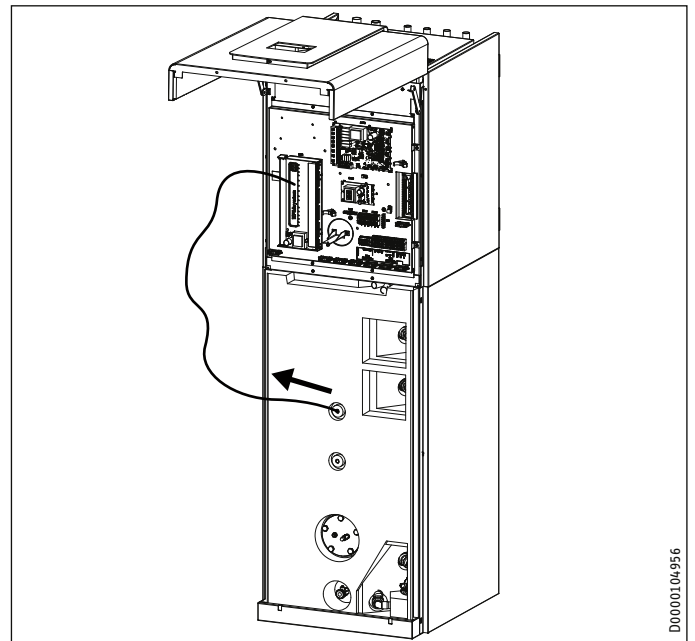

- ▶ Remove the DHW temperature sensor from the immersion pipe of the DHW cylinder.
- ▶ Mark the immersion pipe.
- ▶ Place the DHW temperature sensor safely in the refrigerant circuit.

INSTALLATION

Installation

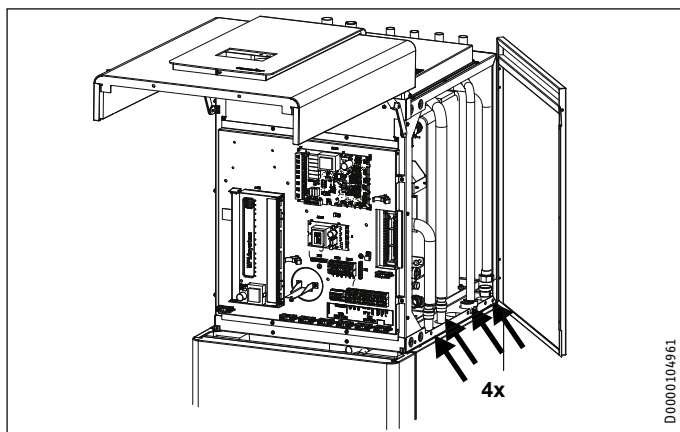

- ▶ Undo the hydraulic connection lines.

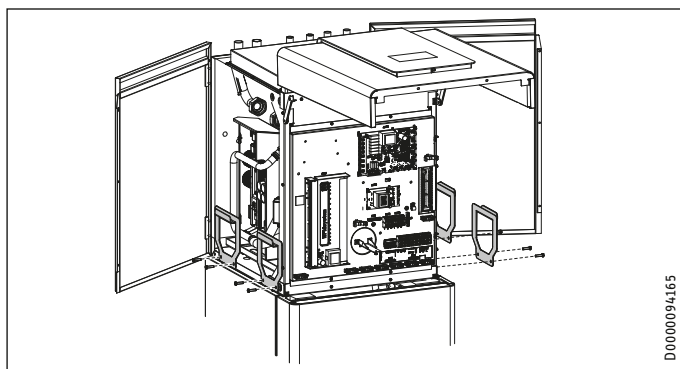

- ▶ Fit the handles.

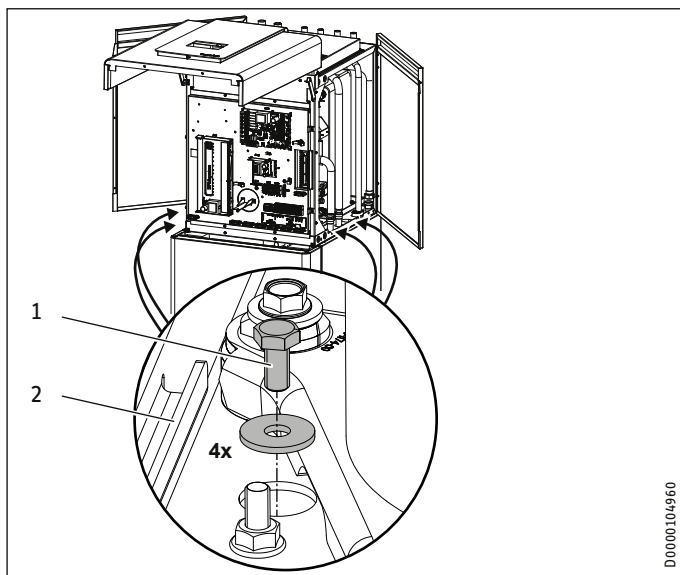

- 1 Fixing screw
- 2 Handle

- ▶ Remove the four fixing screws.
- ▶ Lift the refrigeration unit off the DHW cylinder.
- ▶ Position the DHW cylinder on the prepared base (see chapter "Installation / Siting").
- ▶ Reassemble the appliance in reverse order. Be sure to place the DHW temperature sensor back in the marked sensor well.
- ▶ Remove the handles.

9.2 Siting

- ▶ Remove the packaging film and the top and side EPS padding.

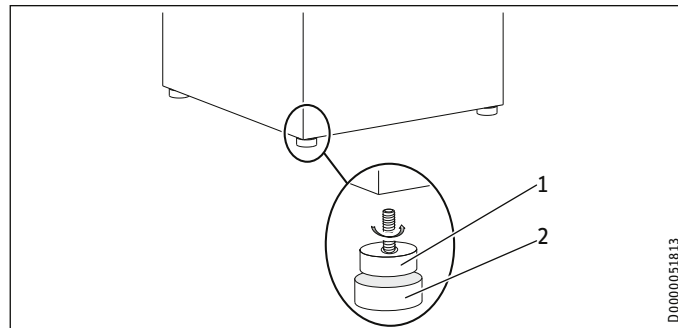

- 1 Appliance foot
- 2 Sliding block

- ▶ Undo the four fixing screws underneath the non-returnable pallet.
- ▶ Remove the appliance feet from the pack.
- ▶ Fully turn the feet onto the appliance, without removing the appliance from the pallet.
- ▶ For lifting, use the handles provided on the back panel and the front adjustable rubber feet at the bottom.
- ▶ Take the appliance off the pallet and set it down on the prepared base. If required, use the sliding blocks provided to help you position the appliance.
- ▶ Observe minimum distances (see chapter "Preparations / Minimum clearances").
- ▶ Level the appliance horizontally by adjusting the feet.

9.3 Opening the appliance



Note

When you open the appliance, check the sealing tape. The sealing tape is required for generating the necessary negative pressure.

- ▶ Replace the sealing tape if required.

- ▶ If necessary, remove the casing parts (see chapter "Installation / Transport / Separating the appliance").

9.4 Installing the heat source system



Material losses

The maximum heat source application limit of 40 °C must not be maintained for more than 30 minutes. Continuous operation with a heat source temperature above the maximum application limit (see chapter "Specification/ Data table") is not permitted.



Note

Engineer the heat source system for the appliance according to the technical guides.

INSTALLATION

Installation



Note

The appliance can also be operated using groundwater as a heat source. An intermediate circuit is required for operation using groundwater.

- ▶ Fit the GWS groundwater module or a heat exchanger.
- ▶ Fill the intermediate circuit with an ethylene glycol/water mixture with at least 25 % by vol. ethylene glycol. Check for leaks.
- ▶ In the heat pump manager, set the source medium to "WATER". The minimum return source temperature is set automatically to +2 °C.

Permitted brine:

		Part number
MEG 10	Heat transfer medium as concentrate on an ethylene glycol base	231109
MEG 30	Heat transfer medium as concentrate on an ethylene glycol base	161696

9.4.1 Circulation pump and required flow rate

The flow rate is automatically controlled by the heat pump manager. The circulation pump cannot be set manually.

9.4.2 Connection and filling with brine

- ▶ Thoroughly flush the pipework with brine before connecting the heat pump to the heat source circuit. Foreign bodies, such as rust, sand and sealant, can impair the operational reliability of the heat pump. We recommend installing our WPSF brine charging unit in the heat source inlet (see chapter "Appliance description / Accessories").

To facilitate easy connection to the brine circuit, the appliance is supplied with push-fit connectors (see chapter "Installation / Fitting push-fit connectors").

- ▶ Connect one flexible pressure hose each to act as an anti-vibration mount to the "heat source flow" and "heat source return" connections. The pressure hoses are part of the standard delivery.

The brine volume of the heat pump under operating conditions can be found in the data table (see chapter "Specification").

The overall volume is equal to the required amount of brine made by mixing undiluted glycol and water. The chloride content of the water must not exceed 100 ppm.

Mixing ratio

The brine concentration varies depending on whether a geothermal collector or a geothermal probe is used as the heat source.

For the mixing ratio see the table below.

	Ethylene glycol	Water
Geothermal probe	25 %	75 %
Geothermal collector	33 %	67 %

Charging the brine circuit



Note

- ▶ Insulate the brine lines with diffusion-proof thermal insulation.

The ground source heat pump is equipped with a brine pressure switch in the brine circuit. If there is a leak in the brine circuit, the brine pressure switch shuts down the appliance and prevents brine getting into the ground.

If the pressure in the brine circuit falls below 0.7 bar, the brine pressure switch turns the heat pump off. In order for the heat pump to be enabled again, the pressure must be raised to at least 1.5 bar while the heat pump is on standby.

To prevent the brine pressure switch turning the heat pump off when there is no leak, charge the heat source side of the heat pump during installation with a minimum pressure of > 1.5 bar.

- ▶ Charge the system according to the following curve to prevent an unintentional response from the brine pressure switch.

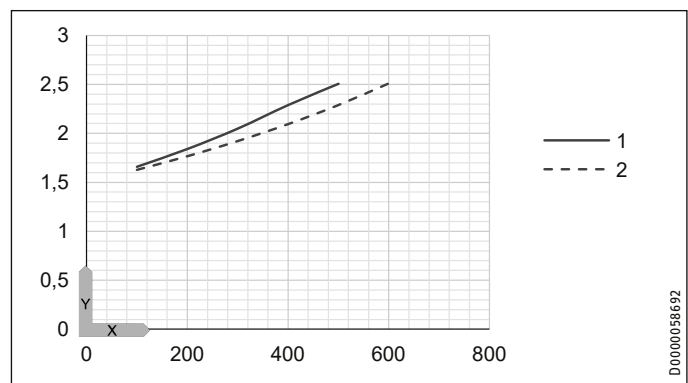

X System volume [l]

Y Charge pressure [bar]

- 1 Required fill pressure depending on system volume at 33 % brine
- 2 Required charge pressure depending on system volume with 25 % brine

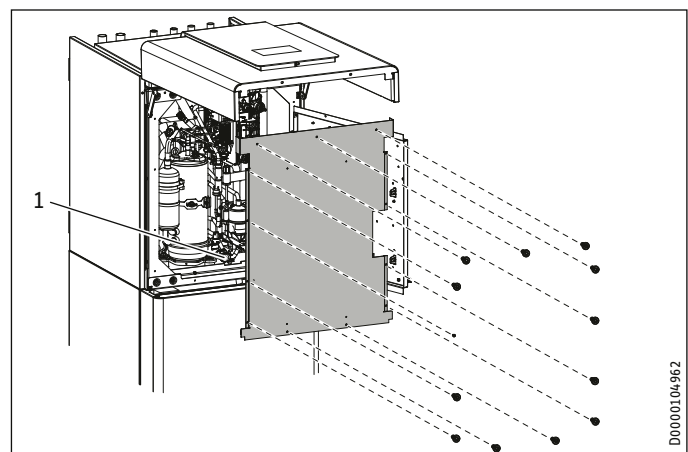

1 Drain, brine side

- ▶ Remove the sealing panel.
- ▶ Fill the brine circuit via the drain.
- ▶ Vent the brine circuit.

INSTALLATION

Installation

Check the brine concentration

- Determine the density of the glycol/water mixture, e.g. with a hydrometer.

Using the actual density and temperature, you can check the actual concentration in the diagram.



Note

The quoted output data relates to ethylene glycol (see "Specification").

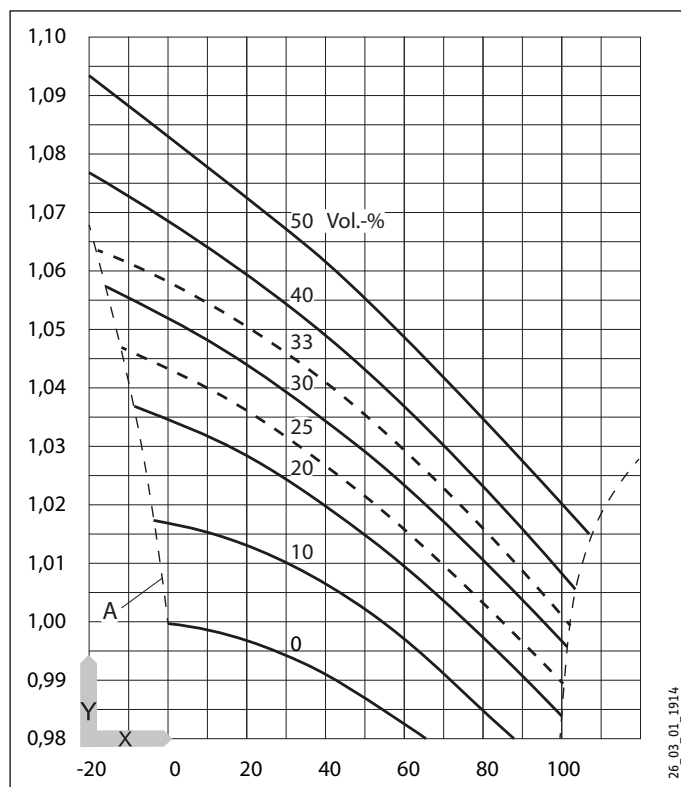

X Temperature [°C]

Y Density [g/cm³]

A Frost protection [°C]

- Insulate the brine pipes with diffusion-proof thermal insulation.

9.5 Heating water connection



Note

The use of non-return valves in the charging circuits between the heat generator and the buffer or DHW cylinder can impair the function of the integral multifunction assembly (MFG) and lead to faults in the heating system.

- Only use our standard hydraulic solutions for the installation of the appliances.

The heating system to which the heat pump is connected must be installed by a qualified contractor in accordance with the water installation diagrams that are part of the technical guides.

- Thoroughly flush the pipework before connecting the heat pump. Foreign bodies, such as rust, sand and sealant, can impair the operational reliability of the heat pump. We recommend installing our filter assembly in the heating return (see chapter "Appliance description / Accessories").

To facilitate easy connection to the heating system, the appliance is supplied with push-fit connectors (see chapter "Installation / Fitting push-fit connectors").

- Connect one flexible pressure hose each to act as an anti-vibration mount to the "heating flow" and "heating return" connections. The pressure hoses are part of the standard delivery.
- Ensure that the heating flow and return are connected correctly.
- Check for tightness.
- When sizing the heating circuit, observe the maximum available external pressure differential (see chapter "Specification / Data table").
- Provide thermal insulation in accordance with applicable regulations.

Safety valve

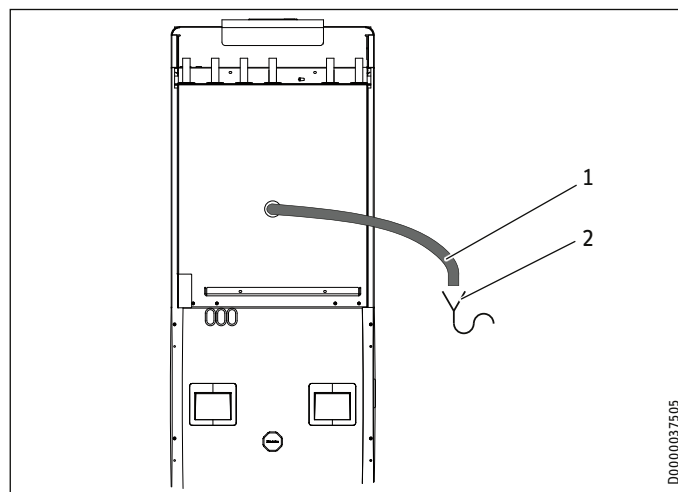

1 Procedure

2 Drain

- Size the discharge outlet so that water can drain off unimpeded when the safety valve is fully opened.
- Ensure that the safety valve drain is open to the outside.
- Install the safety valve drain with a constant fall to the discharge outlet. When installing the drain, never kink the drain hose.

9.6 Oxygen diffusion



Material losses

Do not use open vented heating systems. Use oxygen diffusion-proof pipes in underfloor heating systems with plastic pipework.

In underfloor heating systems with plastic pipes that are permeable to oxygen and in open vented heating systems, oxygen diffusion may lead to corrosion on the steel components of the heating system (e.g. on the indirect coil of the DHW cylinder, on buffer cylinders, steel radiators or steel pipes).

- With heating systems that are permeable to oxygen, separate the heating system between the heating circuit and the buffer cylinder.

INSTALLATION

Installation



Material losses

The products of corrosion (e.g. rusty sludge) can settle in the heating system components, which may result in a lower output or fault shutdowns due to reduced cross-sections.

9.7 Filling the heating system

Heating water quality

Carry out a fill water analysis before filling the system. This analysis may, for example, be requested from the relevant water supply utility.



Material losses

To avoid damage as a result of scaling, it may be necessary to soften or desalinate the fill water. The fill water limits specified in chapter "Specification / Data table" must always be observed.

- ▶ Recheck these limits 8-12 weeks after commissioning and as part of the annual system maintenance.



Note

With a conductivity > 1000 $\mu\text{S}/\text{cm}$, desalination treatment is recommended in order to avoid corrosion.



Note

Suitable appliances for water softening and desalinating, as well as for filling and flushing heating systems, can be obtained from trade suppliers.



Note

If you treat the fill water with inhibitors or additives, the same limits apply as for desalination.

Filling the heating system



Material losses

- ▶ Never switch on the power before filling the system.



Material losses

High flow rates or water hammer can damage the appliance.

- ▶ Fill the appliance at a low flow rate.

In the delivered condition, the diverter valve of the MFG is positioned at the centre. This ensures the heating and DHW circuits are filled equally. If the power is switched on, the diverter valve automatically moves into the central heating position.

If you intend filling or draining the system later, first place the diverter valve into its centre position.

- ▶ Activate the parameter.

Parameter

DRAIN HYD (DIAGNOSIS / RELAY TEST SYSTEM)

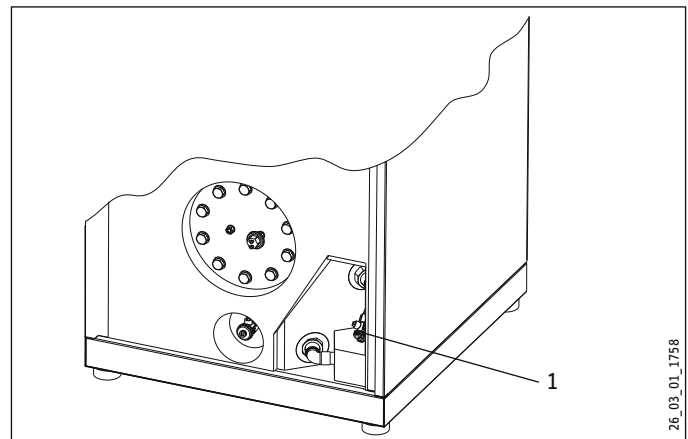

26_03_01_1758

1 Drain, heating side

- ▶ Fill the heating system via the drain.

9.8 Venting the heating system

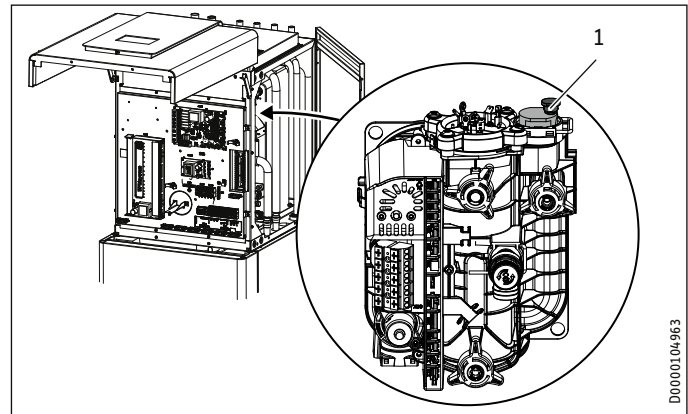

D0000104963

1 Air vent valve

- ▶ Vent the pipework by pulling up the red cap on the air vent valve.
- ▶ Close the air vent valve after the venting process.

9.9 DHW connection

- ▶ Remove the lower front panel (see chapter "Installation / Transport / Separating the appliance / Removing the lower front panel").



Material losses

- ▶ Carry out all water connection and installation work in accordance with regulations.



Material losses

The DHW outlet connection is prefitted with a plastic union nut and a soft rubber gasket. The torque of the plastic union nut depends on the gasket used.

15 Nm = pre-fitted soft rubber gasket.

25 Nm = alternative hard gasket.

- ▶ Keep to the permissible torque.



Material losses

- ▶ Operate the appliance only with pressure-tested taps.

INSTALLATION

Installation

9.9.1 Permissible materials

Cold water line

Galvanised steel, stainless steel, copper and plastic are approved materials.

DHW line

Stainless steel, copper and plastic pipework are approved.



Material losses

The maximum permissible pressure must not be exceeded (see chapter "Specification / Data table").

- ▶ Install a type-tested safety valve in the cold water supply line. Please note that, depending on the supply pressure, you may also need a pressure reducing valve.
- ▶ The safety valve drain aperture must remain open to atmosphere.
- ▶ Install the safety valve drain pipe with a constant fall to the drain.
- ▶ Size the discharge outlet so that water can drain off unimpeded when the safety valve is fully opened.
- ▶ Flush the pipes thoroughly.

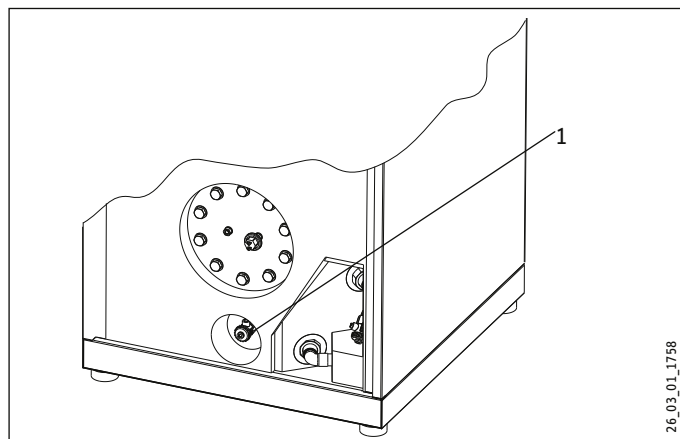

1 Drain (DHW cylinder)

- ▶ Fill the DHW cylinder via the drain.
- ▶ Open all downstream draw-off points until the appliance is full and the pipework is free of air.
- ▶ Carry out a tightness check.

9.10 DHW circulation connection

DHW circulation is not recommended for reasons of poor energy efficiency. If DHW circulation is required due to unfavourable pipework or for reasons of convenience, you must install the DHW circulation in accordance with applicable standards. To reduce pump runtime and energy demand, we recommend imposing time and temperature controls on activation of the DHW circulation pump. The DHW circulation connector is located at the back of the appliance (see chapter "Specification / Dimensions and connections").

A DHW circulation pump can be found in our range of accessories.

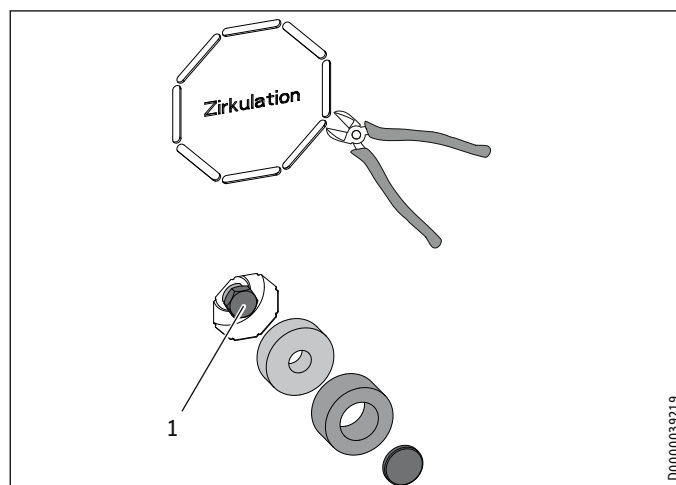

1 Cap

- ▶ Detach the panel.
- ▶ Remove the foam parts.
- ▶ Unscrew the cap.
- ▶ Reinsert the foam parts.
- ▶ Connect the DHW circulation line.

INSTALLATION

Installation

9.11 Operation with buffer cylinder

- ▶ Install the supplied TAF PT immersion/contact sensor.
- ▶ Connect the sensor to the heat pump manager.
- ▶ Adjust the parameter.

Parameter	Setting
BUFFER OPERATION (SETTINGS / HEATING / STANDARD ON SETTINGS)	ON

HPG-I DCS Premium

For cooling in combination with a buffer cylinder, an additional TAF PT immersion / contact sensor is required.

- ▶ Install the sensor in the buffer cylinder flow.
- ▶ Connect the sensor to the heat pump manager.

9.12 Fitting the push-fit connectors

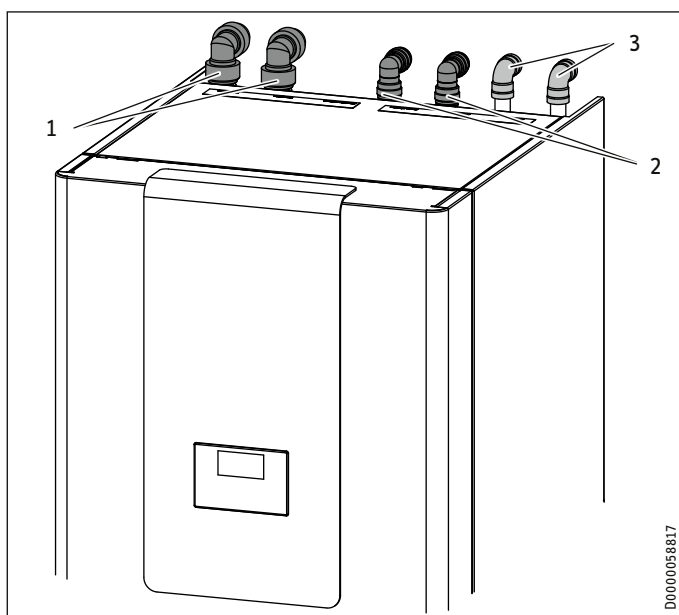

- 1 Plastic push-fit connectors, heat source side
- 2 Plastic push-fit connectors, heating side
- 3 Copper push-fit connectors, DHW side

9.12.1 Installing plastic push-fit connectors (heating side and heat source side)



Note

The plastic push-fit connectors are not suitable for installation in the DHW line.

- ▶ Only install the push-fit connectors in the heating or brine circuits.



Material losses

- ▶ Tighten the screw cap of the push-fit connector by hand. Never use a tool.



Material losses

To ensure the push-fit connector is held securely, pipes with a surface hardness > 225 HV (e.g. stainless steel) must have a groove.

- ▶ Using a pipe cutter, cut a groove (depth approx. 0.1 mm) at a defined distance from the end of the pipe.
 - Pipe diameter 22 mm: 17±0.5 mm
 - Pipe diameter 28 mm: 21±0.5 mm



Material losses

Support sleeves are required when using plastic pipes.

How the push-fit connectors work

The push-fit connectors are equipped with a retainer with stainless steel serrations and an O-ring for sealing. In addition, the push-fit connectors are equipped with the "twist and lock" function. Simply turning the screw cap by hand will secure the pipe in the connector and push the O-ring against the pipe to seal it.

Making the push-fit connection

The connector must be in its relaxed position before the pipe is inserted. In this position, there is a small gap between the screw cap and main body.

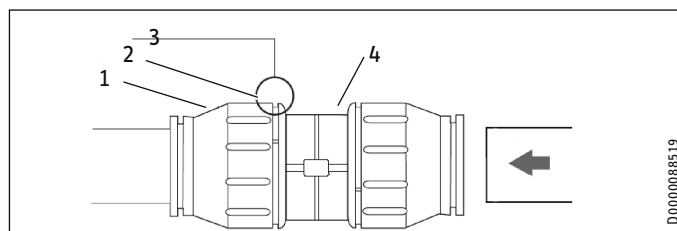

- 1 Retainer
- 2 Screw cap
- 3 Gap between screw cap and main body
- 4 Main body

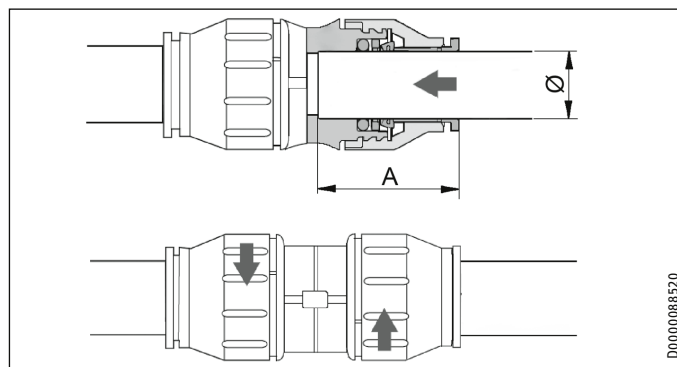

Pipe Ø	22 mm	28 mm
Depth of insertion A	max. 38 mm	max. 44 mm



Material losses

- ▶ Pipe ends must be deburred.
 - ▶ Always use a pipe cutter to trim pipes.

- ▶ Push the pipe past the O-ring into the push-fit connector until it reaches the prescribed insertion depth.

INSTALLATION

Installation

- ▶ Finger-tighten the screw cap as far as it will go against main body. This secures the push-fit connection.

Undoing the push-fit connection

If the push-fit connectors later need to be undone, proceed as follows:

- ▶ Turn the screw cap anti-clockwise until there is a narrow gap of approx. 2 mm. Press the retainer back with your fingers and hold on to it.
- ▶ Pull out the inserted pipe.

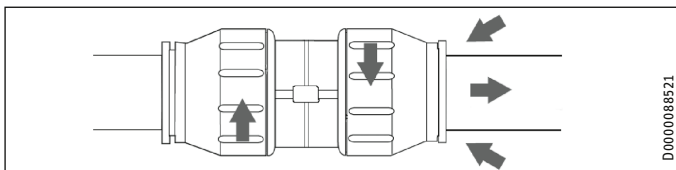

9.12.2 Installing copper push-fit connectors (DHW side)



Note

The copper push-fit connectors are only designed for use in the DHW line.



Material losses

To ensure the push-fit connector is held securely, pipes with a surface hardness > 225 HV (e.g. stainless steel) must have a groove.

- ▶ Using a pipe cutter, cut a groove (depth approx. 0.1 mm) at a defined distance from the end of the pipe.
- Pipe diameter 22 mm: 12±0.5 mm



Material losses

- ▶ Push the pipe into the push-fit connector by hand. Never use a tool.

How the push-fit connectors work

The push-fit connectors are equipped with a retainer with stainless steel serrations and an O-ring for sealing. Simply pushing it in by hand secures the pipe in the connector and presses the O-ring against the pipe to seal it.

An extraction tool is necessary to release the connection.

Making the push-fit connection



Material losses

- Pipe ends must be deburred.
- ▶ Always use a pipe cutter to trim pipes.

- ▶ Push the pipe past the O-ring into the push-fit connector until it reaches the prescribed insertion depth.

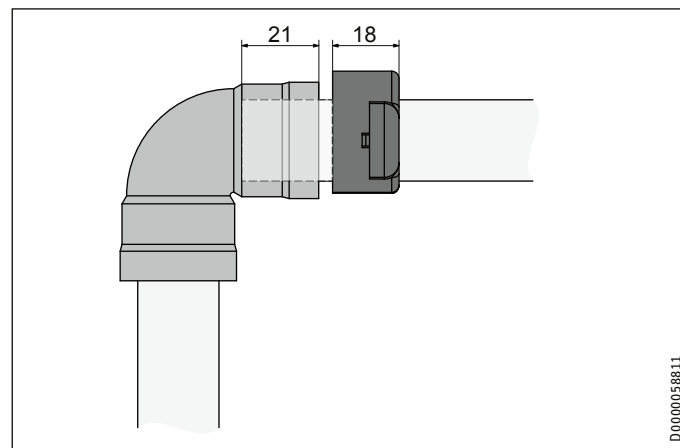

- ▶ Leave sufficient clearance for the extraction tool.

Undoing the push-fit connection

If the push-fit connectors later need to be undone, proceed as follows:

- ▶ Use the extraction tool provided to release the push-fit connection.

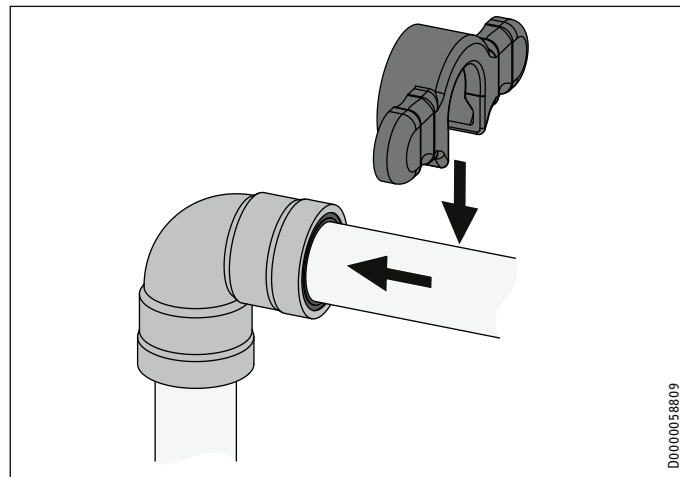

- ▶ Position the extraction tool at the push-fit connector.

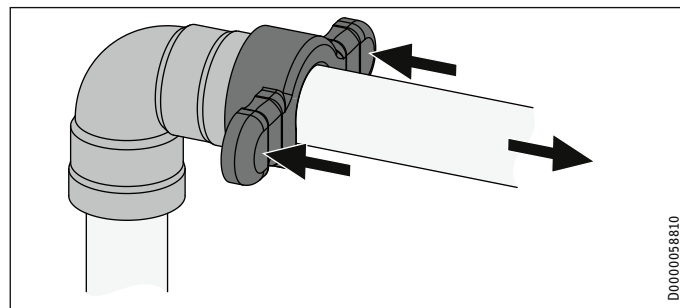

- ▶ Push the edge of the extraction tool against the push-fit connector.
- ▶ Pull out the inserted pipe.

10. Electrical connection

10.1 General



WARNING Electrocutation

► Before working on the appliance, isolate it from the power supply at the control panel.



Note

The leakage current of this appliance can be > 3.5 mA.



Note

In conjunction with the WPM heat pump manager, use the HSM mixer servomotor.

Connection work must only be carried out by a qualified contractor and in accordance with these instructions.

You must have permission to connect the appliance from the relevant power supply utility (PSU).

► See chapter "Preparation / Electrical installation".

10.2 Electrical connection



Note

► Fill the heating system before making the electrical connection (see chapter "Installation / Heating water connection").

The terminals are located at the appliance control panel behind the upper panel.

For all connections, use appropriate cables in accordance with local regulations.

► Route all cables and sensor leads through the entries provided in the back panel (see chapter "Specification / Dimensions and connections").

You must be able to open the control panel during maintenance and repair work (see chapter "Installation / Venting the heating system").

- Ensure an adequate length of cables and sensor leads.
- Route the cables and leads through the cable ties.
- Route cables and leads through the strain relief fittings.
- Check that the strain relief fittings are working as intended.

10.2.1 Compressor and electric emergency/booster heater

Appliance function	Effect of the electric emergency/booster heater
Mono energetic operation	If the dual mode point is undershot, the electric emergency/booster heater safeguards both the heating operation and the provision of high DHW temperatures.
Emergency mode	If the heat pump shuts down due to a fault, the heating output is covered by the electric emergency/booster heater.

You can choose between two connection options. The compressor connection remains single-phase.

Connection option	Connection type
A	separate connections for compressor and emergency/booster heater
B	connection for compressor and emergency/booster heater using a 5-core cable

Connection option A (230 V)

► Connect the cables according to the following diagram.

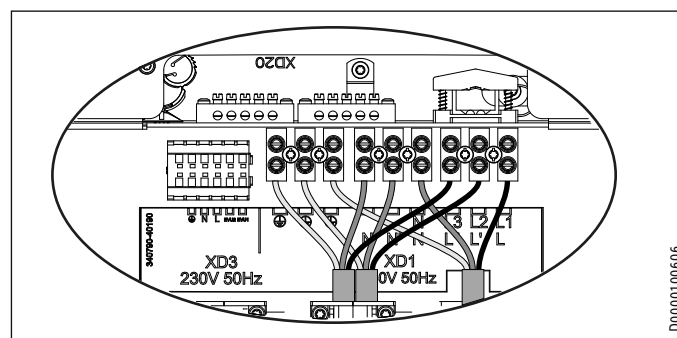

XD1 Compressor (inverter)

L, N, PE

XD1 Electric emergency/booster heater (NHZ)

L', L'', N', N'', PE

XD3 Control voltage

L, N, PE

► Route cables and leads through the strain relief fittings. Check that the strain relief fittings are working as intended.

If no voltage is applied to the power supply utility enable signal, the heat pump will not start.

► If no ripple control receiver is fitted, install a jumper between EVU1 and EVU2.

Connection option B (400 V)

► Connect the cables according to the following diagram.

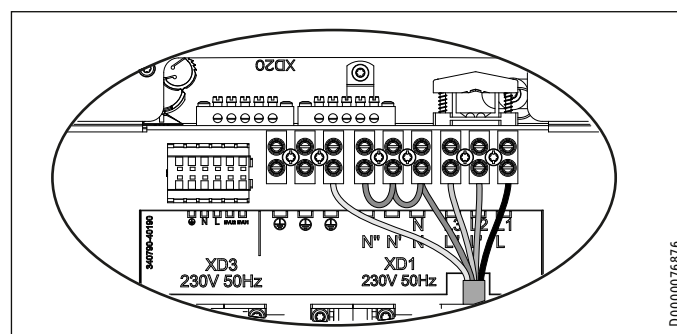

XD1 Compressor (inverter)

Electric emergency/booster heater (NHZ)

L1, L2, L3, N, PE

XD3 Control voltage

L, N, PE

► Connect the N, N', and N'' connections with a jumper.
 ► Route cables and leads through the strain relief fittings. Check that the strain relief fittings are working as intended.

Electrical connection

If no voltage is applied to the power supply utility enable signal, the heat pump will not start.

- If no ripple control receiver is fitted, install a jumper between EVU1 and EVU2.

10.2.2 Heat pump manager terminal assignment

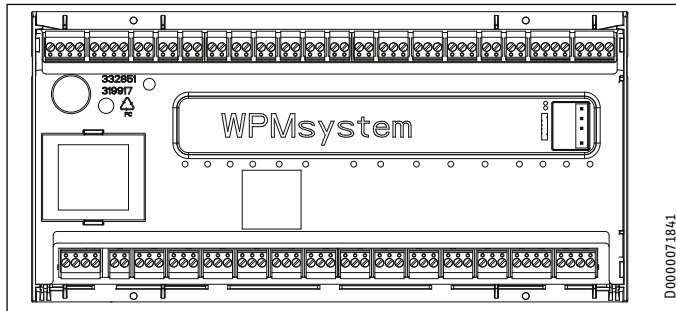

Safety extra low voltage

X1.1	+	+	CAN (connection for heat pump and WPE heat pump extension)
CAN A	-	-	
	L	L	
	H	H	
X1.2	+	+	CAN (internal programming unit)
CAN B	-	-	
	L	L	
	H	H	
X1.3	Signal	1	Outside sensor
	Earth	2	
X1.4	Signal	1	Buffer sensor (heating circuit sensor 1)
	Earth	2	
X1.5	Signal	1	Flow sensor
	Earth	2	
X1.6	Signal	1	Heating circuit sensor 2
	Earth	2	
X1.7	Signal	1	Heating circuit sensor 3
	Earth	2	
X1.8	Signal	1	DHW cylinder sensor
	Earth	2	
X1.9	Signal	1	
	Earth	2	
X1.10	Signal	1	2nd heat generator (2.WE)
	Earth	2	
X1.11	Signal	1	Cooling flow
	Earth	2	
X1.12	Signal	1	DHW circulation sensor
	Earth	2	
X1.13	Signal	1	FE7 remote control / telephone remote switch / heating curve optimisation / SG Ready
	Earth	2	
	Signal	3	
X1.14	Constant 12 V	+	Analogue input 0-10 V
	Input	IN	
	GND	⊥	
X1.15	Constant 12 V	+	Analogue input 0-10 V
	Input	IN	
	GND	⊥	
X1.16	Signal	1	PWM output 1
	Earth	2	
X1.17	Signal	1	PWM output 2
	Earth	2	
X1.18	+	+	CAN (connection for FET remote control and ISG Internet Service Gateway)
CAN B	-	-	
	L	L	
	H	H	
X1.19	+	+	CAN (connection for heat pump and WPE heat pump extension)
CAN A	-	-	
	L	L	
	H	H	

Mains voltage

X2.1	L	L	Power supply
	L	L	
	N	N	
	PE	⊕ PE	
X2.2	L' (power supply utility input)	L'	L' (power supply utility input)
	L* (pumps L)	L* (pumps L)	L* (pumps L)
X2.3	L	L	Heating circuit pump 1
	N	N	
	PE	⊕ PE	
X2.4	L	L	Heating circuit pump 2
	N	N	
	PE	⊕ PE	
X2.5	L	L	Heating circuit pump 3
	N	N	
	PE	⊕ PE	
X2.6	L	L	Buffer charging pump 1
	N	N	
	PE	⊕ PE	
X2.7	L	L	Buffer charging pump 2
	N	N	
	PE	⊕ PE	
X2.8	L	L	DHW charging pump
	N	N	
	PE	⊕ PE	
X2.9	L	L	Source pump / defrost
	N	N	
	PE	⊕ PE	
X2.10	L	L	Fault output
	N	N	
	PE	⊕ PE	
X2.11	L	L	DHW circulation pump / 2nd heat source DHW
	N	N	
	PE	⊕ PE	
X2.12	L	L	2nd heat source heating
	N	N	
	PE	⊕ PE	
X2.13	L	L	Cooling
	N	N	
	PE	⊕ PE	
X2.14	Mixer OPEN	▲	Mixer, heating circuit 2 (X2.14.1 Mixer OPEN X2.14.2 Mixer CLOSE)
	N	N	
	PE	⊕ PE	
	Mixer CLOSE	▼	
X2.15	Mixer OPEN	▲	Mixer heating circuit 3 (X2.15.1 Mixer OPEN X2.15.2 Mixer CLOSE)
	N	N	
	PE	⊕ PE	
	Mixer CLOSE	▼	



Note

For every appliance fault, output X2.10 issues a 230 V signal.

In the case of temporary faults, the output switches the signal through for a specific time.

In the case of faults that result in a permanent appliance shutdown, the output switches through permanently.

- You can define the characteristics of the output via parameter "COMMISSIONING / I/O CONFIGURATION / OUTPUT X 2.10".

INSTALLATION

Commissioning

10.3 High limit safety cut-out for area heating system



Material losses

In order to prevent excessively high flow temperatures in the area heating system causing damage in the event of a fault, install a high limit safety cut-out to limit the system temperature.

10.4 Sensor installation

- ▶ When installing a sensor, follow the commissioning instructions for the heat pump manager (see chapter "Connecting external components").

11. Commissioning

Only a qualified contractor may adjust the settings in the commissioning instructions for the heat pump manager, commission the appliance and instruct the operator in its use.

Carry out commissioning in accordance with these operating and installation instructions, and the instructions for the heat pump manager. Our customer support can assist with commissioning, which is a chargeable service.

If this appliance is intended for commercial use, observe the rules of the relevant Health & Safety at Work Act during commissioning. For further details, check with your local authorising body (e.g. TÜV).

11.1 Checks before commissioning

- ▶ Before commissioning check the points detailed below.

11.1.1 Heating system

- Have you filled the heating system to the correct pressure?
- Have you closed the automatic air vent valve of the multifunction assembly (MFG) after venting?



Material losses

- ▶ Observe the maximum system temperature in underfloor heating systems.

11.1.2 Heat source



Material losses

If screed drying is carried out with a ground source heat pump, the heat source can be overloaded, especially a geothermal probe. The ground around the geothermal probe may freeze in the process. Heat transfer to the ground will be irreparably damaged.

- ▶ Observe the chapter "Menu structure / PROGRAMS menu / HEAT-UP PROGRAM" in the commissioning instructions for the heat pump manager.

The appliance is equipped with a source protection function. If the temperature falls below a defined brine temperature, the appliance automatically reduces the power.

11.1.3 Temperature sensors

- Have you correctly positioned and connected the outside sensor and the immersion/contact sensor (in conjunction with a buffer cylinder)?

11.1.4 High limit safety cut-out

At ambient temperatures below -15 °C, the high limit safety cut-out of the multifunction assembly may respond.

- ▶ Check whether the high limit safety cut-out has tripped.

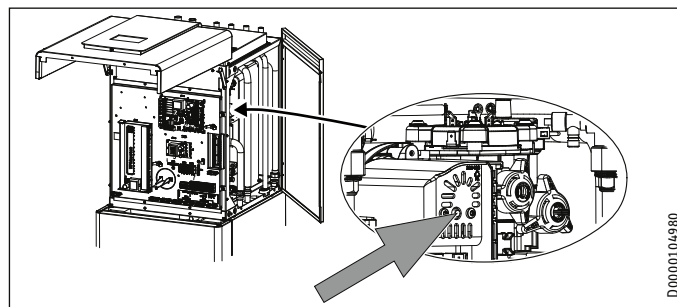

- ▶ Reset the high limit safety cut-out by pressing the reset button.

11.1.5 Power supply

- Have you correctly connected the power supply?

11.2 Initial start-up

11.2.1 Activating spread control



Note

- ▶ For cooling, use the constant flow rate (default setting).

- ▶ To adapt the appliance to your requirements, activate spread control.

Parameter	Setting
SPREAD CONTROL (COMMISSIONING / CHARGING PUMP CONTROL / HEATING / TYPE OF CONTROL)	ON
SPREAD CONTROL (COMMISSIONING / CHARGING PUMP CONTROL / DHW / TYPE OF CONTROL)	ON

For spread control we recommend the following settings.

Parameter	Setting [K]
SPREAD (COMMISSIONING / CHARGING PUMP CONTROL / HEATING / SET POINTS)	8
SPREAD (COMMISSIONING / CHARGING PUMP CONTROL / DHW / SET POINTS)	8

11.2.2 Heating curve adjustment

The efficiency of a heat pump decreases as the flow temperature rises. Adjust the heating curve carefully. Heating curves that are set too high cause the zone valves or thermostatic valves to close, which may result in the minimum required flow rate in the heating circuit being undershot.

- ▶ Observe the WPM commissioning instructions.

The following steps will help you to adjust the heating curve correctly:

Appliance handover

- ▶ Fully open thermostatic or zone valves in a lead room (e.g. living room or bathroom).
We do not recommend installing thermostatic or zone valves in the lead room. Control the temperature for these rooms via a remote control.
- ▶ At different outside temperatures (e.g. -10 °C and $+10\text{ °C}$), adjust the heating curve so that the required temperature is set in the lead room.

Standard values to begin with:

Parameter	Underfloor heating	Radiator heating system
Heating curve	0.4	0.8
Control dynamic	100	100
Comfort temperature	20 °C	20 °C

- ▶ If the room temperature in spring and autumn is too low (approx. 10 °C outside temperature), raise the comfort temperature.

Parameter
COMFORT TEMPERATURE (SETTINGS / HEATING / HEATING CIRCUIT)



Note
If no remote control is installed, raising the comfort temperature leads to a parallel offset of the heating curve.

- ▶ If the room temperature is not high enough at low outside temperatures, increase the heating curve.

Parameter
HEATING CURVE RISE (SETTINGS / HEATING / HEATING CIRCUIT)

- ▶ If the heating curve has been raised and no remote control has been installed in the lead room, adjust the zone valve or thermostatic valve in the lead room to the required temperature when outside temperatures are high.



Note
▶ Never reduce the temperature in the entire building by closing all zone or thermostatic valves; instead use the setback programs.

- ▶ Once everything has been implemented correctly, the system can be heated to its maximum operating temperature and vented once again.



Material losses
▶ For underfloor heating systems, observe the maximum permissible temperature for that particular underfloor heating.

11.2.3 Other settings

- ▶ For additional settings, note the information in the WPM commissioning instructions.

Parameter
BUFFER OPERATION (SETTINGS / HEATING / STANDARD SETTING)
WW OUTPUT SUMMER (SETTINGS / DHW / STANDARD SETTING)
WW OUTPUT WINTER (SETTINGS / DHW / STANDARD SETTING)
COOLING (SETTINGS)

12. Appliance handover

Explain the appliance function to users and familiarise them with how it works.



Note
▶ Hand over these operating and installation instructions to the user for safe-keeping. All information in these instructions must be closely observed. The instructions provide information on safety, operation, installation and maintenance of the appliance.

13. Appliance shutdown



Material losses
Never interrupt the heat pump power supply, even outside of the heating season. Otherwise, system frost protection is not guaranteed.
The heat pump manager automatically switches the heat pump to summer or winter mode.



Material losses
▶ Observe the temperature application limits and the minimum circulation volume on the heat consumer side (see chapter "Specification / Data table").

13.1 Standby mode

To shut the system down, simply set the heat pump manager to "Standby mode". This way, the safety functions that protect the system remain enabled, e.g. frost protection.

13.2 Power interruption

If the system is to be isolated from the power supply permanently, please observe the following:



Material losses
▶ If the heat pump is completely switched OFF and there is a risk of frost, drain the system on the water side.

14. Troubleshooting



WARNING Electrocutation
▶ Before working on the appliance, isolate it from the power supply at the terminal area.
Following disconnection from the power supply, parts of the appliance may remain energised for 5 minutes until the inverter capacitors have discharged.



Note
▶ Please observe the instructions for the heat pump manager.



Note
The following inspection instructions may only be carried out by a qualified contractor.

INSTALLATION

Troubleshooting

Note
When you open the appliance, check the sealing tape. The sealing tape is required for generating the necessary negative pressure.
▶ Replace the sealing tape if required.

Note
The built-in fan must generate a negative pressure of at least 30 Pa.
▶ Check the negative pressure with a barometer on the back of the appliance.

14.1 Resetting the high limit safety cut-out

If the heating water temperature exceeds 75 °C, the electric emergency/booster heater shuts down.

If the electric emergency/booster heater does not switch off, the high limit safety cut-out responds at a heating water temperature of 89 °C.

- ▶ Remove the cause of the fault.

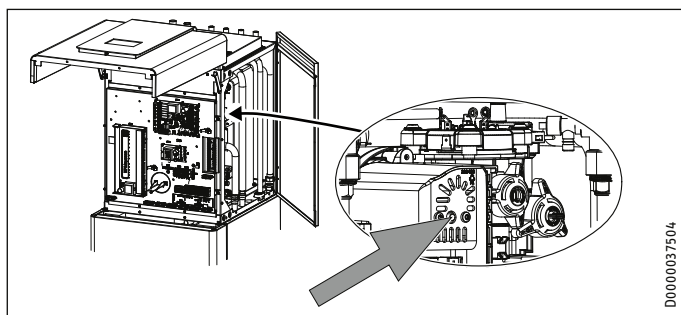

- ▶ Reset the high limit safety cut-out by pressing the reset button. If necessary, use a pointed object to do this.
- ▶ Check whether the heating water is being circulated at a sufficiently high flow rate.

14.2 Resetting the compressor tempering device

If the hot gas temperature exceeds 120 °C, the compressor shuts down.

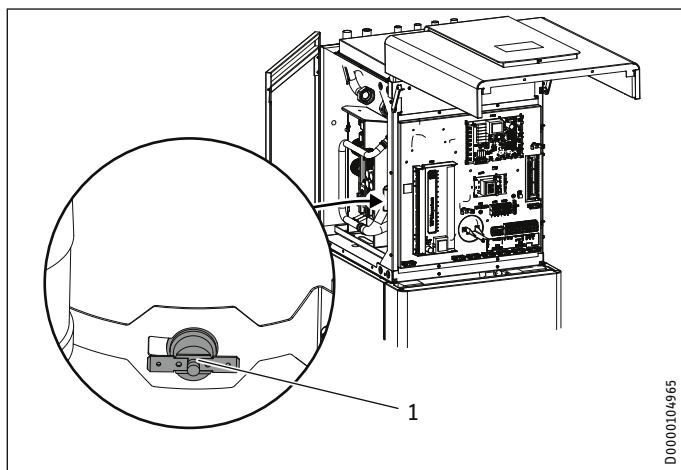

- 1 tempering device reset button
- ▶ Isolate the appliance from the power supply.
- ▶ Remove the cause of the fault.

Note
▶ Do not reset the high limit safety cut-out at temperatures above 65 °C.

- ▶ Reset the high limit safety cut-out by pressing the reset button.

14.3 Checking the IWS DIP switch settings

If the fault cannot be located during a service using the heat pump manager, open the control panel in emergencies and check the IWS settings.

- ▶ Remove the upper panel (see chapter "Installation / Transport / Separating the appliance / Removing the upper front panel").

IWS

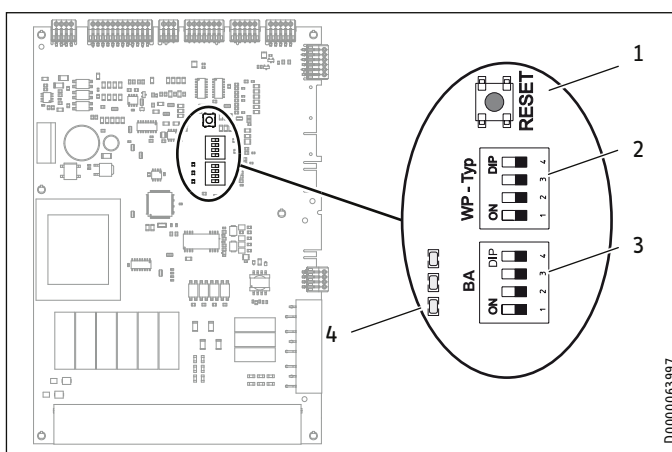

- 1 Reset button
- 2 DIP switch (WP-Typ)
- 3 DIP switch (BA)
- 4 LEDs

DIP switch (WP-Typ)

The DIP switch (WP-Typ) on the IWS serves to set the relevant heat pump type.

Factory setting

Compressor mode with electric emergency/booster heater

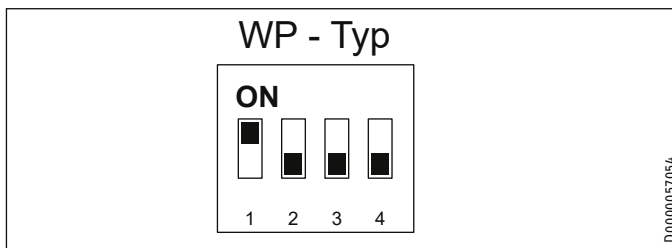

- ▶ Check whether the DIP switch is set correctly.

Compressor mode with an external second heat generator



Material losses

In this case, do not connect the electric emergency/booster heater.

INSTALLATION

Maintenance

If the appliance is operated in dual mode with an external second heat generator, set the DIP switch as follows.

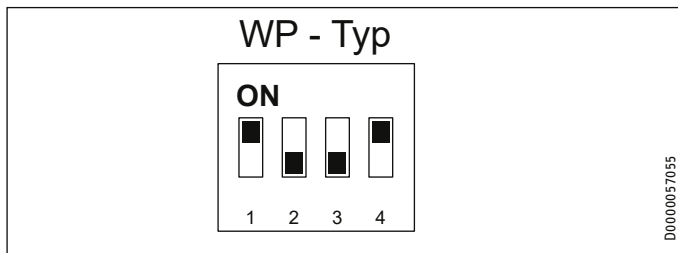

DIP switch (BA)

- ▶ Check whether the DIP switch (BA) is set correctly.

Heating and cooling operation

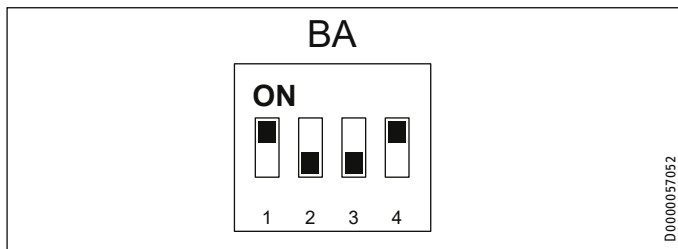

14.4 LEDs (IWS)

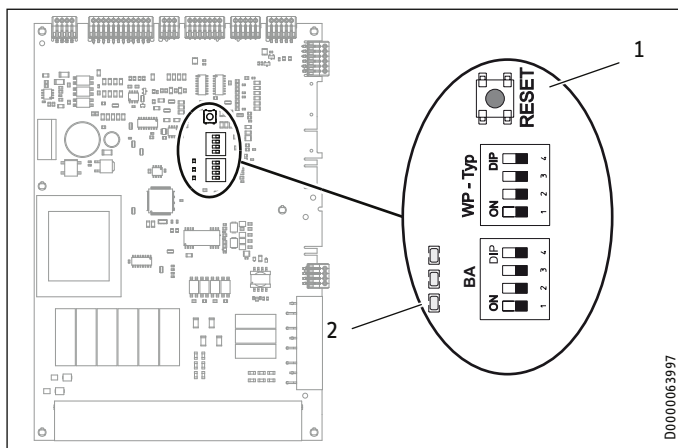

- 1 Reset button
- 2 LEDs

The following table shows the meaning of the LEDs on the IWS.

LED indicator	Meaning
Red LED flashes	Single fault. The appliance shuts down. The appliance restarts after 10 minutes. The LED goes off.
Red LED illuminates	Multiple faults have occurred. The appliance shuts down. The appliance only restarts following a reset on the IWS. This also resets the internal fault counter. The appliance can be restarted after 10 minutes. The LED goes off.
Green LED (centre) flashes	The heat pump is initialising.
Green LED (centre) illuminates	The heat pump was initialised successfully and the connection with the WPM is active.

Faults indicated by the red LED:

- High pressure fault
- Low pressure fault

- Central fault
- Hardware fault on the IWS

14.5 Reset button

If the IWS was incorrectly initialised, you can reset the settings with this button.

- ▶ For this, also observe chapter "Reset options" in the heat pump manager commissioning instructions.

15. Maintenance



WARNING Electrocutation

- ▶ Prior to commencing any service or cleaning work, isolate the appliance across all poles from the power supply.

Following disconnection from the power supply, parts of the appliance may remain energised for 5 minutes until the inverter capacitors have discharged.



Note

When you open the appliance, check the sealing tape. The sealing tape is required for generating the necessary negative pressure.

- ▶ Replace the sealing tape if required.

We recommend a regular inspection (to establish the current condition of the system), and maintenance if required (to return the system to its original condition).

- ▶ Check the discharge aperture on the top of the appliance and the intake aperture on the side of the appliance (visual check). Remove any contaminants and blockages immediately.

15.1 DHW cylinders

Opening the appliance

- ▶ Remove the upper and lower front panels (see chapter "Installation / Transport / Opening the appliance").

Draining the DHW cylinder



WARNING Burns

Hot water may escape when draining the DHW cylinder.

- ▶ Close the shut-off valve in the cold water inlet line.
- ▶ Open the hot water taps on all draw-off points.

INSTALLATION Specification

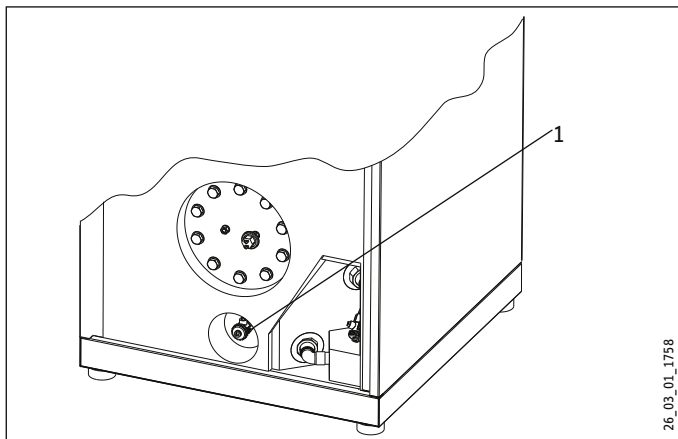

1 Drain

► Empty the DHW cylinder via the drain.

Please note that some residual water will remain in the bottom of the cylinder.

Cleaning and descaling

- Remove the flange plate.
- Clean the DHW cylinder through the inspection port.
- Never use descaling pumps. Never use descaling agents to clean the enamel coating and protective anodes.

Replacing the protective anodes

Two protective anodes are installed in the DHW cylinder to protect it against corrosion. One of the protective anodes has a consumption indicator.

- Check the protective anodes at regular intervals.

We recommend checking the protective anodes at the latest two years after commissioning.



Material losses

Replace the protective anodes when the colour of the protective anode with the consumption indicator changes from white to red.

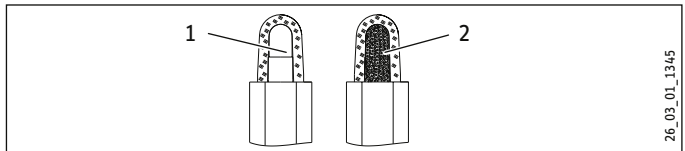

- 1 white = protective anode OK
- 2 red = replace protective anodes

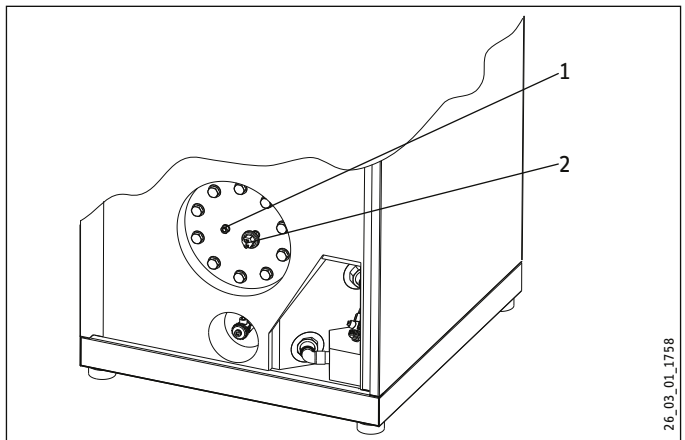

- 1 Protective anode without consumption indicator
- 2 Protective anode with consumption indicator



Material losses

Install the protective anodes as shown in the diagram.

16. Specification

16.1 Dimensions and connections

			HPG-I 04 DS Premium	HPG-I 06 DS Premium	HPG-I 08 DS Premium	HPG-I 12 DS Premium	HPG-I 15 DS Premium
b01	Entry electrical cables						
c01	Cold water inlet	Diameter	mm	22	22	22	22
c06	DHW outlet	Diameter	mm	22	22	22	22
c10	DHW circulation						
c12	Safety valve drain	Diameter	mm	22	22	22	22
e01	Heating flow	Diameter	mm	22	22	22	22
e02	Heating return	Diameter	mm	22	22	22	22
f01	Heat source flow	Diameter	mm	28	28	28	28
f02	Heat source return	Diameter	mm	28	28	28	28

INSTALLATION Specification

			HPG-I 04 DCS Premium	HPG-I 06 DCS Premium	HPG-I 08 DCS Premium	HPG-I 12 DCS Premium	HPG-I 15 DCS Premium
b01	Entry electrical cables						
c01	Cold water inlet	Diameter mm	22	22	22	22	22
c06	DHW outlet	Diameter mm	22	22	22	22	22
c10	DHW circulation						
c12	Safety valve drain	Diameter mm	22	22	22	22	22
e01	Heating flow	Diameter mm	22	22	22	22	22
e02	Heating return	Diameter mm	22	22	22	22	22
f01	Heat source flow	Diameter mm	28	28	28	28	28
f02	Heat source return	Diameter mm	28	28	28	28	28

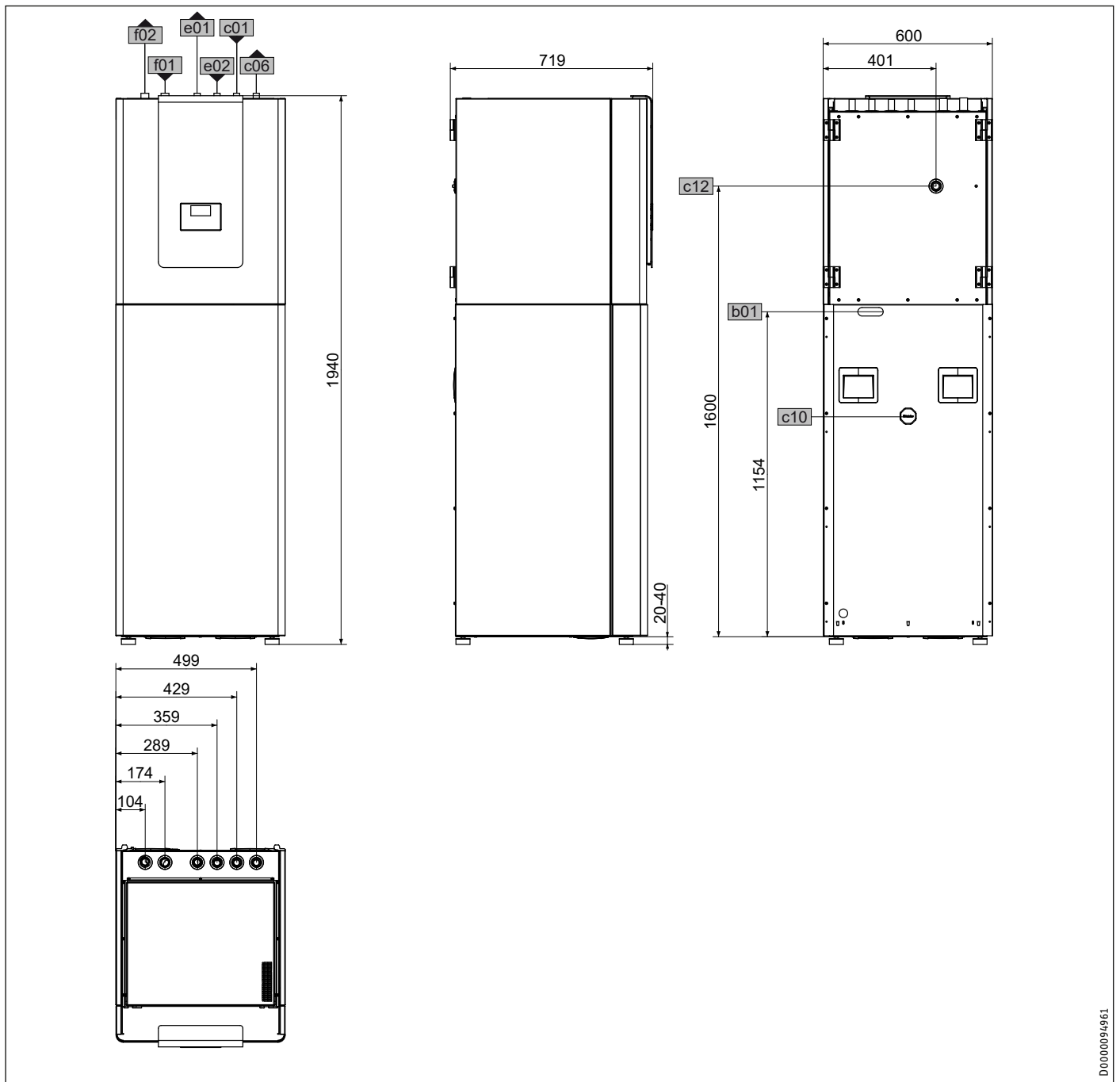

D0000054961

INSTALLATION Specification

16.2 Wiring diagram

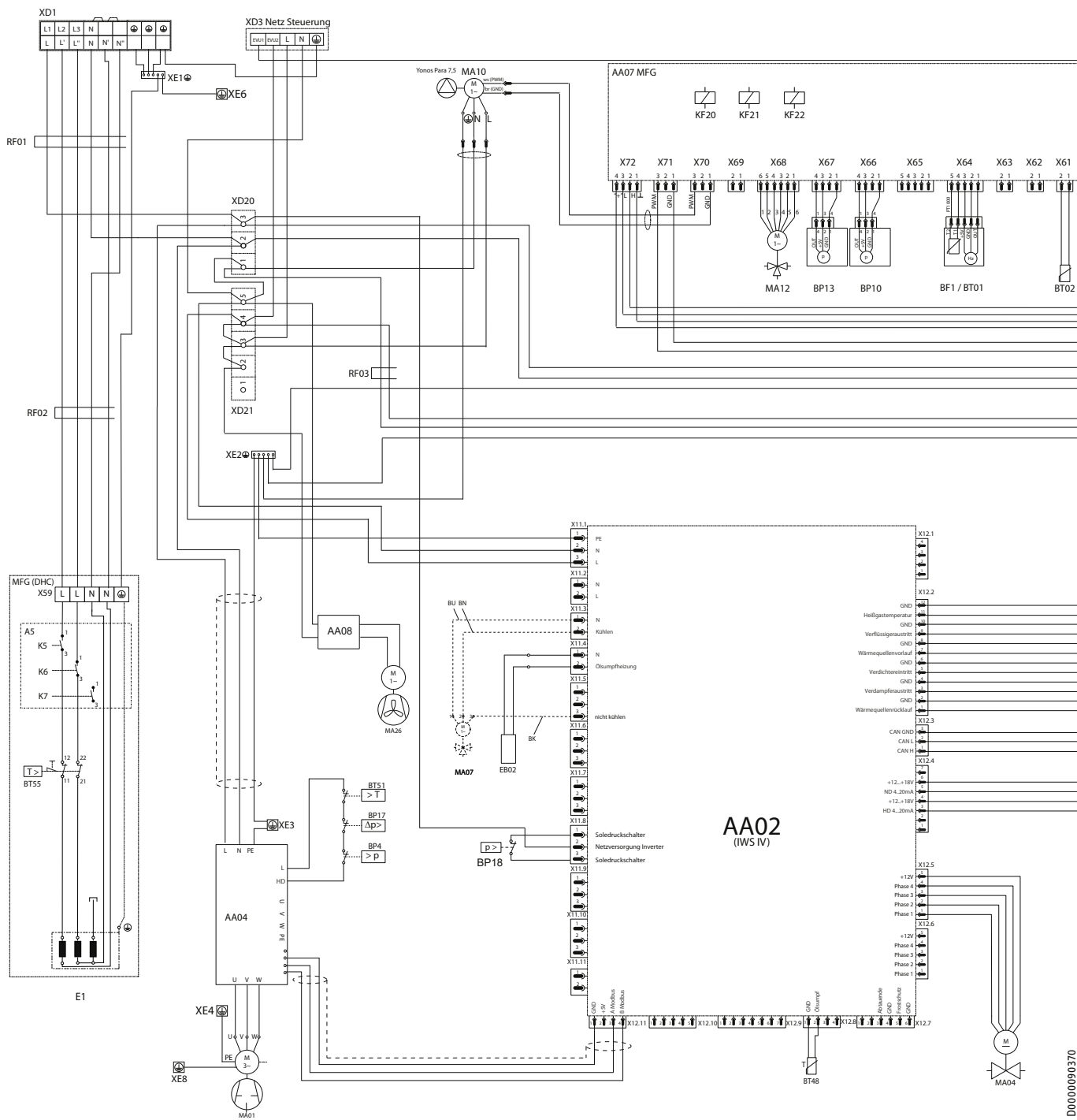

D0000090370

INSTALLATION Specification

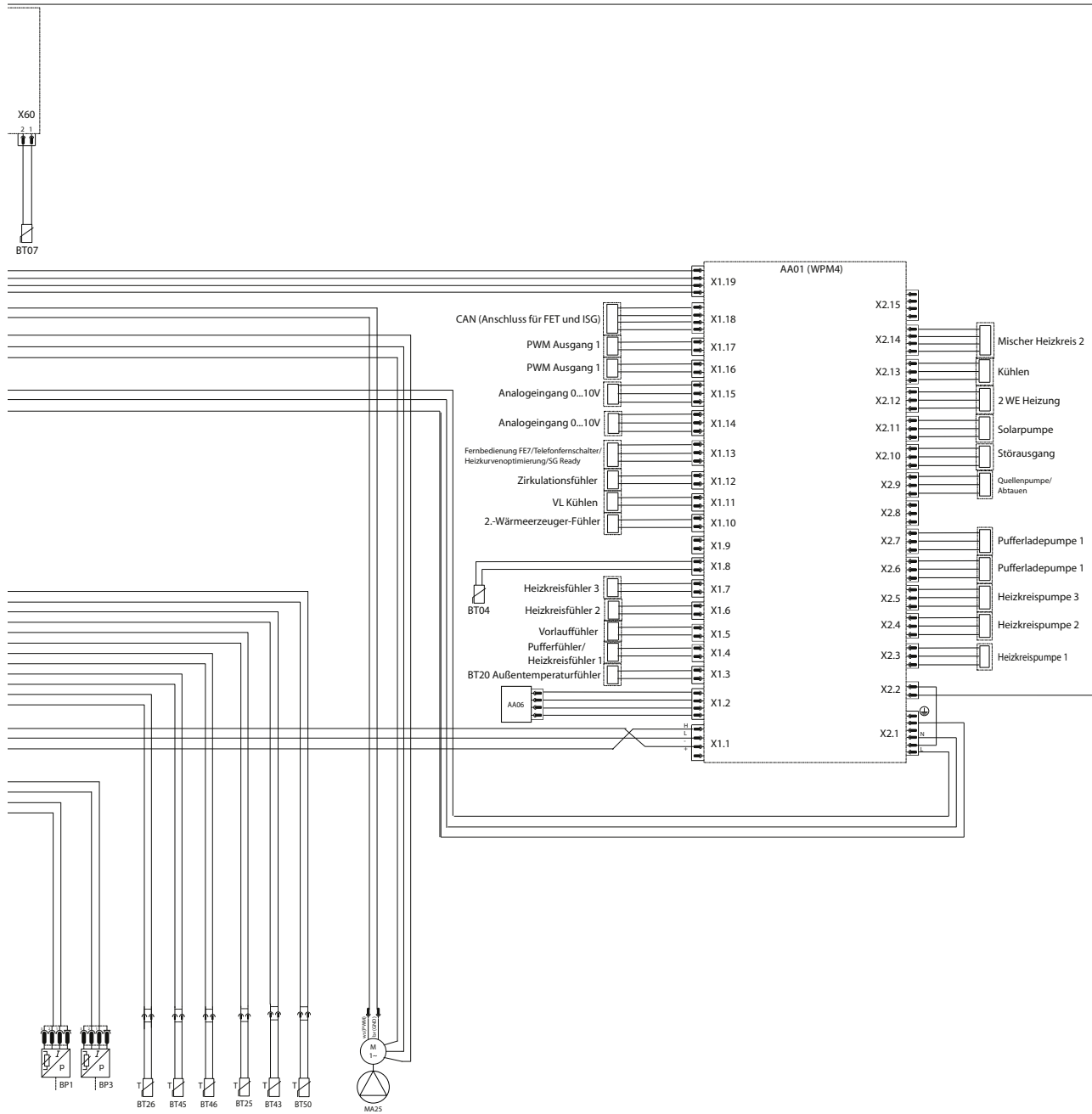

D0000090370

INSTALLATION

Specification

Key	
AA01	Heat pump manager (WPM)
AA02	Integral heat pump control unit (IWS)
AA04	Inverter compressor
AA06	Programming unit
AA07	Multifunction assembly MFG 3.2
AA08	Fan power supply unit
BF1	Flow sensor, heating
BL01	Float switch
BP1	High pressure sensor (34 bar)
BP3	Low pressure sensor (16 bar)
BP4	High pressure switch (34 bar)
BP10	Heating circuit pressure sensor
BP13	Heat source pressure sensor
BP17	Internal negative pressure barometric cell
BP18	Heat source pressure switch
BT01	Heating flow temperature sensor - Pt1000
BT02	Heating return temperature sensor - Pt1000
BT07	Heating flow temperature sensor, multifunction assembly MFG - Pt1000
BT20	Outdoor air temperature sensor - Pt1000
BT25	Heat source flow temperature sensor - Pt1000
BT26	Heat source return temperature sensor - Pt1000
BT43	Condenser outlet temperature sensor - Pt1000
BT45	Temperature sensor, evaporator discharge
BT46	Compressor intake temperature sensor - Pt1000
BT48	Oil sump temperature sensor - Pt1000
BT50	Hot gas temperature sensor - Pt1000
BT51	Temperature switch, compressor housing
BT55	High limit safety cut-out MFG
EB02	Oil sump heater
KF06	Contacteur
KF20	Emergency/booster heater relay, multifunction assembly MFG
KF21	Emergency/booster heater relay, multifunction assembly MFG
KF22	Emergency/booster heater relay, multifunction assembly MFG
MA01	Compressor motor
MA04	Electrical expansion valve stepper motor
MA07	Heating/cooling diverter valve motor
MA10	Circulation pump
MA12	DHW heating diverter valve motor
MA25	Heat source pump motor
MA26	Suction fan
RF01	Snap-on ferrite bead, compressor cable, emergency/booster heater cable
RF02	Snap-on ferrite bead, emergency/booster heater cable
RF03	Snap-on ferrite bead, WPM cable
XD1	Terminal, external emergency/booster heater, HP power supply
XD3	External control terminal
XD20	Distribution terminal
XD21	Distribution terminal
XE1	Earth block
XE2	Earth block
XE3	Earth stud, inverter panel
XE4	Earth stud, inverter cooling
XE6	Earth stud, programming unit panel
XE8	Earth stud, oscillation plate
X1.1	WPM CAN IWS
X1.2	WPM CAN programming unit
X1.3	WPM outside temperature sensor
X1.4	WPM buffer cylinder / HC 1
X1.6	WPM HC 2
X1.8	WPM DHW sensor
X1.10	WPM 2nd heat generator sensor
X1.11	WPM flow, cooling
X1.12	WPM DHW, bottom
X1.14	WPM analogue input 0-10 V
X1.15	WPM analogue input 0-10 V
X1.16	WPM solar circuit pump PWM
X1.17	WPM 2nd heat generator PWM
X1.19	WPM CAN MFG
X2.1	WPM power supply
X2.2	WPM power-OFF
X2.3	WPM HC pump 1
X2.4	WPM mixer pump 1 / HC pump 2
X2.10	WPM fault output
X2.11	WPM solar circuit pump
X2.14	WPM mixer 1
X11.1	3-pin IWS plug - power supply control
X11.3	2-pin IWS plug - defrost valve
X11.4	2-pin IWS plug - oil sump heater
X11.8	3-pin IWS plug - power-OFF
X12.1	4-pin IWS Rast plug - fan PWM
X12.2	12-pin IWS Rast plug - temperature sensor 1
X12.3	3-pin IWS Rast plug - BUS connection
X12.4	7-pin IWS Rast plug - high/low pressure
X12.5	5-pin IWS Rast plug - expansion valve
X12.6	5-pin IWS Rast plug - inverter cooling valve
X12.7	6-pin IWS Rast plug - temperature sensor 2
X12.9	7-pin IWS Rast plug - air differential pressure sensor
X12.11	4-pin IWS Rast plug - Modbus inverter

16.3 Output diagrams

16.3.1 HPG-I 04 DS Premium | HPG-I 04 DCS Premium

Heating output

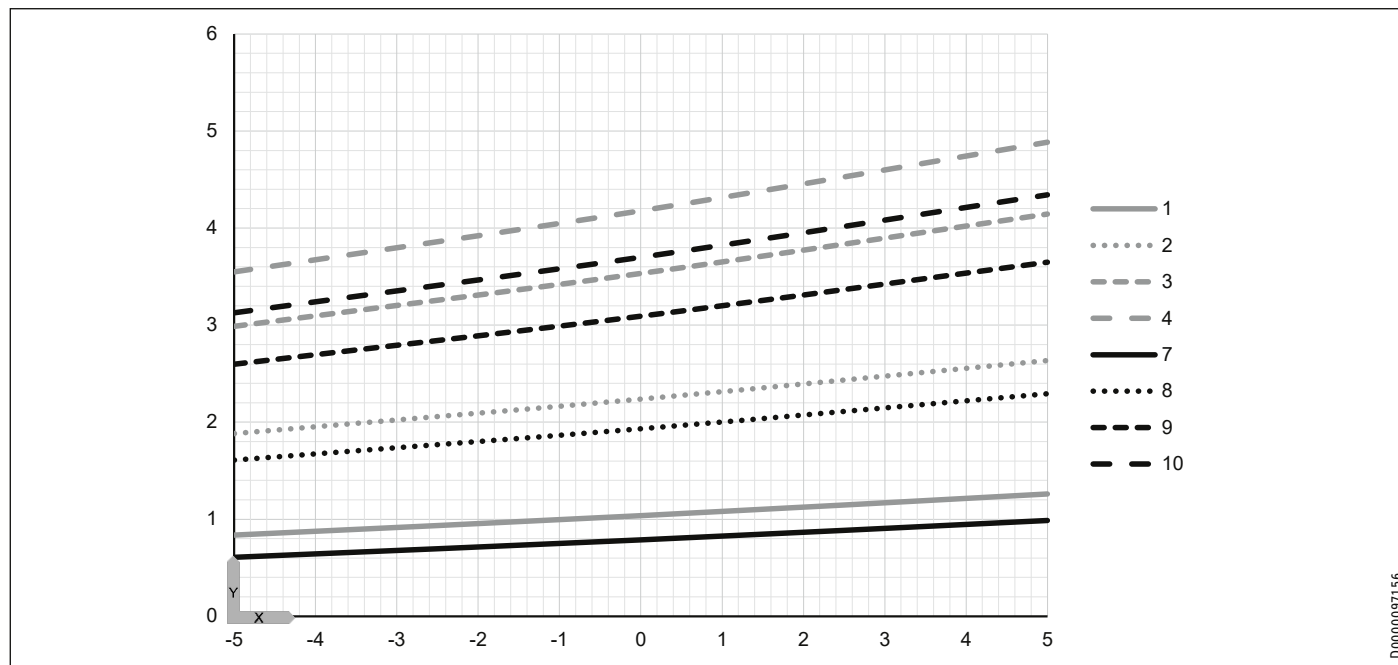

D0000097156

	X Inlet temperature of the WQA medium [°C]	Y Heating output [kW]
Flow temperature	35 °C	55 °C
Output [Hz]	1 Min. 2 40 3 60 4 80	7 Min. 8 40 9 60 10 80

Power consumption

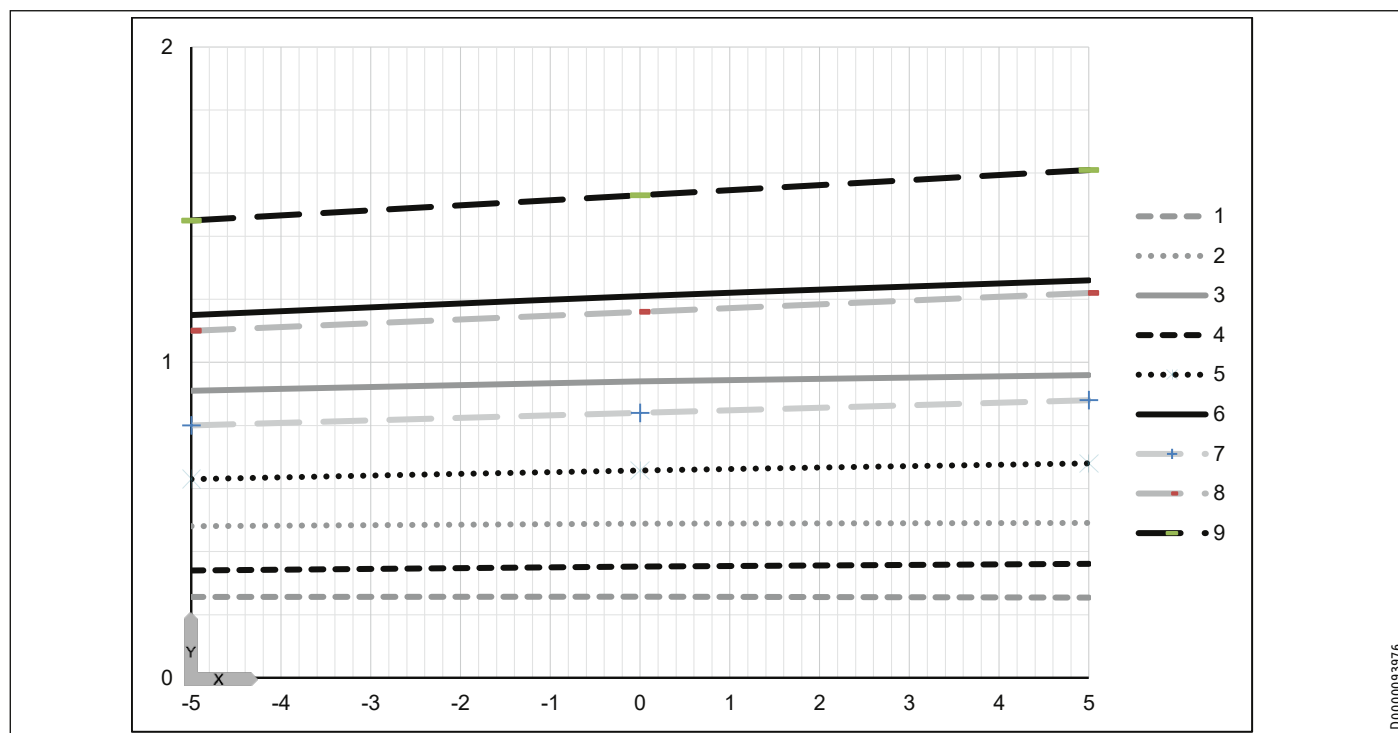

D0000093976

	X Inlet temperature of the WQA medium [°C]	Y Power consumption [kW]
Flow temperature	35 °C	55 °C
Output	1 1 % 2 50 % 3 100 %	4 1 % 5 50 % 6 100 %

INSTALLATION Specification

Coefficient of performance

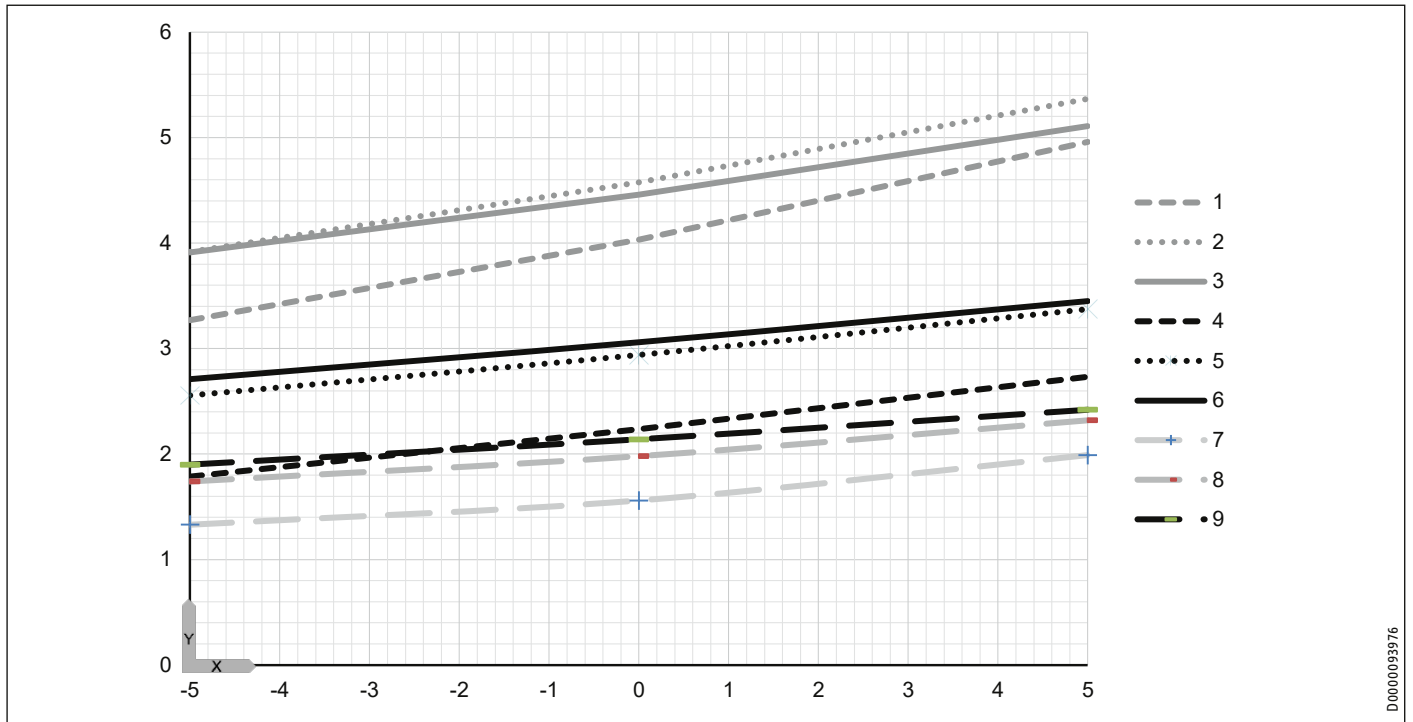

	X Inlet temperature of the WQA medium [°C]	Y Coefficient of performance e [-]
Flow temperature	35 °C	55 °C
Output	1 1 % 2 50 % 3 100 %	4 1 % 5 50 % 6 100 %

Cooling capacity

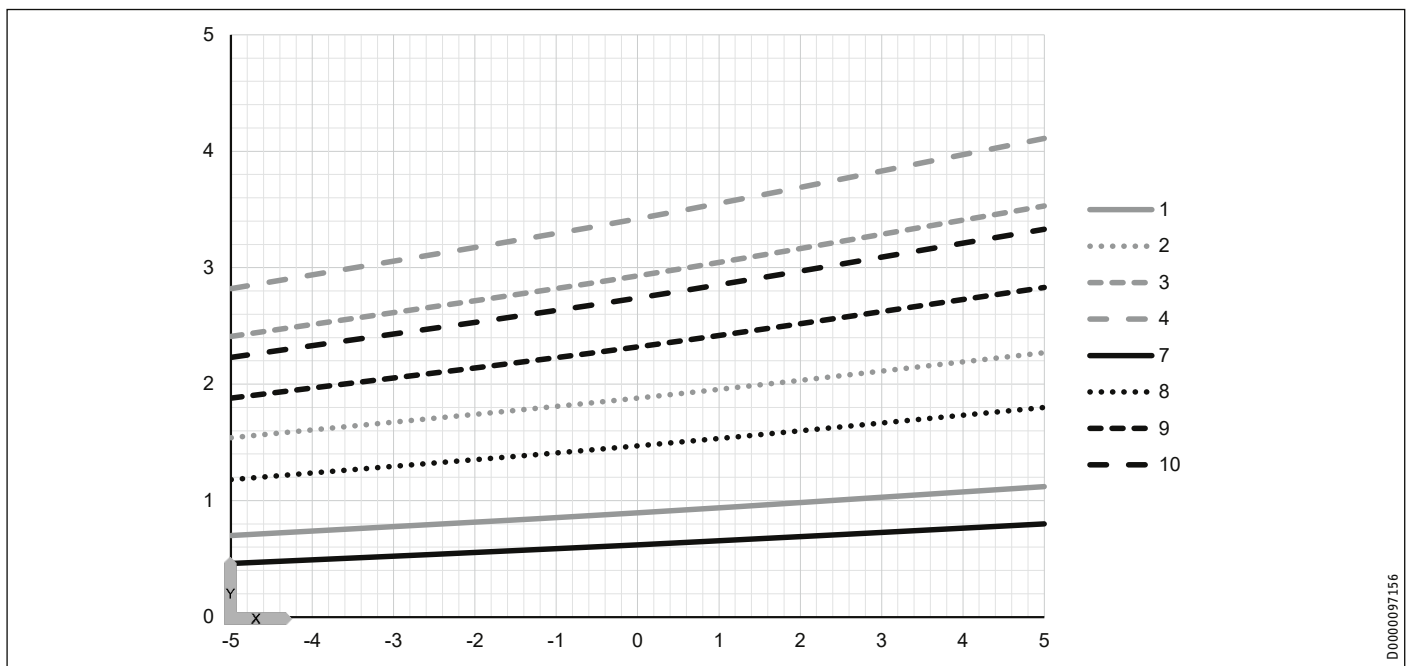

	X Inlet temperature of the WQA medium [°C]	Y Cooling capacity [kW]
Flow temperature	35 °C	55 °C
Output [Hz]	1 Min. 2 40 3 60 4 80	7 Min. 8 40 9 60 10 80

INSTALLATION Specification

16.3.2 HPG-I 06 DS Premium | HPG-I 06 DCS Premium

Heating output

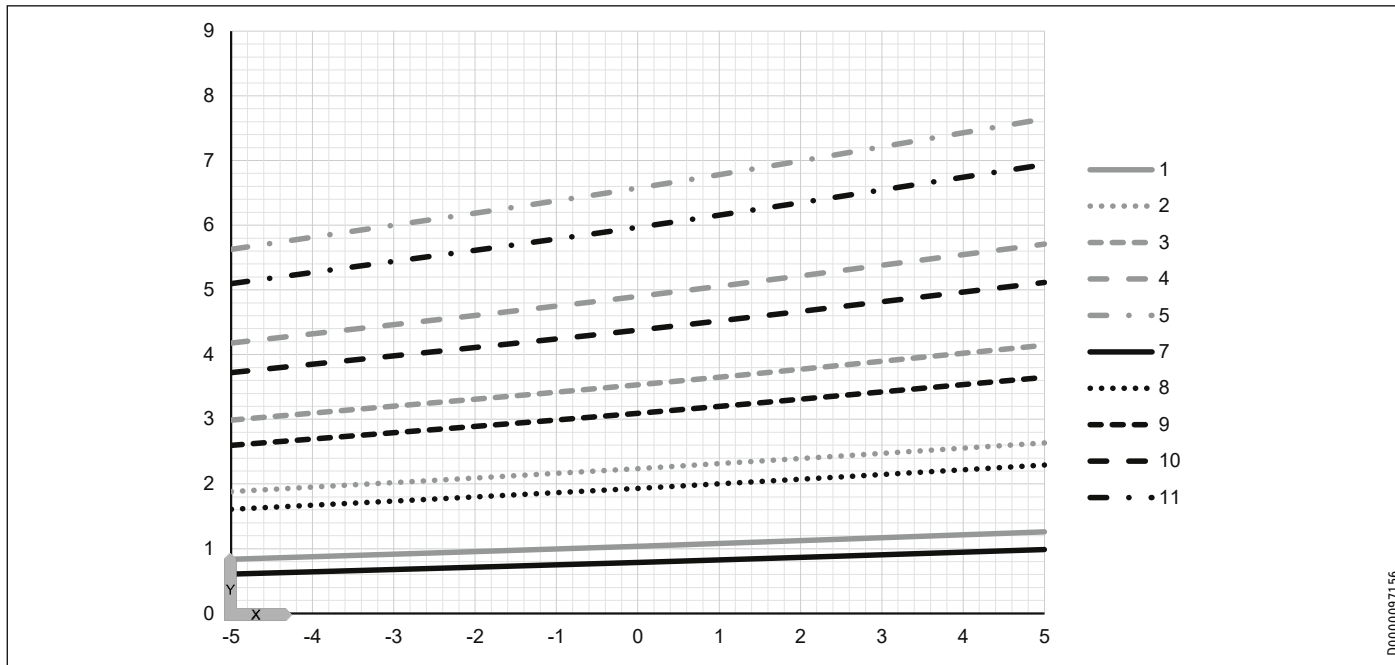

D0000097156

	X Inlet temperature of the WQA medium [°C]	Y Heating output [kW]
Flow temperature	35 °C	55 °C
Output [Hz]	1 Min. 2 40 3 60 4 80 5 100	7 Min. 8 40 9 60 10 80 11 100

Power consumption

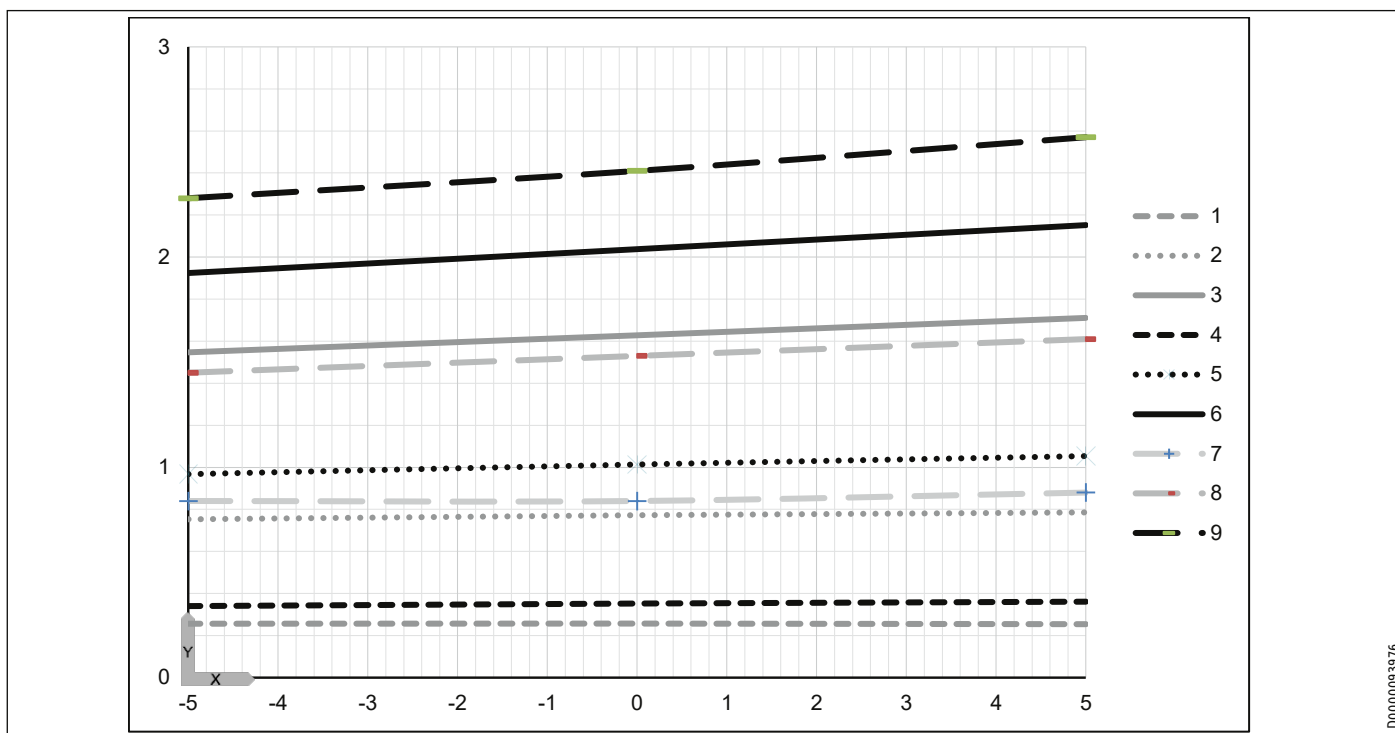

D0000093976

	X Inlet temperature of the WQA medium [°C]	Y Power consumption [kW]
Flow temperature	35 °C	55 °C
Output	1 1 % 2 50 % 3 100 %	4 1 % 5 50 % 6 100 %

INSTALLATION Specification

Coefficient of performance

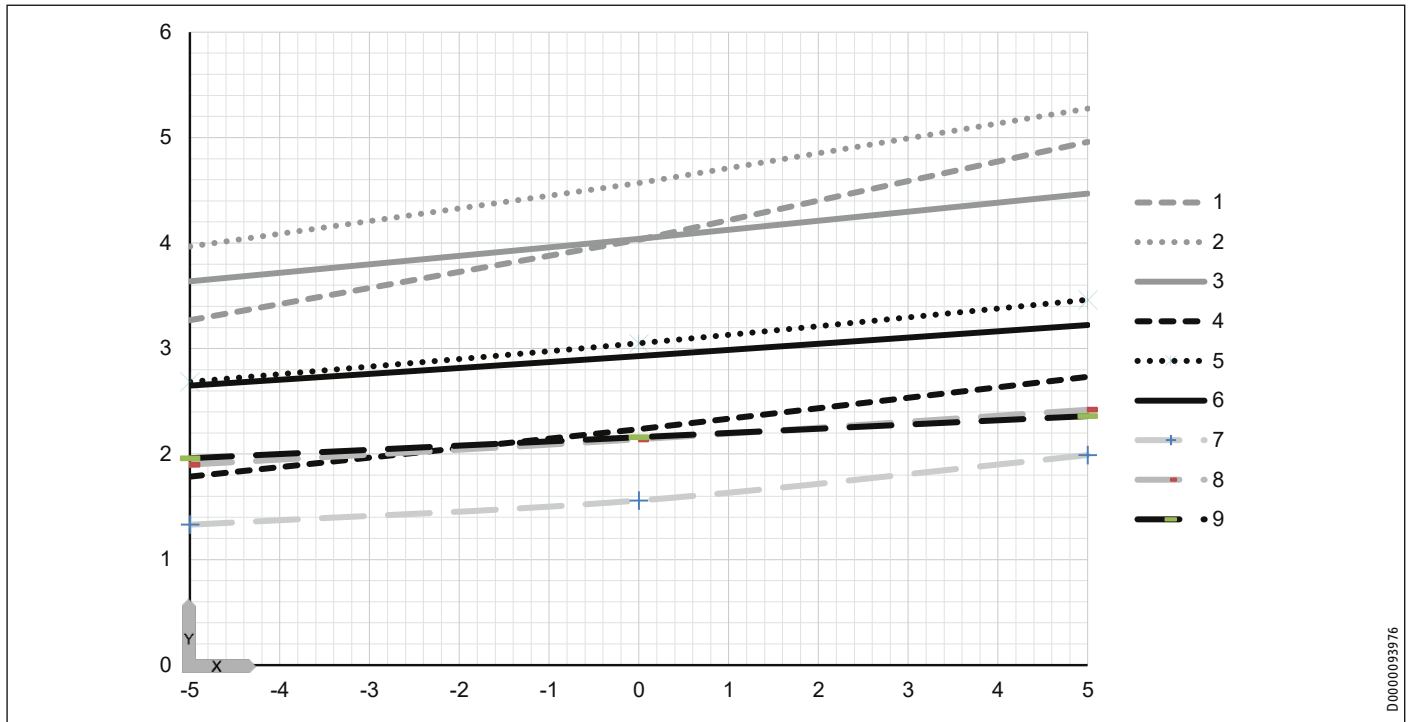

	X Inlet temperature of the WQA medium [°C]			Y Coefficient of performance e [-]		
Flow temperature	35 °C			55 °C		
Output	1 1 %	2 50 %	3 100 %	4 1 %	5 50 %	6 100 %

Cooling capacity

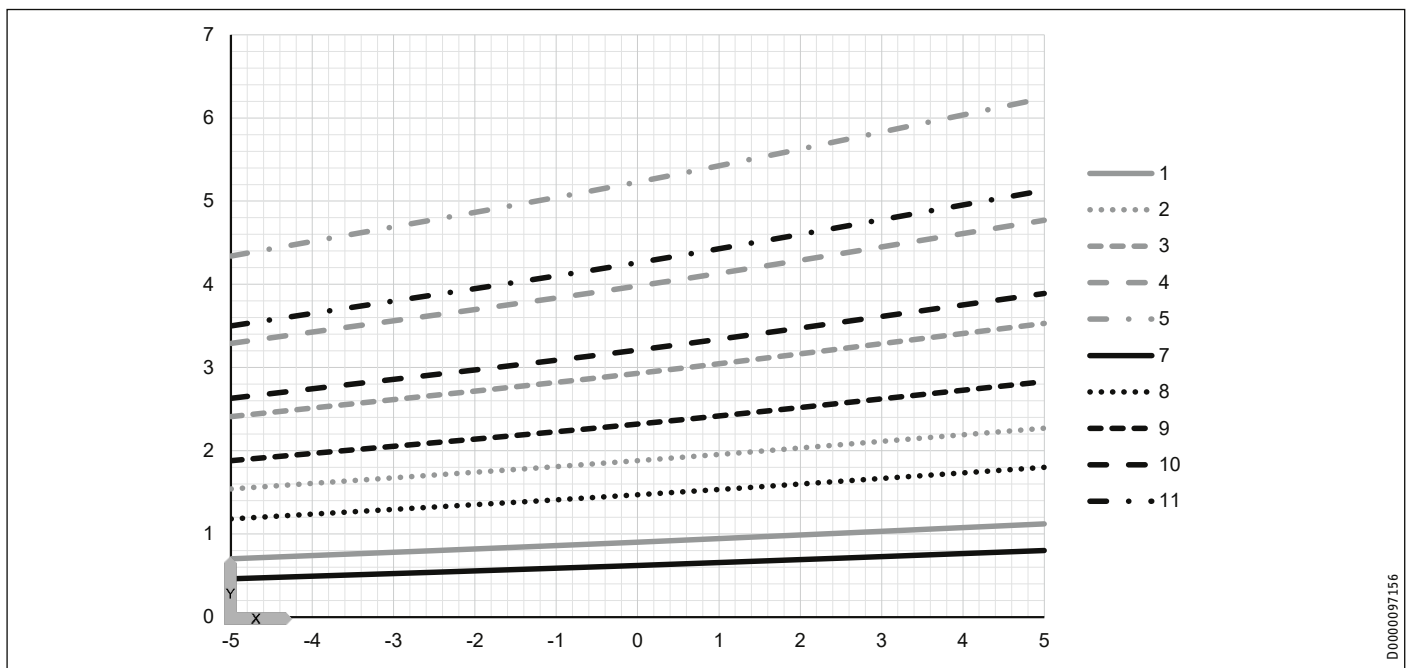

	X Inlet temperature of the WQA medium [°C]					Y Cooling capacity [kW]				
Flow temperature	35 °C					55 °C				
Output [Hz]	1 Min.	2 40	3 60	4 80	5 100	7 Min.	8 40	9 60	10 80	11 100

INSTALLATION Specification

16.3.3 HPG-I 08 DS Premium | HPG-I 08 DCS Premium

Heating output

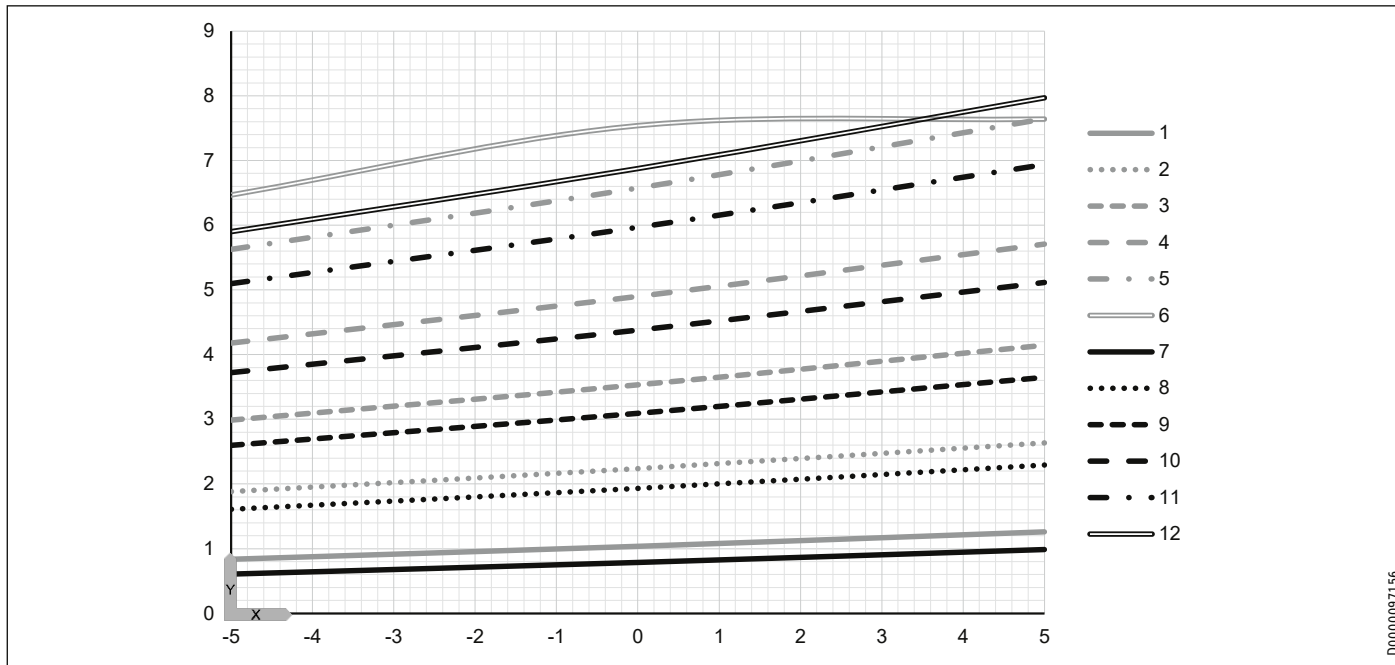

D0000097156

	X Inlet temperature of the WQA medium [°C]	Y Heating output [kW]
Flow temperature	35 °C	55 °C
Output [Hz]	1 Min. 2 40 3 60 4 80 5 100 6 Max. 7 Min. 8 40 9 60 10 80 11 100 12 Max.	

Power consumption

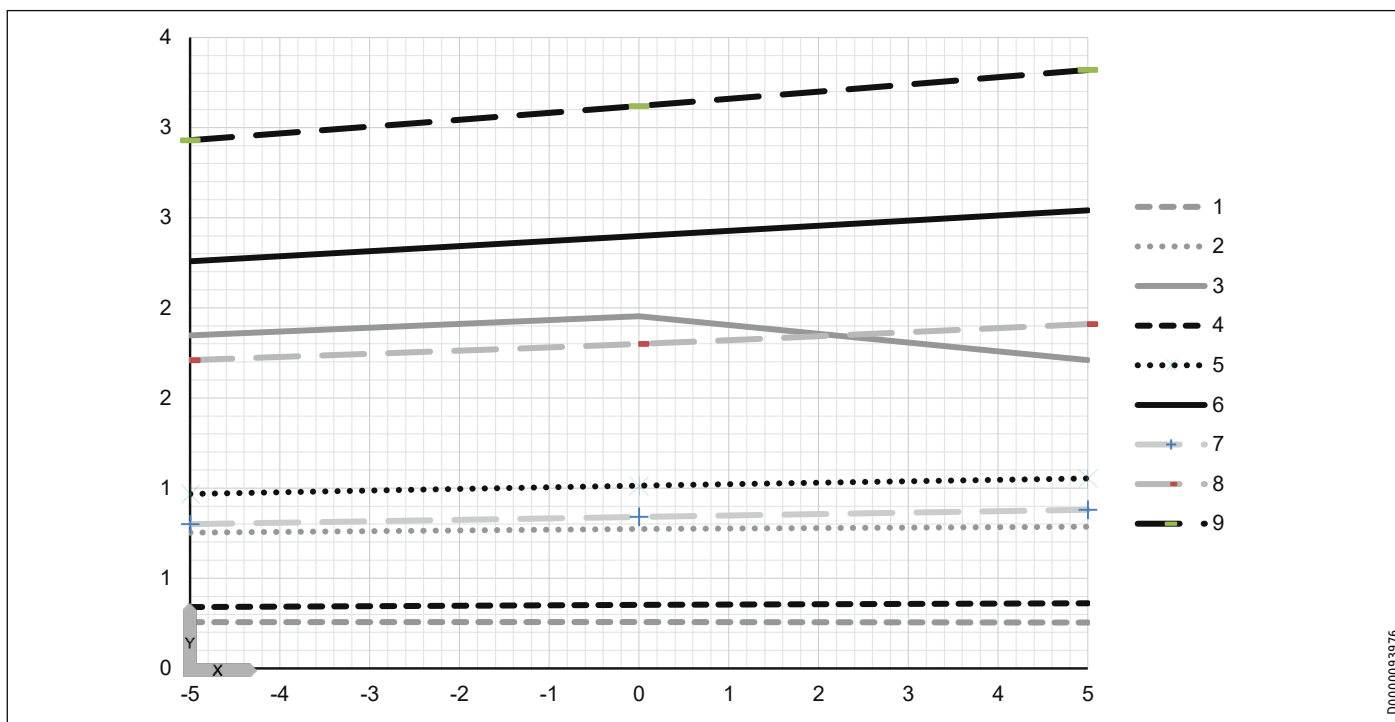

D0000093976

	X Inlet temperature of the WQA medium [°C]	Y Power consumption [kW]
Flow temperature	35 °C	55 °C
Output	1 1 % 2 50 % 3 100 % 4 1 % 5 50 % 6 100 %	

INSTALLATION Specification

Coefficient of performance

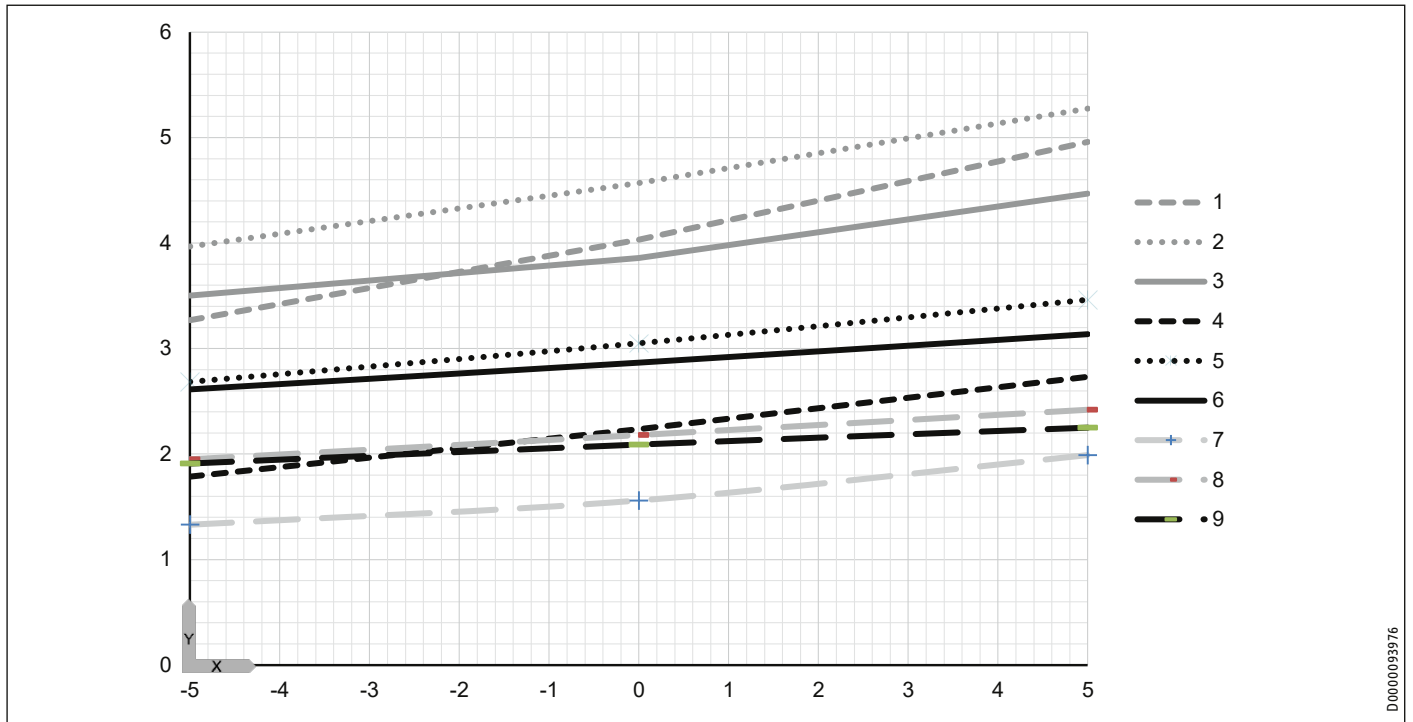

	X Inlet temperature of the WQA medium [°C]	Y Coefficient of performance e [-]
Flow temperature	35 °C	55 °C
Output	1 1% 2 50% 3 100%	4 1% 5 50% 6 100%

Cooling capacity

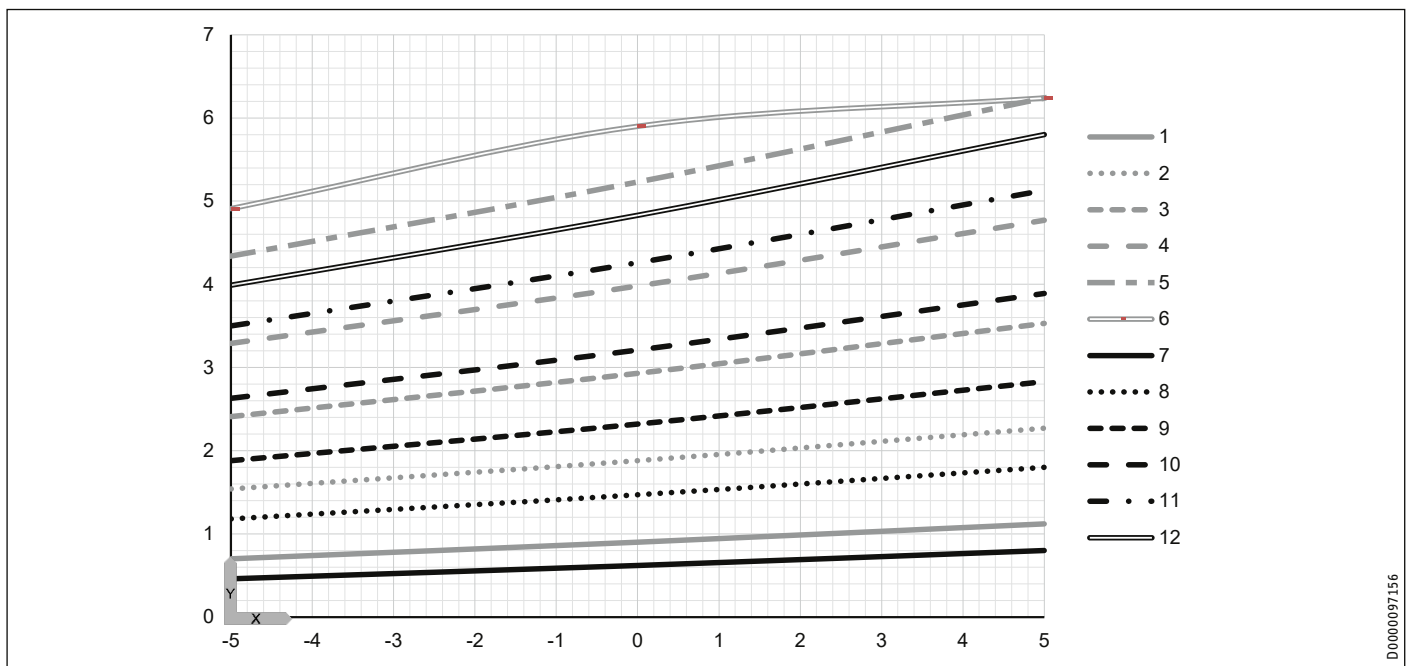

	X Inlet temperature of the WQA medium [°C]	Y Cooling capacity [kW]
Flow temperature	35 °C	55 °C
Output [Hz]	1 Min. 2 40 3 60 4 80 5 100 6 Max.	7 Min. 8 40 9 60 10 80 11 100 12 Max.

INSTALLATION Specification

16.3.4 HPG-I 12 DS Premium | HPG-I 12 DCS Premium

Heating output

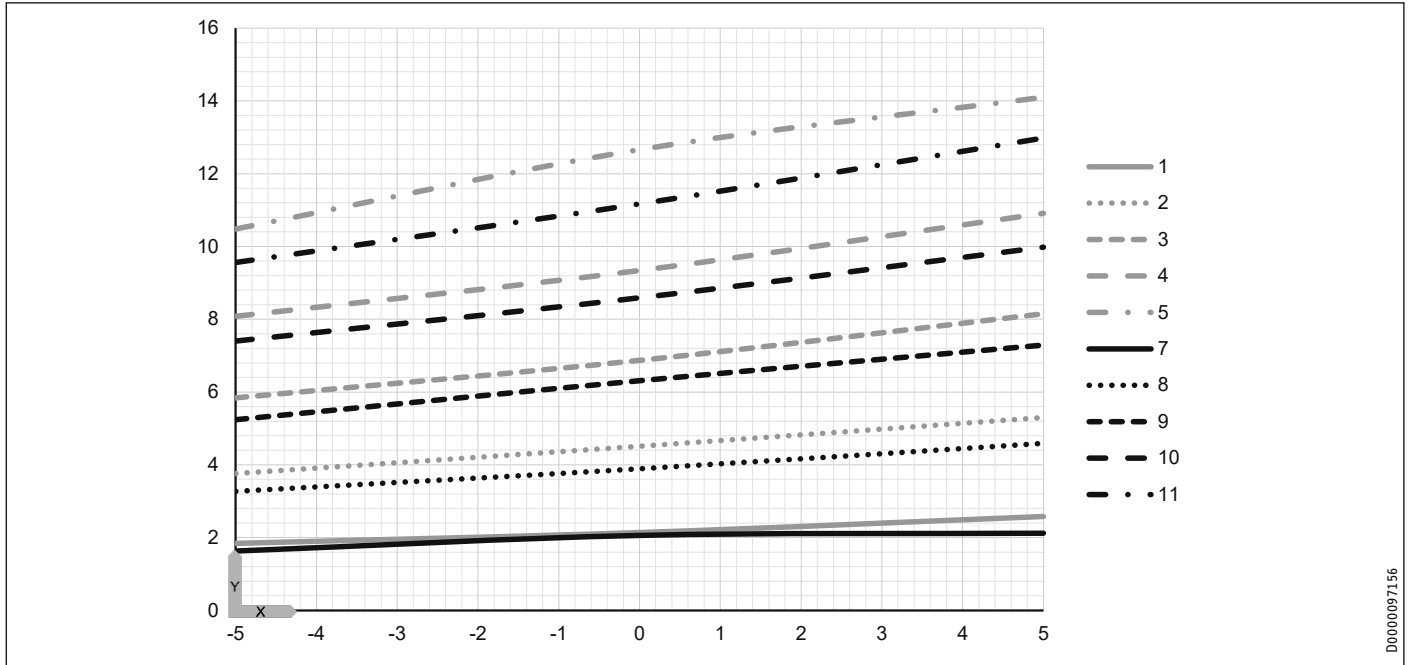

D0000097156

	X Inlet temperature of the WQA medium [°C]	Y Heating output [kW]
Flow temperature	35 °C	55 °C
Output [Hz]	1 Min. 2 40 3 60 4 80 5 100	7 Min. 8 40 9 60 10 80 11 100

Power consumption

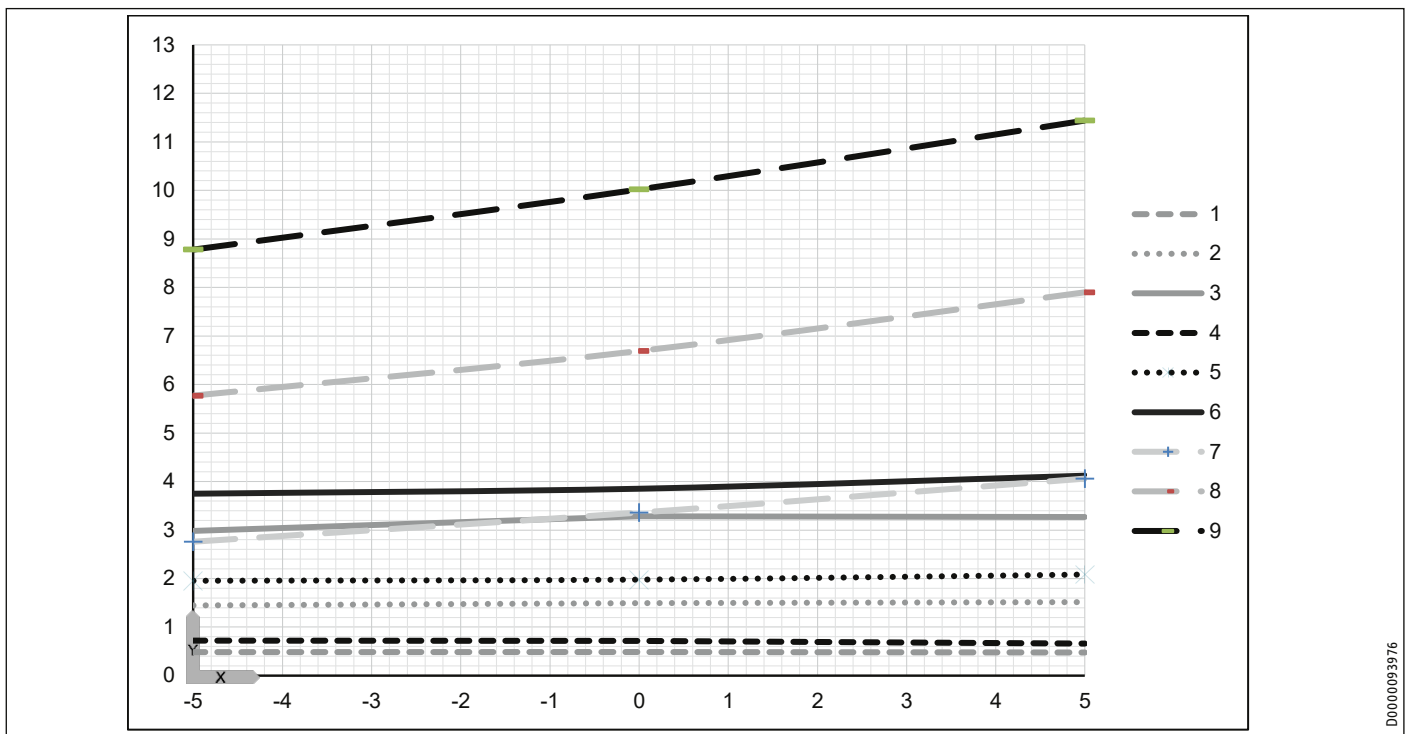

D0000093976

	X Inlet temperature of the WQA medium [°C]	Y Power consumption [kW]
Flow temperature	35 °C	55 °C
Output	1 1 % 2 50 % 3 100 %	4 1 % 5 50 % 6 100 %

INSTALLATION Specification

Coefficient of performance

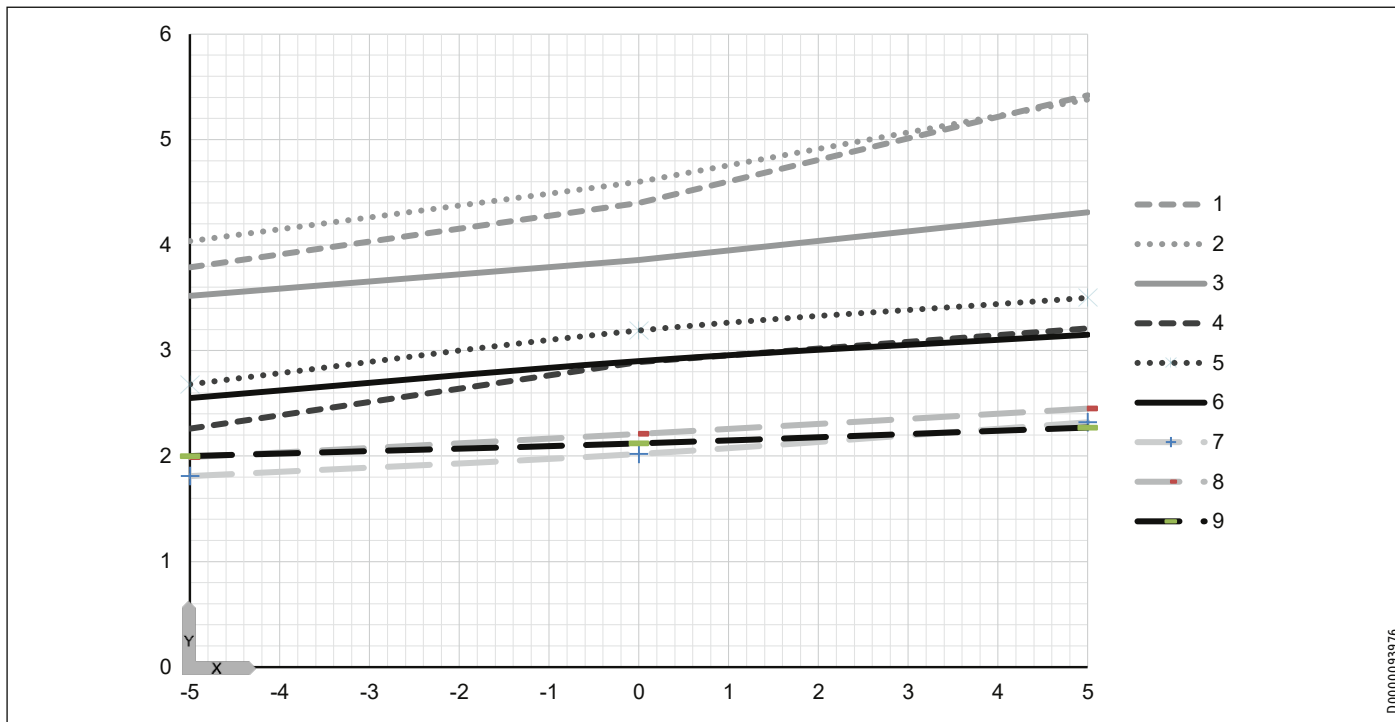

	X Inlet temperature of the WQA medium [°C]	Y Coefficient of performance e [-]
Flow temperature	35 °C	55 °C
Output	1 1 % 2 50 % 3 100 %	4 1 % 5 50 % 6 100 %

Cooling capacity

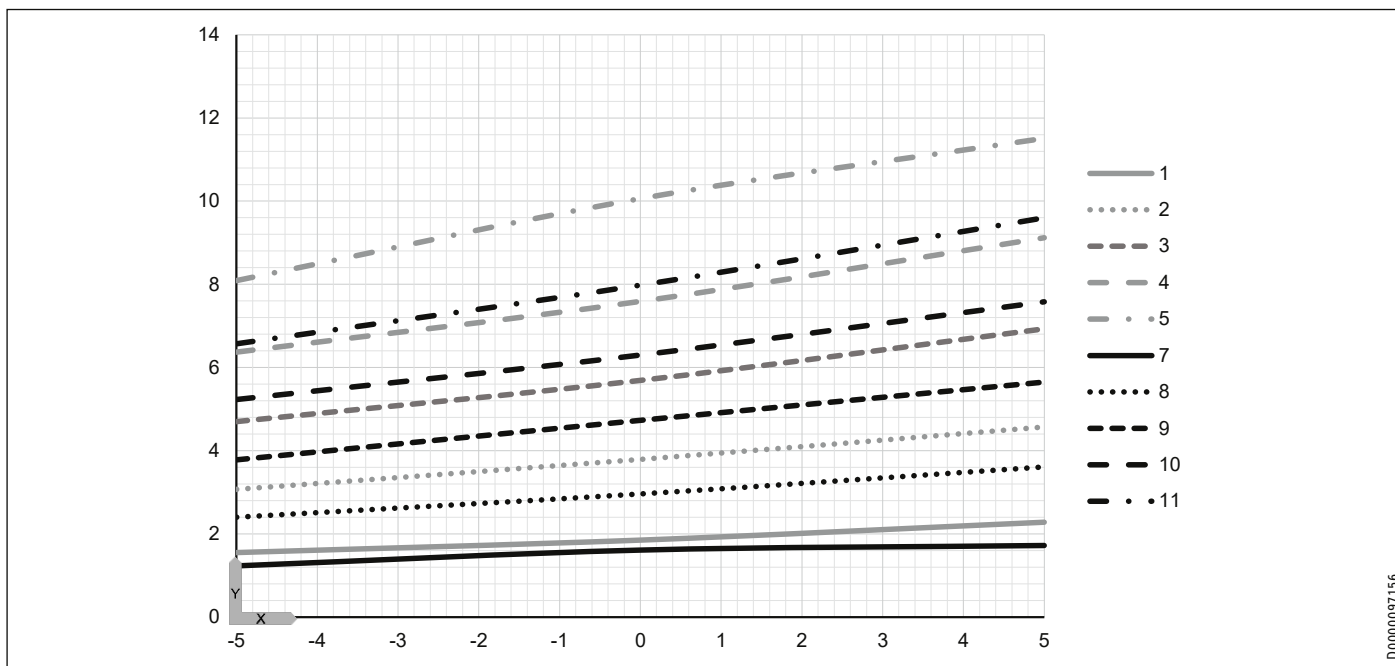

	X Inlet temperature of the WQA medium [°C]	Y Cooling capacity [kW]
Flow temperature	35 °C	55 °C
Output [Hz]	1 Min. 2 40 3 60 4 80 5 100	7 Min. 8 40 9 60 10 80 11 100

INSTALLATION Specification

16.3.5 HPG-I 15 DS Premium | HPG-I 15 DCS Premium

Heating output

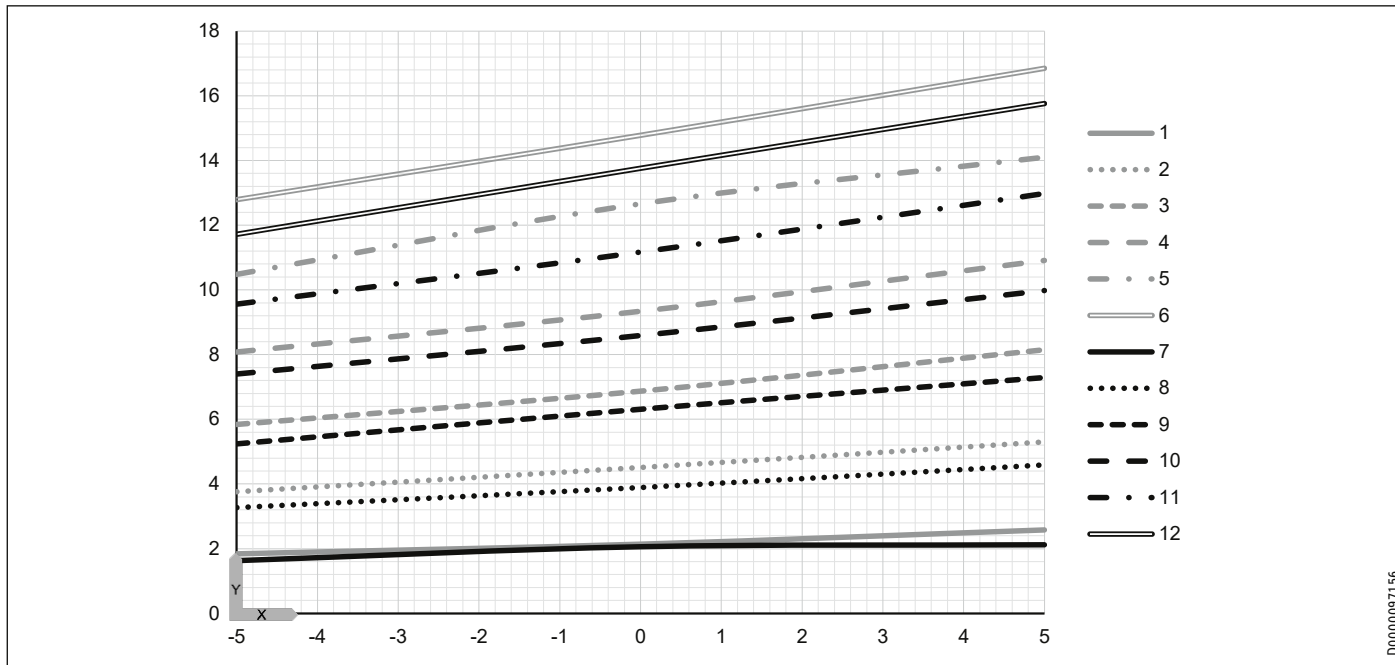

D0000097156

	X Inlet temperature of the WQA medium [°C]	Y Heating output [kW]
Flow temperature	35 °C	55 °C
Output [Hz]	1 Min. 2 40 3 60 4 80 5 100 6 Max. 7 Min. 8 40 9 60 10 80 11 100 12 Max.	

Power consumption

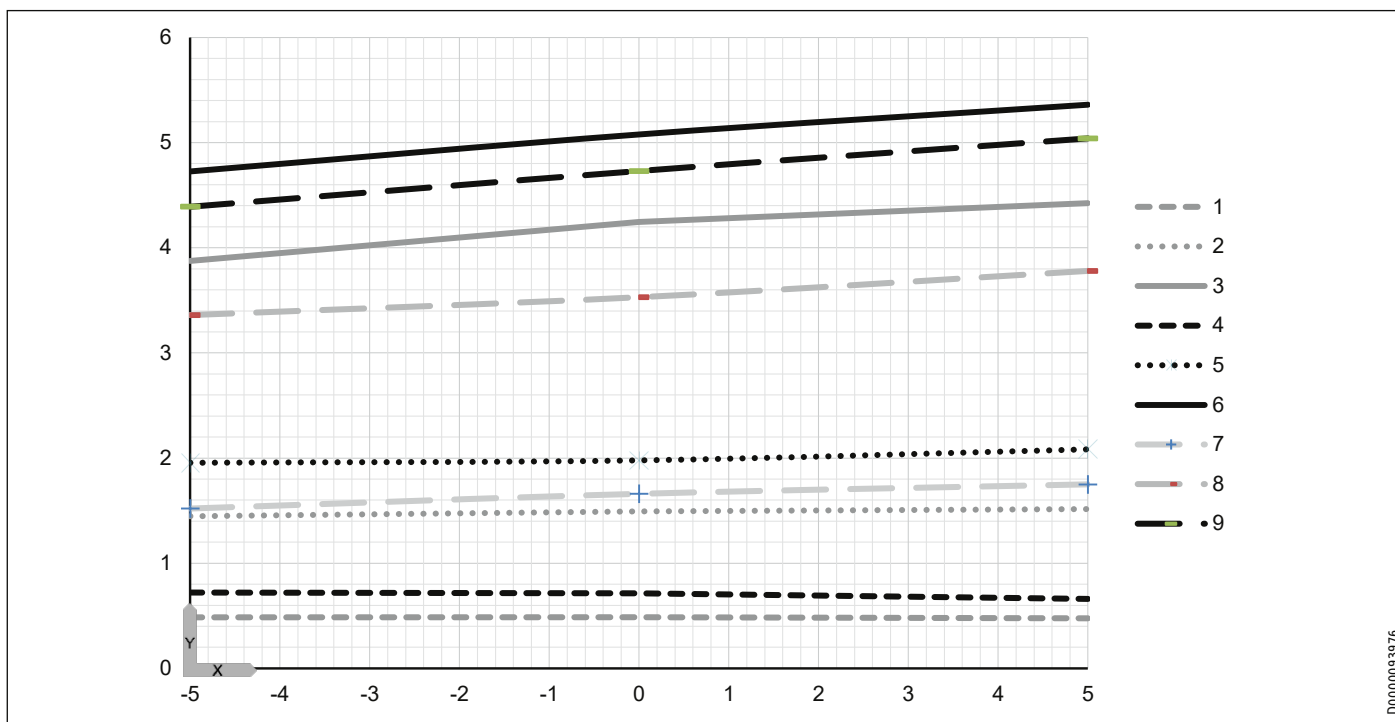

D0000093976

	X Inlet temperature of the WQA medium [°C]	Y Power consumption [kW]
Flow temperature	35 °C	55 °C
Output	1 1 % 2 50 % 3 100 % 4 1 % 5 50 % 6 100 %	

INSTALLATION Specification

Coefficient of performance

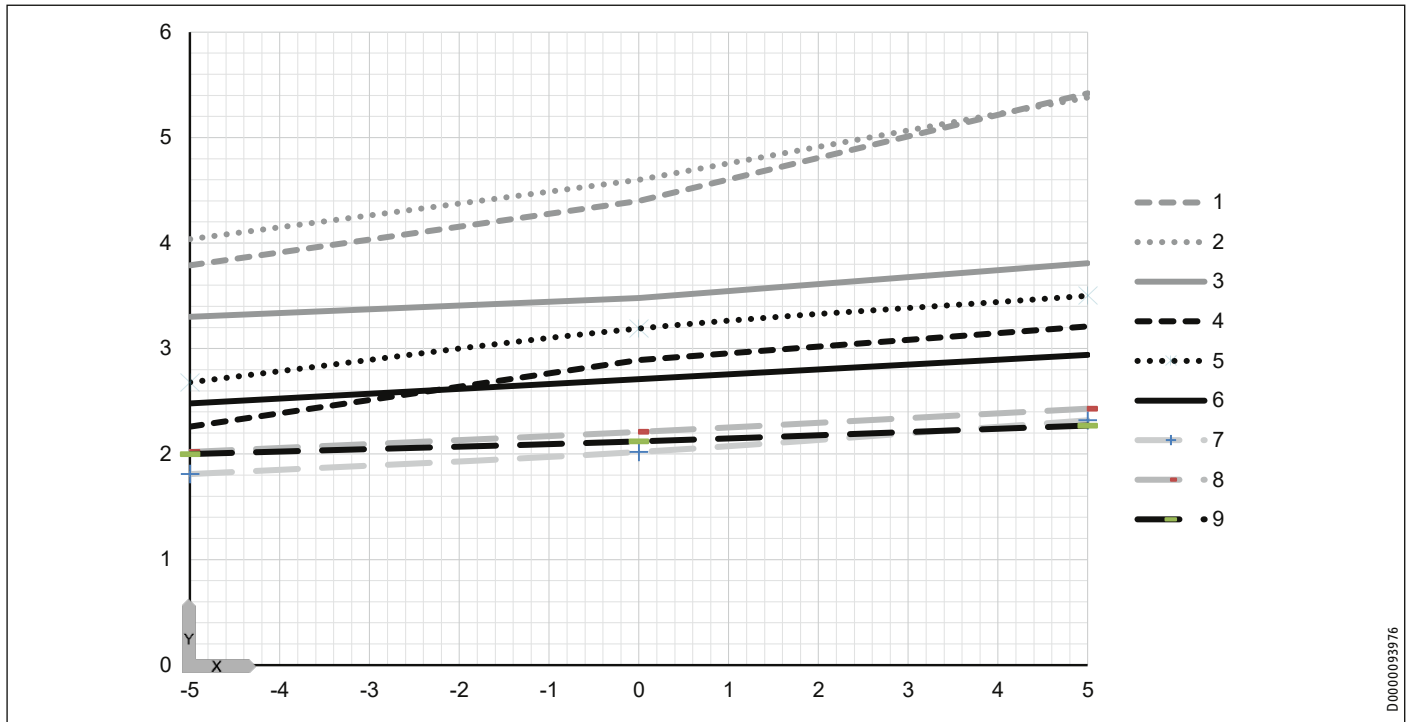

	X Inlet temperature of the WQA medium [°C]	Y Coefficient of performance e [-]
Flow temperature	35 °C	55 °C
Output	1 1 % 2 50 % 3 100 %	4 1 % 5 50 % 6 100 %

Cooling capacity

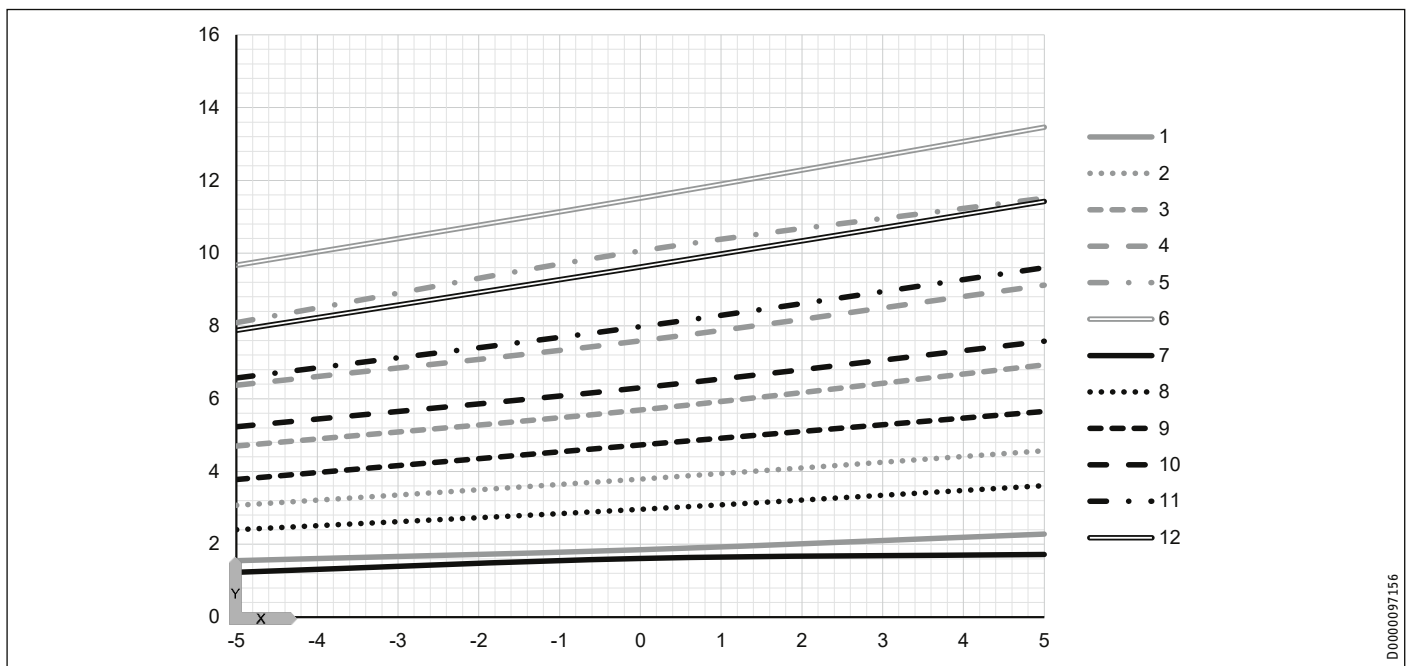

	X Inlet temperature of the WQA medium [°C]	Y Cooling capacity [kW]
Flow temperature	35 °C	55 °C
Output [Hz]	1 Min. 2 40 3 60 4 80 5 100 6 Max.	7 Min. 8 40 9 60 10 80 11 100 12 Max.

INSTALLATION Specification

16.4 Data table

16.4.1 HPG-I DS Premium

Output details apply to new appliances with clean heat exchangers.

The power consumption figures for the integral auxiliary drives are maximum values and may vary subject to operating point.

The power consumption of the integral auxiliary drives is included in the output details of the heat pump (to EN 14511).

		HPG-I 04 DS Premium	HPG-I 06 DS Premium	HPG-I 08 DS Premium	HPG-I 12 DS Premium	HPG-I 15 DS Premium
		202622	202623	202624	202625	202626
Heating output						
Heating output at B0/W35 (EN 14511)	kW	1.96	2.37	2.78	4.19	5.18
Heating output at B0/W35 (min./max.)	kW	1.0 - 4.2	1.0 - 6.6	1.0 - 7.6	2.1 - 12.7	2.1 - 14.8
Heating output at B0/W55 (EN 14511)	kW	1.28	2.01	2.42	4.2	4.72
Power consumption						
Power consumption at B0/W35 (EN 14511)	kW	0.43	0.45	0.6	0.84	1.07
Power consumption at B0/W55 (EN 14511)	kW	0.47	0.69	0.79	1.34	1.48
Power consumption, emergency/booster heater	kW	5.9	5.9	5.9	5.9	5.9
Max. power consumption, circulation pump, heating side	W	45	45	45	76	76
Max. power consumption, circulation pump, source side	W	140	140	140	140	140
Coefficients of performance						
SCOP (EN 14825)		5.07	5.2	5.12	5.59	5.44
COP at B0/W35 (EN 14511)		4.6	4.6	4.67	5.01	4.86
COP at B0/W55 (EN 14511)		2.73	2.91	3.07	3.13	3.18
Sound emissions						
Sound power level (EN 12102)	dB(A)	43 - 46	43 - 48	43 - 48	43 - 49	43 - 49
Application limits						
Permissible operating pressure, cylinder	MPa	1	1	1	1	1
Max. heating flow temperature	°C	75	75	75	75	75
Min. application limit on heating side	°C	15	15	15	15	15
Min./max. application limits for heat source	°C	-5/+20	-5/+20	-5/+20	-5/+20	-5/+20
Shutdown pressure, brine pressure switch (positive pressure)	MPa	0.07	0.07	0.07	0.07	0.07
Hydraulic data						
Cylinder capacity V	l	175	175	175	162	162
Surface area, heat exchanger	m ²	2.1	2.1	2.1	3.5	3.5
Energy data						
Energy efficiency class, moderate climate, W55/W35		A+++/A+++	A+++/A+++	A+++/A+++	A+++/A+++	A+++/A+++
Energy efficiency class, DHW heating with load profile XL		A	A	A	A	A
Standby energy consumption/ 24 h at 65 °C	kWh	1.9	1.9	1.9	1.9	1.9
Electrical data						
Starting current (with/without starting current limiter)	A	<6	<6	<6	<10	<10
Emergency/booster heater fuse protection	A	2 x B 16	2 x B 16	2 x B 16	2 x B 16	2 x B 16
Control unit fuse protection	A	1 x B 16	1 x B 16	1 x B 16	1 x B 16	1 x B 16
Compressor fuse protection	A	1 x B 16	1 x B 16	1 x B 16	1 x B 25	1 x B 25
Rated voltage, emergency/booster heater	V	230	230	230	230	230
Rated voltage, control unit	V	230	230	230	230	230
Rated voltage, compressor	V	230	230	230	230	230
Frequency	Hz	50	50	50	50	50
Phases, emergency/booster heater		2/N/PE	2/N/PE	2/N/PE	2/N/PE	2/N/PE
Phases, control unit		1/N/PE	1/N/PE	1/N/PE	1/N/PE	1/N/PE
Phases, compressor		1/N/PE	1/N/PE	1/N/PE	1/N/PE	1/N/PE
Max. operating current	A	8.36	13.01	15.09	24.32	24.48

INSTALLATION Specification

		HPG-I 04 DS Premium	HPG-I 06 DS Premium	HPG-I 08 DS Premium	HPG-I 12 DS Premium	HPG-I 15 DS Premium
Versions						
Refrigerant		R454 C	R454 C	R454 C	R454 C	R454 C
Refrigerant charge	kg	2.2	2.2	2.2	3.1	3.1
CO ₂ equivalent (CO ₂ e)	t	0.32	0.32	0.32	0.45	0.45
Global warming potential of the refrigerant (GWP100)		148	148	148	148	148
Compressor oil		Diamond Freeze MA68	Diamond Freeze MA68	Diamond Freeze MA68	Diamond Freeze MA68	Diamond Freeze MA68
Condenser material		1.4401/Cu	1.4401/Cu	1.4401/Cu	1.4401/Cu	1.4401/Cu
Evaporator material		1.4401/Cu	1.4401/Cu	1.4401/Cu	1.4401/Cu	1.4401/Cu
Circulation pump type, heating side		Yonos PARA 25/7.0	Yonos PARA 25/7.0	Yonos PARA 25/7.0	Yonos PARA 25/7.5	Yonos PARA 25/7.5
Circulation pump type, source side		Grundfos UPML	Grundfos UPML	Grundfos UPML	Grundfos UPML	Grundfos UPML
IP rating		IP20	IP20	IP20	IP20	IP20
Dimensions						
Height	mm	1940	1940	1940	1940	1940
Width	mm	600	600	600	600	600
Depth	mm	719	719	719	719	719
Height when tilted	mm	2020	2020	2020	2020	2020
Weights						
Weight, empty	kg	265	265	265	275	275
Weight, full	kg	427	427	427	437	437
Weight	kg	265	265	265	275	275
Connections						
DHW flow/return push-fit connection		22 mm	22 mm	22 mm	22 mm	22 mm
Heat source flow/return push-fit connection		28 mm	28 mm	28 mm	28 mm	28 mm
Heating flow/return push-fit connection		22 mm	22 mm	22 mm	22 mm	22 mm
DHW circulation connection		G 1/2 A	G 1/2 A	G 1/2 A	G 1/2 A	G 1/2 A
Heating water quality requirements						
Water hardness	°dH	≤3	≤3	≤3	≤3	≤3
pH value (with aluminium fittings)		8.0 - 8.5	8.0 - 8.5	8.0 - 8.5	8.0 - 8.5	8.0 - 8.5
pH value (without aluminium fittings)		8.0 - 10.0	8.0 - 10.0	8.0 - 10.0	8.0 - 10.0	8.0 - 10.0
Chloride	mg/l	<30	<30	<30	<30	<30
Conductivity (desalination)	µS/cm	20-100	20-100	20-100	20-100	20-100
Conductivity (softening)	µS/cm	<1000	<1000	<1000	<1000	<1000
Oxygen 8-12 weeks after filling (desalination)	mg/l	<0.1	<0.1	<0.1	<0.1	<0.1
Oxygen 8-12 weeks after filling (softening)	mg/l	<0.02	<0.02	<0.02	<0.02	<0.02
Heat transfer medium requirements on the heat source side						
Ethylene glycol concentration, geothermal collector	Vol.-%	33	33	33	33	33
Ethylene glycol concentration, geothermal probe	Vol.-%	25	25	25	25	25
Values						
Min. flow rate, heating	m ³ /h	0.3	0.3	0.3	0.3	0.3
Heating flow rate (EN 14511) at A7/W35, B0/W35 and 5 K	m ³ /h	0.34	0.41	0.48	0.74	0.9
Nominal heating flow rate at B0/W35 and 8 K	m ³ /h	0.45	0.71	0.81	1.36	1.59
Available external pressure differential, heating, nominal at B0/W35 and 8 K	hPa	708	642	603	571	462
flow rate on heat source side at B0/W35 and 3 K	m ³ /h	0.5	0.6	0.68	1.08	1.31
Max. flow rate on heat source side at B0/W35 and 3 K	m ³ /h	1.05	1.61	1.82	3.1	3.55
Max. available external pressure differential on heat source side at B0/W35 and 3 K	hPa	927	702	590	319	74
Internal volume, heating side	l	19.5	19.5	19.5	25.6	25.6
Internal volume, source side	l	2.5	2.5	2.5	3.9	3.9
Permissible operating pressure, heating circuit	MPa	0.3	0.3	0.3	0.3	0.3

Conversion: 1 m³/h = 16.67 l/min

Further details

		HPG-I 04 DS Premium	HPG-I 06 DS Premium	HPG-I 08 DS Premium	HPG-I 12 DS Premium	HPG-I 15 DS Premium
		202622	202623	202624	202625	202626
Maximum altitude for installation	m	2000	2000	2000	2000	2000

INSTALLATION Specification

16.4.2 HPG-I DCS Premium

Output details apply to new appliances with clean heat exchangers.

The power consumption figures for the integral auxiliary drives are maximum values and may vary subject to operating point.

The power consumption of the integral auxiliary drives is included in the output details of the heat pump (to EN 14511).

		HPG-I 04 DCS Premi- um	HPG-I 06 DCS Premi- um	HPG-I 08 DCS Premi- um	HPG-I 12 DCS Premi- um	HPG-I 15 DCS Premi- um
		202632	202633	202634	202635	202636
Heating output						
Heating output at B0/W35 (EN 14511)	kW	1.96	2.37	2.78	4.19	5.18
Heating output at B0/W35 (min./max.)	kW	1.0 - 4.2	1.0 - 6.6	1.0 - 7.6	2.1 - 12.7	2.1 - 14.8
Heating output at B0/W55 (EN 14511)	kW	1.28	2.01	2.42	4.2	4.72
Cooling capacity at B15/W23	kW	2.5	3	4	6	8
Power consumption						
Power consumption at B0/W35 (EN 14511)	kW	0.43	0.45	0.6	0.84	1.07
Power consumption at B0/W55 (EN 14511)	kW	0.47	0.69	0.79	1.34	1.48
Power consumption, emergency/booster heater	kW	5.9	5.9	5.9	5.9	5.9
Max. power consumption, circulation pump, heating side	W	45	45	45	76	76
Max. power consumption, circulation pump, source side	W	140	140	140	140	140
Coefficients of performance						
SCOP (EN 14825)		5.07	5.2	5.12	5.59	5.44
COP at B0/W35 (EN 14511)		4.6	4.6	4.67	5.01	4.86
COP at B0/W55 (EN 14511)		2.73	2.91	3.07	3.13	3.18
Sound emissions						
Sound power level (EN 12102)	dB(A)	43 - 46	43 - 48	43 - 48	43 - 49	43 - 49
Application limits						
Permissible operating pressure, cylinder	MPa	1	1	1	1	1
Max. heating flow temperature	°C	75	75	75	75	75
Min. application limit on heating side	°C	15	15	15	15	15
Min./max. application limits for heat source	°C	-5/+20	-5/+20	-5/+20	-5/+20	-5/+20
Shutdown pressure, brine pressure switch (positive pressure)	MPa	0.07	0.07	0.07	0.07	0.07
Hydraulic data						
Cylinder capacity V	l	175	175	175	162	162
Surface area, heat exchanger	m ²	2.1	2.1	2.1	3.5	3.5
Energy data						
Energy efficiency class, moderate climate, W55/W35		A+++ / A+++	A+++ / A+++	A+++ / A+++	A+++ / A+++	A+++ / A+++
Energy efficiency class, DHW heating with load profile XL		A	A	A	A	A
Standby energy consumption/ 24 h at 65 °C	kWh	1.9	1.9	1.9	1.9	1.9
Electrical data						
Starting current (with/without starting current limiter)	A	<6	<6	<6	<10	<10
Emergency/booster heater fuse protection	A	2 x B 16	2 x B 16	2 x B 16	2 x B 16	2 x B 16
Control unit fuse protection	A	1 x B 16	1 x B 16	1 x B 16	1 x B 16	1 x B 16
Compressor fuse protection	A	1 x B 16	1 x B 16	1 x B 16	1 x B 25	1 x B 25
Rated voltage, emergency/booster heater	V	230	230	230	230	230
Rated voltage, control unit	V	230	230	230	230	230
Rated voltage, compressor	V	230	230	230	230	230
Frequency	Hz	50	50	50	50	50
Phases, emergency/booster heater		2/N/PE	2/N/PE	2/N/PE	2/N/PE	2/N/PE
Phases, control unit		1/N/PE	1/N/PE	1/N/PE	1/N/PE	1/N/PE
Phases, compressor		1/N/PE	1/N/PE	1/N/PE	1/N/PE	1/N/PE
Max. operating current	A	8.36	13.1	15.09	24.32	24.48

INSTALLATION Specification

		HPG-I 04 DCS Premi- um	HPG-I 06 DCS Premi- um	HPG-I 08 DCS Premi- um	HPG-I 12 DCS Premi- um	HPG-I 15 DCS Premi- um
Versions						
Refrigerant		R454 C	R454 C	R454 C	R454 C	R454 C
Refrigerant charge	kg	2.2	2.2	2.2	3.1	3.1
CO ₂ equivalent (CO ₂ e)	t	0.32	0.32	0.32	0.45	0.45
Global warming potential of the refrigerant (GWP100)		148	148	148	148	148
Compressor oil		Diamond Freeze MA68	Diamond Freeze MA68	Diamond Freeze MA68	Diamond Freeze MA68	Diamond Freeze MA68
Condenser material		1.4401/Cu	1.4401/Cu	1.4401/Cu	1.4401/Cu	1.4401/Cu
Evaporator material		1.4401/Cu	1.4401/Cu	1.4401/Cu	1.4401/Cu	1.4401/Cu
Circulation pump type, heating side		Yonos PARA 25/7.0	Yonos PARA 25/7.0	Yonos PARA 25/7.0	Yonos PARA 25/7.5	Yonos PARA 25/7.5
Circulation pump type, source side		Grundfos UPML	Grundfos UPML	Grundfos UPML	Grundfos UPML	Grundfos UPML
IP rating		IP20	IP20	IP20	IP20	IP20
Dimensions						
Height	mm	1940	1940	1940	1940	1940
Width	mm	600	600	600	600	600
Depth	mm	719	719	719	719	719
Height when tilted	mm	2020	2020	2020	2020	2020
Weights						
Weight, empty	kg	265	265	265	275	275
Weight, full	kg	427	427	427	437	437
Weight	kg	265	265	265	275	275
Connections						
DHW flow/return push-fit connection		22 mm	22 mm	22 mm	22 mm	22 mm
Heat source flow/return push-fit connection		28 mm	28 mm	28 mm	28 mm	28 mm
Heating flow/return push-fit connection		22 mm	22 mm	22 mm	22 mm	22 mm
DHW circulation connection		G 1/2 A	G 1/2 A	G 1/2 A	G 1/2 A	G 1/2 A
Heating water quality requirements						
Water hardness	°dH	≤3	≤3	≤3	≤3	≤3
pH value (with aluminium fittings)		8.0-8.5	8.0-8.5	8.0-8.5	8.0-8.5	8.0-8.5
pH value (without aluminium fittings)		8.0-10.0	8.0-10.0	8.0-10.0	8.0-10.0	8.0-10.0
Chloride	mg/l	<30	<30	<30	<30	<30
Conductivity (desalination)	µS/cm	20-100	20-100	20-100	20-100	20-100
Conductivity (softening)	µS/cm	<1000	<1000	<1000	<1000	<1000
Oxygen 8-12 weeks after filling (desalination)	mg/l	<0.1	<0.1	<0.1	<0.1	<0.1
Oxygen 8-12 weeks after filling (softening)	mg/l	<0.02	<0.02	<0.02	<0.02	<0.02
Heat transfer medium requirements on the heat source side						
Ethylene glycol concentration, geothermal collector	Vol.-%	33	33	33	33	33
Ethylene glycol concentration, geothermal probe	Vol.-%	25	25	25	25	25
Values						
Min. flow rate, heating	m ³ /h	0.3	0.3	0.3	0.3	0.3
Heating flow rate (EN 14511) at A7/W35, B0/W35 and 5 K	m ³ /h	0.34	0.41	0.48	0.74	0.9
Nominal heating flow rate at B0/W35 and 8 K	m ³ /h	0.45	0.71	0.81	1.36	1.59
Available external pressure differential, heating, nominal at B0/W35 and 8 K	hPa	708	642	603	571	462
flow rate on heat source side at B0/W35 and 3 K	m ³ /h	0.5	0.6	0.68	1.08	1.31
Max. flow rate on heat source side at B0/W35 and 3 K	m ³ /h	1.05	1.61	1.82	3.1	3.55
Max. available external pressure differential on heat source side at B0/W35 and 3 K	hPa	927	702	590	319	74
Internal volume, heating side	l	19.5	19.5	19.5	25.6	25.6
Internal volume, source side	l	2.5	2.5	2.5	3.9	3.9
Permissible operating pressure, heating circuit	MPa	0.3	0.3	0.3	0.3	0.3

Conversion: 1 m³/h = 16.67 l/min

Further details

		HPG-I 04 DCS Pre- mium	HPG-I 06 DCS Pre- mium	HPG-I 08 DCS Pre- mium	HPG-I 12 DCS Premium	HPG-I 15 DCS Premium
		202632	202633	202634	202635	202636
Maximum altitude for installation	m	2000	2000	2000	2000	2000

Guarantee

The guarantee conditions of our German companies do not apply to appliances acquired outside of Germany. In countries where our subsidiaries sell our products a guarantee can only be issued by those subsidiaries. Such guarantee is only granted if the subsidiary has issued its own terms of guarantee. No other guarantee will be granted.

We shall not provide any guarantee for appliances acquired in countries where we have no subsidiary to sell our products. This will not affect warranties issued by any importers.

Environment and recycling

We would ask you to help protect the environment. After use, dispose of the various materials in accordance with national regulations.

NOTES

NOTES

NOTES

Deutschland

STIEBEL ELTRON GmbH & Co. KG
Dr.-Stiebel-Straße 33 | 37603 Holzminden
Tel. 05531 702-0 | Fax 05531 702-480
info@stiebel-eltron.de
www.stiebel-eltron.de

Verkauf

Kundendienst
Ersatzteilverkauf

Tel. 05531 702-110 | Fax 05531 702-95108 | info-center@stiebel-eltron.de
Tel. 05531 702-111 | Fax 05531 702-95890 | kundendienst@stiebel-eltron.de
www.stiebel-eltron.de/ersatzteile | ersatzteile@stiebel-eltron.de

Australia

STIEBEL ELTRON Australia Pty. Ltd.
294 Salmon Street | Port Melbourne VIC 3207
Tel. 03 9645-1833 | Fax 03 9644-5091
info@stiebel-eltron.com.au
www.stiebel-eltron.com.au

Austria

STIEBEL ELTRON Ges.m.b.H.
Gewerbegebiet Neubau-Nord
Margaritenstraße 4 A | 4063 Hörsching
Tel. 07221 74600-0 | Fax 07221 74600-42
info@stiebel-eltron.at
www.stiebel-eltron.at

Belgium

STIEBEL ELTRON bvba/sprl
't Hofveld 6 - D1 | 1702 Groot-Bijgaarden
Tel. 02 42322-22 | Fax 02 42322-12
info@stiebel-eltron.be
www.stiebel-eltron.be

China

STIEBEL ELTRON (Tianjin) Electric Appliance Co., Ltd.
Plant C3, XEDA International Industry City
Xiqing Economic Development Area
300385 Tianjin
Tel. 022 8396 2077 | Fax 022 8396 2075
info@stiebeleltron.cn
www.stiebeleltron.cn

Czech Republic

STIEBEL ELTRON spol. s r.o.
Dopraváků 749/3 | 184 00 Praha 8
Tel. 251116-111 | Fax 235512-122
info@stiebel-eltron.cz
www.stiebel-eltron.cz

Finland

STIEBEL ELTRON OY
Kapinakuja 1 | 04600 Mäntsälä
Tel. 020 720-9988
info@stiebel-eltron.fi
www.stiebel-eltron.fi

France

STIEBEL ELTRON SAS
7-9, rue des Selliers
B.P 85107 | 57073 Metz-Cédex 3
Tel. 0387 7438-88 | Fax 0387 7468-26
info@stiebel-eltron.fr

Hungary

STIEBEL ELTRON Kft.
Gyár u. 2 | 2040 Budaörs
Tel. 01 250-6055 | Fax 01 368-8097
info@stiebel-eltron.hu
www.stiebel-eltron.hu

Japan

NIHON STIEBEL Co. Ltd.
Kowa Kawasaki Nishiguchi Building 8F
66-2 Horikawa-Cho
Saiwai-Ku | 212-0013 Kawasaki
Tel. 044 540-3200 | Fax 044 540-3210
info@nihonstiebel.co.jp
www.nihonstiebel.co.jp

Netherlands

STIEBEL ELTRON Nederland B.V.
Daviottenweg 36 | 5222 BH 's-Hertogenbosch
Tel. 073 623-0000 | Fax 073 623-1141
info@stiebel-eltron.nl
www.stiebel-eltron.nl

New Zealand

Stiebel Eltron NZ Limited
61 Barrys Point Road | Auckland 0622
Tel. +64 9486 2221
info@stiebel-eltron.co.nz
www.stiebel-eltron.co.nz

Poland

STIEBEL ELTRON Polska Sp. z O.O.
ul. Działkowa 2 | 02-234 Warszawa
Tel. 022 60920-30 | Fax 022 60920-29
biuro@stiebel-eltron.pl
www.stiebel-eltron.pl

Russia

STIEBEL ELTRON LLC RUSSIA
Urzhumskaya street 4,
building 2 | 129343 Moscow
Tel. +7 495 125 0 125
info@stiebel-eltron.ru
www.stiebel-eltron.ru

Slovakia

STIEBEL ELTRON Slovakia, s.r.o.
Hlavná 1 | 058 01 Poprad
Tel. 052 7127-125 | Fax 052 7127-148
info@stiebel-eltron.sk
www.stiebel-eltron.sk

South Africa

STIEBEL ELTRON Southern Africa (PTY) Ltd
30 Archimedes Road
Wendywood
Johannesburg, 2090
Tel. +27 10 001 85 47
info@stiebel-eltron.co.za
www.stiebel-eltron.co.za

Switzerland

STIEBEL ELTRON AG
Industrie West
Gass 8 | 5242 Lupfig
Tel. 056 4640-500 | Fax 056 4640-501
info@stiebel-eltron.ch
www.stiebel-eltron.ch

Thailand

STIEBEL ELTRON Asia Ltd.
469 Moo 2 Tambol Klong-Jik
Amphur Bangpa-In | 13160 Ayutthaya
Tel. 035 220088 | Fax 035 221188
info@stiebeleltronasia.com
www.stiebeleltronasia.com

United Kingdom and Ireland

STIEBEL ELTRON UK Ltd.
Unit 12 Stadium Court
Stadium Road | CH62 3RP Bromborough
Tel. 0151 346-2300 | Fax 0151 334-2913
info@stiebel-eltron.co.uk
www.stiebel-eltron.co.uk

United States of America

STIEBEL ELTRON, Inc.
17 West Street | 01088 West Hatfield MA
Tel. 0413 247-3380 | Fax 0413 247-3369
info@stiebel-eltron-usa.com
www.stiebel-eltron-usa.com

STIEBEL ELTRON



Irrtum und technische Änderungen vorbehalten! | Subject to errors and technical changes! | Sous réserve d'erreurs et de modifications techniques! | Onder voorbehoud van vergissingen en technische wijzigingen! | Salvo error o modificación técnica! | Excepto erro ou alteração técnica | Zastrzeżone zmiany techniczne i ewentualne błędy | Omyly a technické změny jsou vyhrazeny! | A muszaki változtatások és tévedések jogát fenntartjuk! | Отсутствие ошибок не гарантируется. Возможны технические изменения. | Chyby a technické zmeny sú vyhradené! | Stand 9734