

OPERATION AND INSTALLATION

Ground source heat pump

- » HPG-I 04 S Premium
- » HPG-I 06 S Premium
- » HPG-I 08 S Premium
- » HPG-I 12 S Premium
- » HPG-I 15 S Premium
- » HPG-I 04 CS Premium
- » HPG-I 06 CS Premium
- » HPG-I 08 CS Premium
- » HPG-I 12 CS Premium
- » HPG-I 15 CS Premium

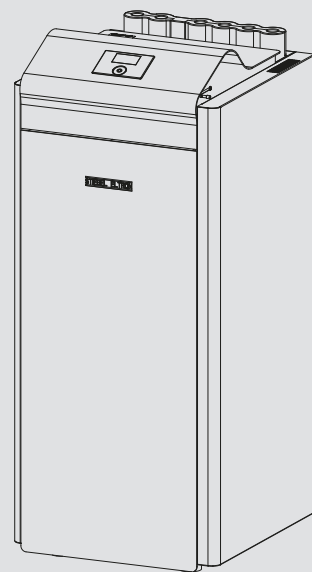

STIEBEL ELTRON

CONTENTS

SPECIAL INFORMATION

OPERATION

1. General information	4
1.1 Relevant documents	4
1.2 Safety instructions	4
1.3 Other symbols in this documentation	4
1.4 Information on the unit	4
1.5 Units of measurement	4
1.6 Standardised output data	4
2. Safety	5
2.1 Intended use	5
2.2 Safety instructions	5
2.3 Test symbols	5
3. Appliance description	5
4. Maintenance and care	6
5. Troubleshooting	6

INSTALLATION

6. Safety	6
6.1 General safety instructions	6
6.2 Instructions, standards and regulations	6
7. Appliance description	6
7.1 Function	6
7.2 Standard delivery	6
7.3 Accessories	6
8. Preparation	7
8.1 Safety concept	7
8.2 Installation site	7
8.3 Minimum clearances	8
8.4 Electrical installation	8
9. Installation	9
9.1 Transport	9
9.2 Siting	9
9.3 Installing the heat source system	9
9.4 Heating water connection	11
9.5 Oxygen diffusion	11
9.6 Filling the heating system	12
9.7 Venting the heating system	13
9.8 DHW heating	13
9.9 Operation with buffer cylinder	13
9.10 Fitting the push-fit connectors	13
10. Electrical connection	14
10.1 General	14
10.2 Electrical connection	14
10.3 High limit safety cut-out for area heating system	16
10.4 Sensor installation	16
11. Commissioning	16
11.1 Checks before commissioning	16
11.2 Initial start-up	17
12. Appliance handover	18
13. Appliance shutdown	18
13.1 Standby mode	18
13.2 Power interruption	18

14. Troubleshooting	18
14.1 Removing the casing parts	18
14.2 Resetting the high limit safety cut-out	19
14.3 Resetting the compressor tempering device	19
14.4 Checking the IWS DIP switch settings	20
14.5 LEDs (IWS)	20
14.6 Reset button	21
15. Maintenance	21
16. Specification	22
16.1 Dimensions and connections	22
16.2 Wiring diagram	24
16.3 Output diagrams	32
16.4 Data table	42

GUARANTEE

ENVIRONMENT AND RECYCLING

SPECIAL INFORMATION

- The appliance may be used by children over 8 years of age and persons with reduced physical, sensory or mental capabilities or a lack of experience and expertise, provided that they are supervised or they have been instructed on how to use the appliance safely and have understood the potential risks. Children must never play with the appliance. Cleaning and user maintenance must not be carried out by children without supervision.
- The connection to the power supply must be in the form of a permanent connection. Ensure the appliance can be separated from the power supply by an isolator that disconnects all poles with at least 3 mm contact separation.
- Maintain the minimum clearances to ensure trouble-free operation of the appliance and facilitate maintenance work.
- In dual mode operation, return water from the second heat generator may flow through the heat pump. Please note that the return water temperature may be a maximum of 65 °C.
- Maintenance work, such as checking the electrical safety, must only be carried out by a qualified contractor.
- We recommend regular inspection (to establish the current condition of the system), and maintenance by a qualified contractor if required (to return the system to its original condition).
- Following disconnection from the power supply, parts of the appliance may remain energised for 5 minutes until the inverter capacitors have discharged.
- Never interrupt the power supply, even outside the heating season. The system's active frost protection is not guaranteed if the power supply is interrupted.

- There is no need to shut the system down in summer. The heat pump manager has an automatic summer/winter changeover.

HPG-I CS Premium

- The appliance is only suitable for passive cooling.
- In the delivered condition, the COOLING parameter is set to OFF.
- The COOLING menu will only be displayed if a FET is connected. Cooling mode is only possible in summer mode.

OPERATION

1. General information

The chapters "Special information" and "Operation" are intended for both users and qualified contractors.



The chapter "Installation" is intended for qualified contractors.



Note

Read these instructions carefully before using the appliance and retain them for future reference. Pass on these instructions to a new user if required.

1.1 Relevant documents

-  Operating instructions for the WPM heat pump manager
-  Commissioning instructions for the WPM heat pump manager
-  Operating and installation instructions for system components

1.2 Safety instructions

1.2.1 Structure of safety instructions





KEYWORD Type of risk

Here, possible consequences are listed that may result from failure to observe the safety instructions.

► Steps to prevent the risk are listed.

1.2.2 Symbols, type of risk

Symbol	Type of risk
	Injury
	Electrocution

1.2.3 Keywords

KEYWORD	Meaning
DANGER	Failure to observe this information will result in serious injury or death.
WARNING	Failure to observe this information may result in serious injury or death.
CAUTION	Failure to observe this information may result in non-serious or minor injury.



1.3 Other symbols in this documentation



Note







General information is identified by the adjacent symbol.

► Read these texts carefully.

Symbol	Meaning
	Material losses (appliance damage, consequential losses and environmental pollution)
	Appliance disposal

► This symbol indicates that you have to do something. The action you need to take is described step by step.

1.4 Information on the unit

Symbol	Meaning
	Refrigerant with low flammability
	Inlet / intake
	Drain / outlet
	Heat source
	Heating
	Potable water
	Never cover the appliance

1.5 Units of measurement



Note

All measurements are given in mm unless stated otherwise.

1.6 Standardised output data

Information on determining and interpreting the specified standardised output data.

1.6.1 EN 14511

The output data specifically mentioned in text, diagrams and technical datasheets has been determined in line with the test conditions described in the standard shown in the heading of this chapter. However, there is a partial deviation from this norm in the output data for inverter heat pumps, as this concerns partial load values. The associated percentage weighting in the partial load range can be found in EN 14825 and EHPA quality label regulations.

Generally, the test conditions stated above will not fully match the conditions found at the installation site of the system user.

Depending on the chosen test method and the extent to which this method differs from the test conditions defined in the first paragraph of this section, any deviations can be considerable.

Additional factors that have an influence on the test values are the measuring equipment, the system configuration, the age of the system and the flow rates.

Confirmation of the specified output data can only be obtained if the test conducted for this purpose is also performed in accordance with the test conditions defined in the first paragraph of this section.

2. Safety

2.1 Intended use

The appliance is designed for:

- Heating rooms
- Heating of DHW
- Cooling rooms (only HPG-I CS Premium)

Observe the operating limits listed in chapter "Specification".

The appliance is intended for domestic use. It can be used safely by untrained persons. The appliance can also be used in non-domestic environments, e.g. in small businesses, as long as it is used in the same way.

Any other use beyond that described shall be deemed inappropriate. Observation of these instructions and of instructions for any accessories used is also part of the correct use of this appliance.

2.2 Safety instructions

- Only recognised, qualified contractors may carry out the electrical work and installation of the heating circuit.
- The qualified contractor is responsible for adherence to all applicable regulations during installation and commissioning.
- The appliance should only be operated once it is fully installed and all safety equipment has been fitted.
- Protect the appliance from dust and dirt during building work.
- Observe the safety concept for operation of the appliance (see chapter "Preparation / Safety concept").



WARNING Injury

The appliance may be used by children over 8 years of age and persons with reduced physical, sensory or mental capabilities or a lack of experience and expertise, provided that they are supervised or they have been instructed on how to use the appliance safely and have understood the potential risks. Children must never play with the appliance. Cleaning and user maintenance must not be carried out by children without supervision.



WARNING Injury

- For safety reasons, only operate the appliance with the casing closed.

2.3 Test symbols

See type plate on the appliance.

3. Appliance description

The appliance is a ground source heat pump suitable for operation as a heating heat pump. The heat pump extracts energy from the heat source medium at a low temperature level. This extracted energy is then transferred to the heating water at a higher level, augmented by the electric energy drawn by the compressor. The heating water is heated to a flow temperature of up to 75 °C, depending on the heat source temperature.

A heating circulation pump, a multifunction assembly (MFG) with safety assembly and a 3-way valve are integrated in the appliance for switching between the heating circuit and the DHW circuit. To heat the DHW, the heating water that has been heated by the heat pump is directed through an indirect coil in the DHW cylinder, where it transfers its energy to the DHW.

The appliance is equipped with an electric emergency/booster heater (NHZ). To safeguard heating operation and the provision of high DHW temperatures, the electric emergency/booster heater is activated as an emergency heater if the dual mode point is undershot in mono mode operation. If the same thing happens in mono energetic operation, the electric emergency/booster heater is activated as a booster heater.

The appliance is controlled with an integral, outside temperature-dependent heating circuit temperature control unit (WPM heat pump manager).

The WPM also controls the DHW heating to the required temperature. DHW heating will be completed automatically by an integral electric emergency/booster heater, if either the high pressure sensor or the hot gas limiter of the heat pump responds during DHW heating, subject to the WW LEARNING FUNCTION being deactivated. Also subject to the WW LEARNING FUNCTION being activated, the DHW heating will terminate and the set DHW value will be overwritten with the actual DHW temperature that has been achieved.

The WPM also controls the integral electric emergency/booster heater. An additional heat generator can also be controlled.

Screed drying



Material losses

Incorrect settings can cause damage to the heat pump or screed. With ground source heat pumps, the heat source can also be damaged.

- If you want to use the heat-up program, observe the corresponding chapter in the commissioning instructions for the WPM heat pump manager.

HPG-I CS Premium



Material losses

In cooling mode, condensate can form when the dew point temperature is undershot.

- Make the electrical connection for the FET remote control.



Material losses

Condensation caused by the temperature falling below the dew point can lead to material losses. The appliance is approved solely for area cooling. Once the FET remote control is connected, the WPM heat pump manager takes control of dew point monitoring.

An additional heat exchanger and 3-way valve for switching between heating and cooling are integrated into the appliance.

Area cooling requires the installation of a remote control unit (FET) in a reference room to capture the relative humidity and the room temperature as part of dew point monitoring.

To cool the living space, the brine is pumped through the additional heat exchanger. There, heat is extracted from the heating water to be released into the cooler zones underground.

The compressor does not run during cooling.

4. Maintenance and care



Material losses

Only qualified contractors may perform maintenance work, such as electrical safety checks.

A damp cloth is sufficient for cleaning all plastic and sheet metal parts. Never use abrasive or corrosive cleaning agents.

We recommend regular inspection (to establish the current condition of the system), and maintenance by a qualified contractor if required (to return the system to its original condition).

5. Troubleshooting

Fault	Cause	Remedy
There is no hot water or the heating system remains cold.	The fuse/MCB has blown/ responded.	Check the fuses / MCBs in your fuse box / distribution board.

If you cannot remedy the fault, contact your qualified contractor. To facilitate and speed up your request, provide the number from the type plate. The type plate is located at the front top, on the right or left-hand side of the casing.

Sample type plate

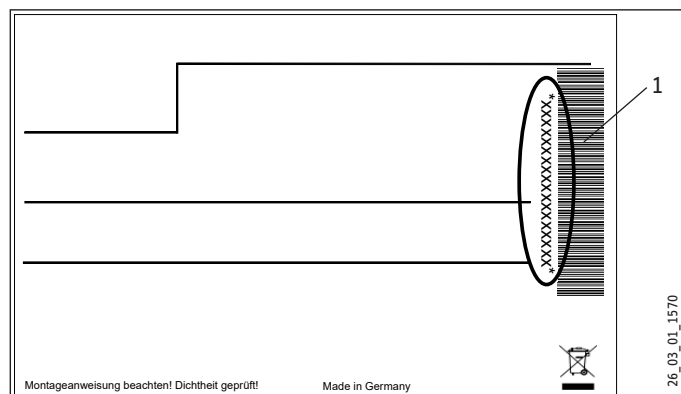

1 Number on the type plate

INSTALLATION

6. Safety

Only a qualified contractor should carry out installation, commissioning, maintenance and repair of the appliance.

6.1 General safety instructions

We guarantee trouble-free function and operational reliability only if original accessories and spare parts intended for the appliance are used.

6.2 Instructions, standards and regulations



Note

Observe all applicable national and regional regulations and instructions.

7. Appliance description

7.1 Function

The heat exchanger on the heat source side (evaporator) extracts natural heat from the heat source. This extracted energy and the energy drawn by the compressor drive is transferred to the heating water by a heat exchanger on the heating water side (condenser). Subject to the heat load, the heating water is heated up to +75 °C.

The electric emergency/booster heater starts if the high pressure sensor or the hot gas limiter responds during DHW heating. If the heat demand of the heating system exceeds the heating output of the heat pump, the emergency/booster heater covers the residual heat demand.

HPG-I CS Premium

For cooling, the brine is pumped through a 3-way diverter valve and a second heat exchanger. The brine extracts heat from the heating water.

7.2 Standard delivery

- 1x Outside temperature sensor AF PT
- 2x TAF PT immersion/contact sensor
- 6x Push-fit connectors 28 mm

7.3 Accessories

- Brine filling unit WPSF
- Water softening fitting HZEA
- Filter assembly 22 mm (FS-WP 22)
- Filter assembly 28 mm (FS-WP 28)
- FET remote control
- TAF PT immersion/contact sensor

8. Preparation

8.1 Safety concept



Never cover the appliance

► Keep the discharge and intake apertures clear.

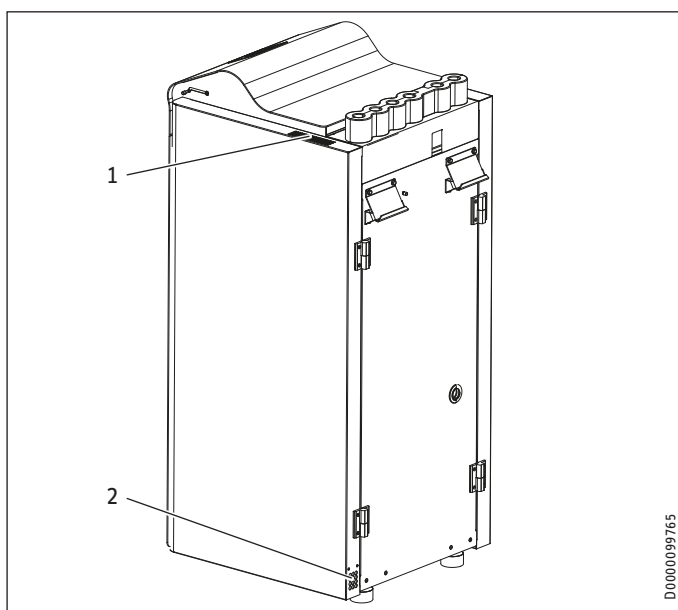

- 1 Discharge aperture
- 2 Intake aperture

A fan is installed in the appliance, which generates a negative pressure in the device. If the negative pressure can no longer be built up (damaged sealing tape), the safety pressure cell shuts down the appliance. A message appears in the heat pump manager.

	Unit	Value
Minimum negative pressure	Pa	30

► Replace the sealing tape if required.

In the event of a leak, the fan mixes the refrigerant gas into the air in the room sufficiently.

► Maintain the minimum installation area of the installation room.

Minimum installation area [m ²]	
HPG-I 04 (C)S Premium	HPG-I 12 (C)S Premium
HPG-I 06 (C)S Premium	HPG-I 15 (C)S Premium
HPG-I 08 (C)S Premium	
6.0	8.0

Increasing the minimum installation area

If the minimum installation area requirement cannot be met in the installation room, the installation room can be connected to a neighbouring room via ventilation apertures. The ventilation apertures must be located near the ceiling and the floor. If the ceiling is suspended and there is no wall to the next room, the upper ventilation aperture can be dispensed with.

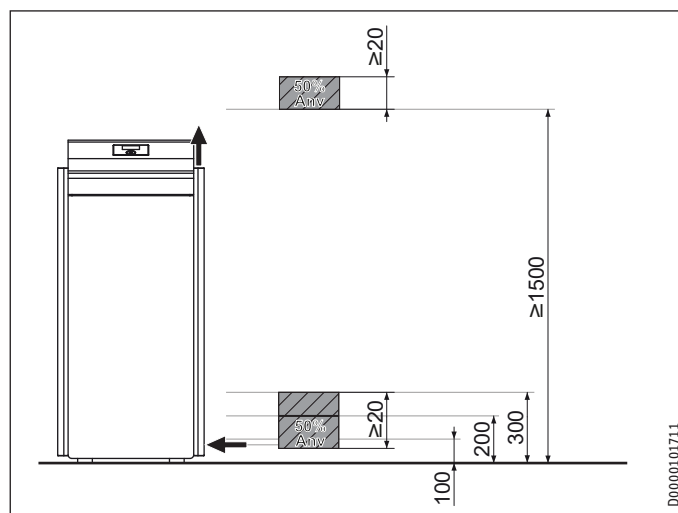

- The ventilation apertures must not be closed.
 - The upper edge of the lower ventilation aperture must be no more than 300 mm above floor level.
 - 50 % of the required ventilation aperture area must be less than 200 mm above floor level.
 - The lower edge of the lower ventilation aperture must be no more than 100 mm above floor level.
 - The ventilation aperture between the rooms must be at least 20 mm wide.
 - A second ventilation aperture is required. The ventilation aperture must be no less than 50 % of the required ventilation aperture area. The lower edge of the ventilation aperture must be at least 1500 mm above floor level.
- Calculate the area of the ventilation apertures.

$$An_v = \frac{m_c - (0,4335 * A)}{50,3}$$

A Room area [m²]

An_v Required aperture surface [m²]

m_c Refrigerant charge [kg]

► Install ventilation apertures corresponding to the calculated area.

8.2 Installation site



Material losses

► Install the appliance only in rooms without a constant ignition source (e.g. open flames, a live gas appliance or an electric heater) or without open flue boilers.



Note

The appliance is designed for indoor installation, except in damp areas.

- Never install the appliance directly below or next to bedrooms.
- Route the pipe outlets through walls and ceilings with structure-borne noise insulation.

INSTALLATION

Preparation

The room in which the appliance is to be installed must meet the following conditions:

- No risk from frost
- The room must not be subject to a risk of explosions arising from dust, gases or vapours.
- When installing the appliance in a boiler room together with other heating equipment, ensure that the operation of other heating equipment will not be impaired.
- The minimum volume of the installation room must be observed (see chapter "Preparation / Safety concept").
- Load bearing floor (for the weight of the appliance, see chapter "Specification / Data table").
- ▶ Ensure that the safety valve for the brine circuit is installed in the installation room. Alternatively, outdoor installation is also possible.
- ▶ Ensure that the substrate is level, even, solid and permanent.
- ▶ For installation on floating screeds, make provisions for quiet heat pump operation.
- ▶ Isolate the installation surface around the heat pump by means of a recess. After completing the installation, seal the recess with a waterproof, sound insulating material, such as silicone.

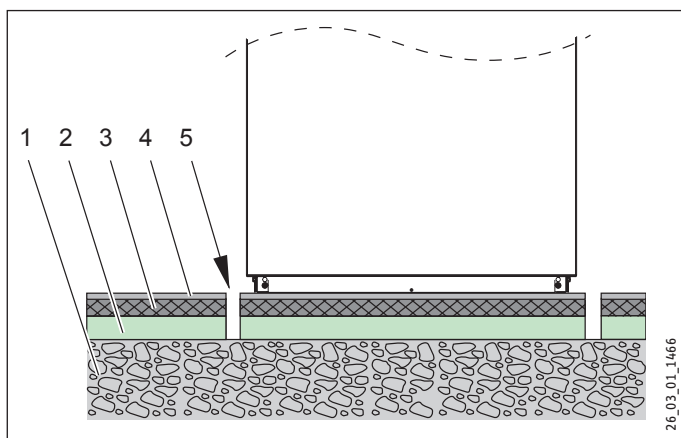

- 1 Concrete base
- 2 Impact sound insulation
- 3 Floating screed
- 4 Floor covering
- 5 Recess

8.3 Minimum clearances

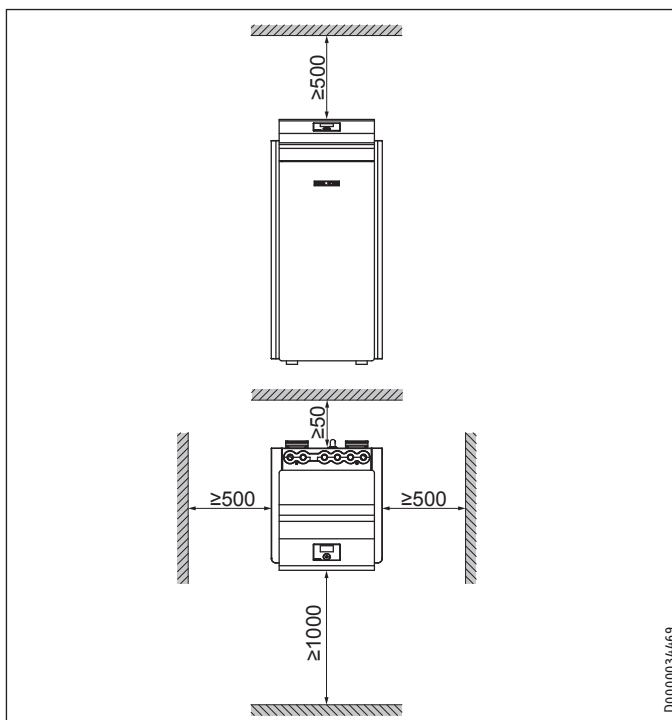

- ▶ Maintain the minimum clearances to ensure trouble-free operation of the appliance and facilitate maintenance work.

8.4 Electrical installation



WARNING Electrocutation

Carry out all electrical connection and installation work in accordance with national and regional regulations.



WARNING Electrocutation

The connection to the power supply must be in the form of a permanent connection. Ensure the appliance can be separated from the power supply by an isolator that disconnects all poles with at least 3 mm contact separation. This requirement can be met by using contactors, circuit breakers, fuses/MCBs, etc.



Material losses

Provide separate fuses/MCBs for the two power circuits, i.e. for the compressor and the electric emergency/booster heater circuits.



Note

The specified voltage must match the mains voltage. Observe the type plate.



Note

The appliance includes an inverter for the variable speed compressor. In the event of an error, inverters can cause DC residual currents. If RCDs are provided, they must be type B AC/DC-sensitive.

A DC residual current can block type A RCDs.

- ▶ Ensure that the appliance power supply is disconnected from the distribution board.

INSTALLATION

Installation

Electrical data is provided in the chapter "Specification / Data table".

- ▶ Use cables with the relevant cross-sections. Observe the applicable national and regional regulations.

HPG-I 04 (C)S Premium | HPG-I 06 (C)S Premium | HPG-I 08 (C)S Premium

Fuse protection	Assignment	Cable cross-section
B 16 A	Compressor	2.5 mm ² for routing through a wall 1.5 mm ² when routing above the surface
B 16 A	Electric emergency/booster heater (BH)	2.5 mm ² 1.5 mm ² with only two live cores and routing on a wall or in an electrical conduit on a wall.
B 16 A	Control unit	1.5 mm ²

HPG-I 12 (C)S Premium | HPG-I 15 (C)S Premium

Fuse protection	Assignment	Cable cross-section
B 25 A	Compressor	4.0 mm ² when routing in a wall ≥2.5 mm ² when routing above the surface
Alternatively: 1x B 16 A further details below table	Compressor	4.0 mm ² when routing in a wall ≥2.5 mm ² when routing above the surface
B 16 A	Electric emergency/booster heater (BH)	2.5 mm ² 1.5 mm ² with only two live cores and routing on a wall or in an electrical conduit on a wall.
B 16 A	Control unit	1.5 mm ²

- ▶ If you have selected a lower fuse protection for the compressor, you will need to limit the maximum power consumption. In the COMMISSIONING / COMPRESSOR menu, adjust the MAXIMUM CURRENT parameter. Observe the information in the commissioning instructions for the heat pump manager.

Heating output with 16 A compressor fuse protection

Source temperature [°C]	Flow temperature [°C]	Heating output [kW]
HPG-I 12 (C)S Premium		
0	35	12.6
0	55	10.2
HPG-I 15 (C)S Premium		
0	35	13.4
0	55	10.2

9. Installation

9.1 Transport

- ▶ Transport the appliance in its packaging to protect it against damage.
- ▶ Protect the appliance against heavy impact during transport.
 - If the appliance needs to be tilted during transport, this must only be for a short time and it must only be tilted on one of its longitudinal sides.
The longer the appliance is tilted, the greater the distribution of refrigerant oil inside the system.
 - Storage and transport at temperatures below - 20 °C and above + 50 °C are not permissible.

9.2 Siting

- ▶ Remove the packaging film and the top and side EPS padding.
- ▶ Tilt the appliance forwards slightly.
- ▶ Place wooden blocks underneath the back of the appliance.
- ▶ Tilt the appliance backwards slightly and lift the appliance off the pallet. To do this, use the handles provided at the back and the front adjustable rubber feet at the bottom.
- ▶ Position the appliance on the prepared substrate.
- ▶ Observe minimum distances (see chapter "Preparations / Minimum clearances").
- ▶ Level the appliance horizontally by adjusting the feet.

9.3 Installing the heat source system



Material losses

The maximum heat source application limit of 40 °C must not be maintained for more than 30 minutes. Continuous operation with a heat source temperature above the maximum application limit (see chapter "Specification / Data table") is not permitted.



Note

Engineer the heat source system for the appliance according to the technical guides.



Note

The appliance can also be operated using groundwater as a heat source. An intermediate circuit is required for operation using groundwater.

- ▶ Fit the GWS groundwater module or a heat exchanger.
- ▶ Fill the intermediate circuit with an ethylene glycol/water mixture with at least 25 % by vol. ethylene glycol. Check for leaks.
- ▶ In the heat pump manager, set the source medium to "WATER". The minimum return source temperature is set automatically to +2 °C.

Permitted brine:

		Part number
MEG 10	Heat transfer medium as concentrate on an ethylene glycol base	231109
MEG 30	Heat transfer medium as concentrate on an ethylene glycol base	161696

9.3.1 Circulation pump and required flow rate

The flow rate is automatically controlled by the heat pump manager. The circulation pump cannot be set manually.

9.3.2 Connection and filling with brine

- ▶ Thoroughly flush the pipework with brine before connecting the heat pump to the heat source circuit. Foreign bodies, such as rust, sand and sealant, can impair the operational reliability of the heat pump. We recommend installing our WPSF brine charging unit in the heat source inlet (see chapter "Appliance description / Accessories").

INSTALLATION

Installation

To facilitate easy connection to the brine circuit, the appliance is supplied with push-fit connectors (see chapter "Installation / Fitting push-fit connectors").

The brine volume of the heat pump under operating conditions can be found in the data table (see chapter "Specification").

The overall volume is equal to the required amount of brine made by mixing undiluted glycol and water. The chloride content of the water must not exceed 100 ppm.

Mixing ratio

The brine concentration varies depending on whether a geothermal collector or a geothermal probe is used as the heat source.

For the mixing ratio see the table below.

	Ethylene glycol	Water
Geothermal probe	25 %	75 %
Geothermal collector	33 %	67 %

Charging the brine circuit



Note

- Insulate the brine lines with diffusion-proof thermal insulation.



Note

- The system fill pressure must be higher than the pre-charge pressure plus the maximum pressure differential of the brine pump.



Note

- For geothermal probes, the diaphragm expansion vessel is suitable for a fill volume of up to 600 l.

The integral diaphragm expansion vessel is opened and sealed at the factory.

- Check the pre-charge pressure (set pressure: 0.5 bar) of the diaphragm expansion vessel on the brine side.
- If necessary, adjust the pre-charge pressure.

The ground source heat pump is equipped with a brine pressure switch in the brine circuit. If there is a leak in the brine circuit, the brine pressure switch shuts down the appliance and prevents brine getting into the ground.

If the pressure in the brine circuit falls below 0.7 bar, the brine pressure switch turns the heat pump off. In order for the heat pump to be enabled again, the pressure must be raised to at least 1.5 bar while the heat pump is on standby.

To prevent the brine pressure switch turning the heat pump off when there is no leak, charge the heat source side of the heat pump during installation with a minimum pressure of > 1.5 bar.

- Charge the system according to the following curve to prevent an unintentional response from the brine pressure switch.

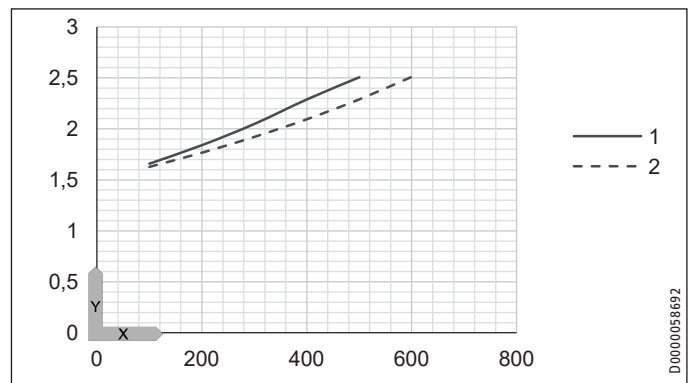

X System volume [l]

Y Charge pressure [bar]

- 1 Required fill pressure depending on system volume at 33 % brine
- 2 Required charge pressure depending on system volume with 25 % brine

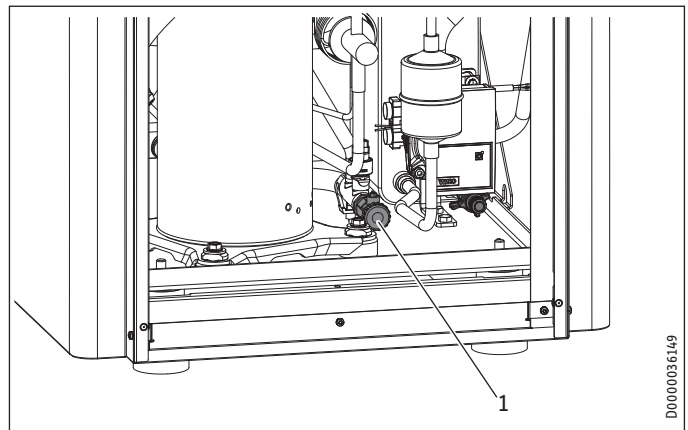

1 Drain, brine side

- Fill the brine circuit via the drain.
- Vent the brine circuit.

To check the brine concentration:

- Determine the density of the glycol/water mixture, e.g. with a hydrometer.

Using the actual density and temperature, you can check the actual concentration in the diagram.



Note

- The quoted output data relates to ethylene glycol (see "Specification").

INSTALLATION

Installation

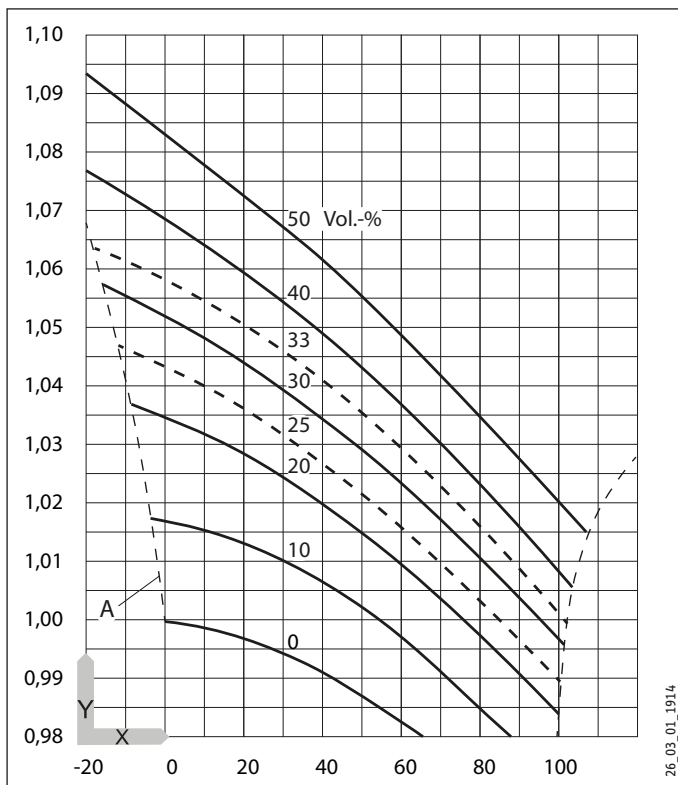

X Temperature [°C]
 Y Density [g/cm³]
 A Frost protection [°C]

- Insulate the brine pipes with diffusion-proof thermal insulation.

9.4 Heating water connection



Note

The use of non-return valves in the charging circuits between the heat generator and the buffer or DHW cylinder can impair the function of the integral multifunction assembly (MFG) and lead to faults in the heating system.

- Only use our standard hydraulic solutions for the installation of the appliances.

The heating system to which the heat pump is connected must be installed by a qualified contractor in accordance with the water installation diagrams that are part of the technical guides.

- Thoroughly flush the pipework before connecting the heat pump. Foreign bodies, such as rust, sand and sealant, can impair the operational reliability of the heat pump. We recommend installing our filter assembly in the heating return (see chapter "Appliance description / Accessories").

To facilitate easy connection to the heating system, the appliance is supplied with push-fit connectors (see chapter "Installation / Fitting push-fit connectors").

- Connect the heating system to the "heating flow" and "heating return" connections. Check for tightness.
- Ensure that the heating flow and return are connected correctly.
- When sizing the heating circuit, observe the maximum available external pressure differential (see chapter "Specification / Data table").

- Provide thermal insulation in accordance with applicable regulations.

The diaphragm expansion vessel on the heating side is opened and sealed at the cap valve at the factory.

Safety valve

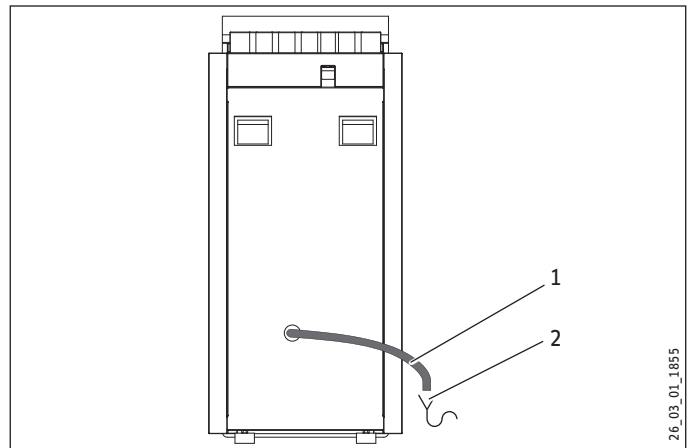

- 1 Procedure
- 2 Drain

- Size the discharge outlet so that water can drain off unimpeded when the safety valve is fully opened.
- Ensure that the safety valve drain is open to the outside.
- Install the safety valve drain with a constant fall to the discharge outlet. When installing the drain, never kink the drain hose.

9.5 Oxygen diffusion



Material losses

Do not use open vented heating systems. Use oxygen diffusion-proof pipes in underfloor heating systems with plastic pipework.

In underfloor heating systems with plastic pipes that are permeable to oxygen and in open vented heating systems, oxygen diffusion may lead to corrosion on the steel components of the heating system (e.g. on the indirect coil of the DHW cylinder, on buffer cylinders, steel radiators or steel pipes).

- With heating systems that are permeable to oxygen, separate the heating system between the heating circuit and the buffer cylinder.



Material losses

The products of corrosion (e.g. rusty sludge) can settle in the heating system components, which may result in a lower output or fault shutdowns due to reduced cross-sections.

INSTALLATION

Installation

9.6 Filling the heating system

Heating water quality

Carry out a fill water analysis before filling the system. This analysis may, for example, be requested from the relevant water supply utility.



Material losses

To avoid damage as a result of scaling, it may be necessary to soften or desalinate the fill water. The fill water limits specified in chapter "Specification / Data table" must always be observed.

- ▶ Recheck these limits 8-12 weeks after commissioning and as part of the annual system maintenance.



Note

With a conductivity > 1000 µS/cm, desalination treatment is recommended in order to avoid corrosion.



Note

Suitable appliances for water softening and desalinating, as well as for filling and flushing heating systems, can be obtained from trade suppliers.



Note

If you treat the fill water with inhibitors or additives, the same limits apply as for desalination.

Filling the heating system



Material losses

- ▶ Never switch on the power before filling the system.



Material losses

High flow rates or water hammer can damage the appliance.

- ▶ Fill the appliance at a low flow rate.

In the delivered condition, the diverter valve of the MFG is positioned at the centre. This ensures the heating and DHW circuits are filled equally. If the power is switched on, the diverter valve automatically moves into the central heating position.

If you intend to fill or drain the system later, first return the diverter valve to its centre position.

- ▶ Activate the parameter.

Parameter

DRAIN HYD (DIAGNOSIS /.RELAY TEST SYSTEM)

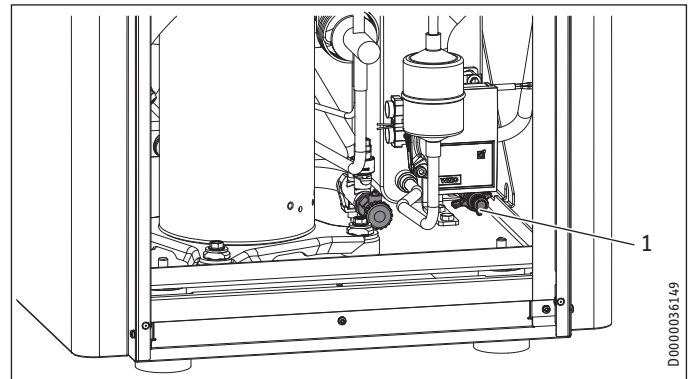

1 Drain, heating side

- ▶ Fill the heating system via the drain. Refer to the section "Determining fill pressure".

Determining the fill pressure

The diaphragm expansion vessel installed in the appliance has a volume of 24 litres. The pre-charge pressure P_0 is 1.5 bar.

If the height difference Δh between the highest point of the heating system and the diaphragm expansion vessel is no more than 13 m, the diaphragm expansion vessel can be used without any changes being required.

- ▶ Fill the heating system to a pressure of at least 1.8 bar ($P_0 + 0.3$ bar). Observe the safety valve's response pressure of 3 bar.

If the height difference between the highest point of the heating system and the diaphragm expansion vessel is more than 13 m, the pre-charge pressure needs to be adapted.

- ▶ Calculate the pre-charge pressure:

$$P_0 = \frac{\Delta h}{10} + 0,2 \text{ bar}$$

D.0000081230

- ▶ Note that the heating system fill pressure increases accordingly.
- ▶ Check whether a further external diaphragm expansion vessel needs to be installed.
- ▶ Fill the heating system to the appropriate pressure ($P_0 + 0.3$ bar). Observe the safety valve's response pressure of 3 bar.

INSTALLATION

Installation

9.7 Venting the heating system

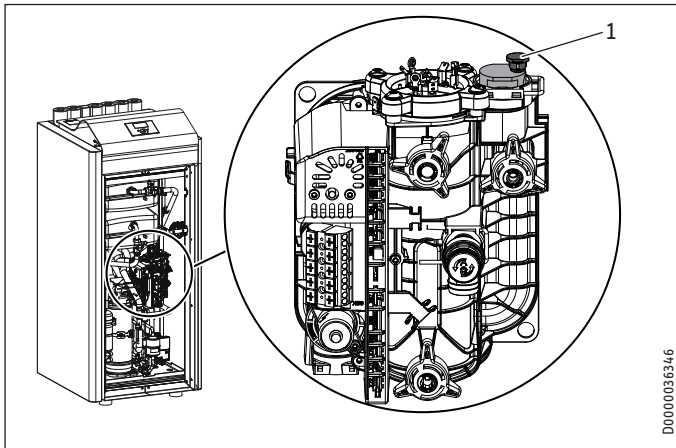

1 Automatic air vent valve

- ▶ Vent the pipework by pulling up the red cap on the air vent valve.
- ▶ Close the air vent valve after the venting process.

9.8 DHW heating

For DHW heating, a DHW cylinder with an internal indirect coil is required.

- ▶ Select the indirect coil surface area to match the DHW output of the heat pump. For a DHW output of 6-8 kW we recommend an indirect coil surface area of at least 2 m².

An integral 3-way valve is integrated in the appliance for switching between the DHW heating circuit and the central heating circuit.

- ▶ Thoroughly flush the pipework before connecting the heat pump. Foreign bodies, such as rust, sand and sealant, can impair the operational reliability of the heat pump. We recommend installing our filter assembly in the DHW heating circuit (see chapter "Appliance description / Accessories").
- ▶ Connect the DHW flow of the appliance to the upper heat exchanger coil connection of the DHW cylinder (see "Specification / Dimensions and connections").
- ▶ Connect the DHW return of the appliance to the lower heat exchanger coil connection of the DHW cylinder (see "Specification / Dimensions and connections").



Note

If no DHW heating is being connected, connections e22 (cylinder flow) and e23 (cylinder return) are to be hydraulically interconnected.

9.9 Operation with buffer cylinder

- ▶ Install the supplied TAF PT immersion/contact sensor.
- ▶ Connect the sensor to the heat pump manager.
- ▶ Set the parameter on the heat pump manager.

Parameter	Setting
BUFFER OPERATION (SETTINGS / HEATING / STANDARD ON SETTINGS)	ON

HPG-I CS Premium

For cooling in combination with a buffer cylinder, an additional TAF PT immersion / contact sensor is required.

- ▶ Install the sensor in the buffer cylinder flow.
- ▶ Connect the sensor to the heat pump manager.

9.10 Fitting the push-fit connectors



Note

The plastic push-fit connectors are not suitable for installation in the DHW line.

- ▶ Only install the push-fit connectors in the heating or brine circuits.



Material losses

- ▶ Tighten the screw cap of the push-fit connector by hand. Never use a tool.



Material losses

To ensure the push-fit connector is held securely, pipes with a surface hardness > 225 HV (e.g. stainless steel) must have a groove.

- ▶ Using a pipe cutter, cut a groove (depth approx. 0.1 mm) at a defined distance from the end of the pipe.
 - Pipe diameter 22 mm: 17±0.5 mm
 - Pipe diameter 28 mm: 21±0.5 mm



Material losses

Support sleeves are required when using plastic pipes.

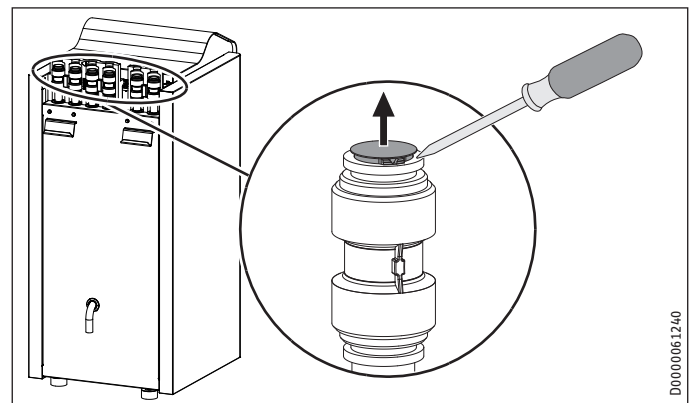

- ▶ Remove the protective grey caps from the push-fit connectors.

How the push-fit connectors work

The push-fit connectors are equipped with a retainer with stainless steel serrations and an O-ring for sealing. In addition, the push-fit connectors are equipped with the "twist and lock" function. Simply turning the screw cap by hand will secure the pipe in the connector and push the O-ring against the pipe to seal it.

Making the push-fit connection

The connector must be in its relaxed position before the pipe is inserted. In this position, there is a small gap between the screw cap and main body.

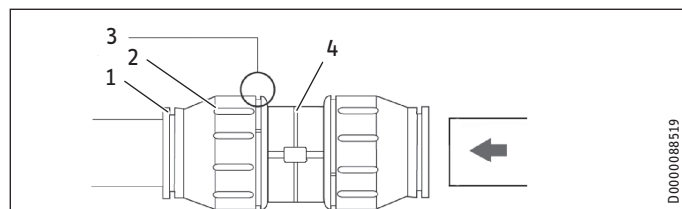

- 1 Retainer
- 2 Screw cap
- 3 Gap between screw cap and main body
- 4 Main body

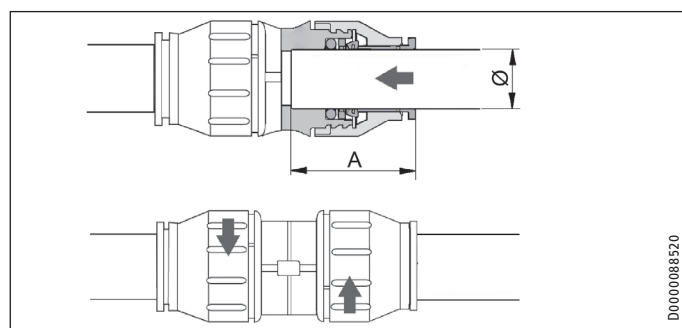

Pipe Ø 28 mm
Depth of insertion A max. 44 mm

Material losses

- ! Pipe ends must be deburred.
- ▶ Always use a pipe cutter to trim pipes.

- ▶ Push the pipe past the O-ring into the push-fit connector until it reaches the prescribed insertion depth.
- ▶ Finger-tighten the screw cap as far as it will go against main body. This secures the push-fit connection.

Undoing the push-fit connection

If the push-fit connectors later need to be undone, proceed as follows:

- ▶ Turn the screw cap anti-clockwise until there is a narrow gap of approx. 2 mm. Press the retainer back with your fingers and hold on to it.
- ▶ Pull out the inserted pipe.

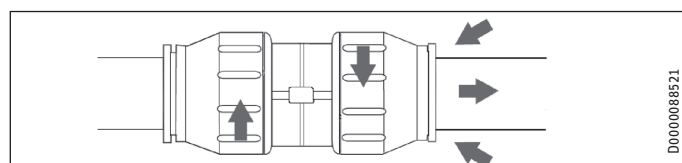

10. Electrical connection

10.1 General



WARNING Electrocutation

- ▶ Before working on the appliance, isolate it from the power supply at the control panel.



Note

- The leakage current of this appliance can be > 3.5 mA.



Note

- In conjunction with the WPM heat pump manager, use the HSM mixer servomotor.

Connection work must only be carried out by a qualified contractor and in accordance with these instructions.

You must have permission to connect the appliance from the relevant power supply utility (PSU).

- ▶ See chapter "Preparation / Electrical installation".

10.2 Electrical connection



Note

- ▶ Fill the heating system before making the electrical connection (see chapter "Installation / Heating water connection").

Terminals are located at the appliance control panel under the top cover.

For all connections, use appropriate cables in accordance with local regulations.

- ▶ Remove the cover (see chapter "Troubleshooting / Removing the casing parts").
- ▶ Remove the rear thermal insulation piece.
- ▶ Route the cables through the cable entry in the front thermal insulation piece.
- ▶ Then route the electrical cables through the strain relief fittings.
- ▶ Check that the strain relief fittings are working as intended.
- ▶ Route all connecting cables and sensor leads through the entry provided in the back panel.

10.2.1 Compressor and electric emergency/booster heater

Appliance function	Effect of the electric emergency/booster heater
Mono energetic operation	If the dual mode point is undershot, the electric emergency/booster heater safeguards both the heating operation and the provision of high DHW temperatures.
Emergency mode	If the heat pump shuts down due to a fault, the heating output is covered by the electric emergency/booster heater.

You can choose between two connection options. The compressor connection remains single-phase.

Connection option	Connection type
A	separate connections for compressor and emergency/booster heater
B	connection for compressor and emergency/booster heater using a 5-core cable

INSTALLATION

Commissioning

Mains voltage			
X2.2	L' (power supply utility input) L* (pumps L)	L' L* (pumps L)	L' (power supply utility input) L* (pumps L)
X2.3	L N PE	L N ⊕ PE	Heating circuit pump 1
X2.4	L N PE	L N ⊕ PE	Heating circuit pump 2
X2.5	L N PE	L N ⊕ PE	Heating circuit pump 3
X2.6	L N PE	L N ⊕ PE	Buffer charging pump 1
X2.7	L N PE	L N ⊕ PE	Buffer charging pump 2
X2.8	L N PE	L N ⊕ PE	DHW charging pump
X2.9	L N PE	L N ⊕ PE	Source pump / defrost
X2.10	L N PE	L N ⊕ PE	Fault output
X2.11	L N PE	L N ⊕ PE	DHW circulation pump / 2nd heat source DHW
X2.12	L N PE	L N ⊕ PE	2nd heat source heating
X2.13	L N PE	L N ⊕ PE	Cooling
X2.14	Mixer OPEN N PE Mixer CLOSE	▲ N ⊕ PE ▼	Mixer, heating circuit 2 (X2.14.1 Mixer OPEN X2.14.2 Mixer CLOSE)
X2.15	Mixer OPEN N PE Mixer CLOSE	▲ N ⊕ PE ▼	Mixer heating circuit 3 (X2.15.1 Mixer OPEN X2.15.2 Mixer CLOSE)



Note

For every appliance fault, output X2.10 issues a 230 V signal.

In the case of temporary faults, the output switches the signal through for a specific time.

In the case of faults that result in a permanent appliance shutdown, the output switches through permanently.

- You can define the characteristics of the output via parameter "COMMISSIONING / I/O CONFIGURATION / OUTPUT X 2.10".

10.3 High limit safety cut-out for area heating system



Material losses

In order to prevent excessively high flow temperatures in the area heating system causing damage in the event of a fault, install a high limit safety cut-out to limit the system temperature.

10.4 Sensor installation

- When installing a sensor, follow the commissioning instructions for the heat pump manager (see chapter "Connecting external components").

11. Commissioning

Only a qualified contractor may adjust the settings in the commissioning instructions for the heat pump manager, commission the appliance and instruct the operator in its use.

Carry out commissioning in accordance with these operating and installation instructions, and the instructions for the heat pump manager. Our customer support can assist with commissioning, which is a chargeable service.

If this appliance is intended for commercial use, observe the rules of the relevant Health & Safety at Work Act during commissioning. For further details, check with your local authorising body (e.g. TÜV).

11.1 Checks before commissioning

- Before commissioning check the points detailed below.

11.1.1 Heating system

- Have you filled the heating system to the correct pressure?
- Have you closed the automatic air vent valve of the multi-function assembly (MFG) after venting?



Material losses

- Observe the maximum system temperature in underfloor heating systems.

11.1.2 Heat source



Material losses

If screed drying is carried out with a ground source heat pump, the heat source can be overloaded, especially a geothermal probe. The ground around the geothermal probe may freeze in the process. Heat transfer to the ground will be irreparably damaged.

- Observe the chapter "Menu structure / PROGRAMS menu / HEAT-UP PROGRAM" in the commissioning instructions for the heat pump manager.

The appliance is equipped with a source protection function. If the temperature falls below a defined brine temperature, the appliance automatically reduces the power.

11.1.3 Temperature sensors

- Have you correctly positioned and connected the outside temperature sensor and the immersion/contact sensor (in conjunction with a buffer cylinder)?

11.1.4 High limit safety cut-out

At ambient temperatures below -15 °C, the high limit safety cut-out of the multifunction assembly may respond.

- Check whether the high limit safety cut-out has tripped.

INSTALLATION

Commissioning

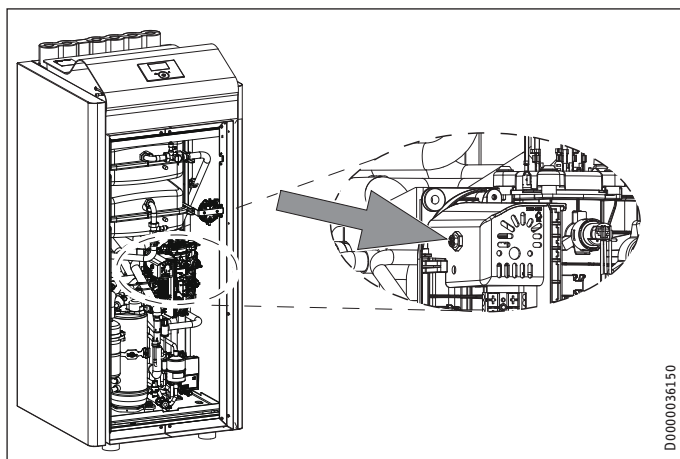

- ▶ Reset the high limit safety cut-out by pressing the reset button.

11.1.5 Power supply

- Have you correctly connected the power supply?

11.2 Initial start-up

11.2.1 Activating spread control



Note

- ▶ For cooling, use the constant flow rate (default setting).

- ▶ To adapt the appliance to your requirements, activate spread control.

Parameter	Setting
SPREAD CONTROL (COMMISSIONING / CHARGING PUMP CONTROL / HEATING / TYPE OF CONTROL)	ON
SPREAD CONTROL (COMMISSIONING / CHARGING PUMP CONTROL / DHW / TYPE OF CONTROL)	ON

For spread control we recommend the following settings.

Parameter	Setting [K]
SPREAD (COMMISSIONING / CHARGING PUMP CONTROL / HEATING / SET POINTS)	8
SPREAD (COMMISSIONING / CHARGING PUMP CONTROL / DHW / SET POINTS)	8

11.2.2 Heating curve adjustment

The efficiency of a heat pump decreases as the flow temperature rises. Adjust the heating curve carefully. Heating curves that are set too high cause the zone valves or thermostatic valves to close, which may result in the minimum required flow rate in the heating circuit being undershot.

- ▶ Observe the WPM commissioning instructions.

The following steps will help you to adjust the heating curve correctly:

- ▶ Fully open thermostatic or zone valves in a lead room (e.g. living room or bathroom).
We do not recommend installing thermostatic or zone valves in the lead room. Control the temperature for these rooms via a remote control.

- ▶ At different outside temperatures (e.g. -10 °C and +10 °C), adjust the heating curve so that the required temperature is set in the lead room.

Standard values to begin with:

Parameter	Underfloor heating	Radiator heating system
Heating curve	0.4	0.8
Control dynamic	100	100
Comfort temperature	20 °C	20 °C

- ▶ If the room temperature in spring and autumn is too low (approx. 10 °C outside temperature), raise the comfort temperature.

Parameter
COMFORT TEMPERATURE (SETTINGS / HEATING / HEATING CIRCUIT)



Note

- ▶ If no remote control is installed, raising the comfort temperature leads to a parallel offset of the heating curve.

- ▶ If the room temperature is not high enough at low outside temperatures, increase the heating curve.

Parameter
HEATING CURVE RISE (SETTINGS / HEATING / HEATING CIRCUIT)

- ▶ If the heating curve has been raised and no remote control has been installed in the lead room, adjust the zone valve or thermostatic valve in the lead room to the required temperature when outside temperatures are high.



Note

- ▶ Never reduce the temperature in the entire building by closing all zone or thermostatic valves; instead use the setback programs.

- ▶ Once everything has been implemented correctly, the system can be heated to its maximum operating temperature and vented once again.



Material losses

- ▶ For underfloor heating systems, observe the maximum permissible temperature for that particular underfloor heating.

11.2.3 Other settings

- ▶ For additional settings, note the information in the WPM commissioning instructions.

Parameter
BUFFER OPERATION (SETTINGS / HEATING / STANDARD SETTING)
WW OUTPUT SUMMER (SETTINGS / DHW / STANDARD SETTING)
WW OUTPUT WINTER (SETTINGS / DHW / STANDARD SETTING)
COOLING (SETTINGS)

12. Appliance handover

Explain the appliance function to users and familiarise them with how it works.



Note

- ▶ Hand over these operating and installation instructions to the user for safe-keeping. All information in these instructions must be closely observed. The instructions provide information on safety, operation, installation and maintenance of the appliance.

13. Appliance shutdown



Material losses

- ▶ Never interrupt the heat pump power supply, even outside of the heating season. Otherwise, system frost protection is not guaranteed. The heat pump manager automatically switches the heat pump to summer or winter mode.



Material losses

- ▶ Observe the temperature application limits and the minimum circulation volume on the heat consumer side (see chapter "Specification / Data table").

13.1 Standby mode

To shut the system down, simply set the heat pump manager to "Standby mode". This way, the safety functions that protect the system remain enabled, e.g. frost protection.

13.2 Power interruption

If the system is to be isolated from the power supply permanently, please observe the following:



Material losses

- ▶ If the heat pump is completely switched OFF and there is a risk of frost, drain the system on the water side.

14. Troubleshooting



WARNING Electrocutation

- ▶ Before working on the appliance, isolate it from the power supply at the terminal area. Following disconnection from the power supply, parts of the appliance may remain energised for 5 minutes until the inverter capacitors have discharged.



Note

- ▶ Please observe the instructions for the heat pump manager.



Note

- ▶ The following inspection instructions may only be carried out by a qualified contractor.



Note

- ▶ When you open the appliance, check the sealing tape. The sealing tape is required for generating the necessary negative pressure.
 - ▶ Replace the sealing tape if required.



Note

- ▶ The built-in fan must generate a negative pressure of at least 30 Pa.
 - ▶ Check the negative pressure with a barometer on the back of the appliance.

14.1 Removing the casing parts



Note

- ▶ When you open the appliance, check the sealing tape. The sealing tape is required for generating the necessary negative pressure.
 - ▶ Replace the sealing tape if required.

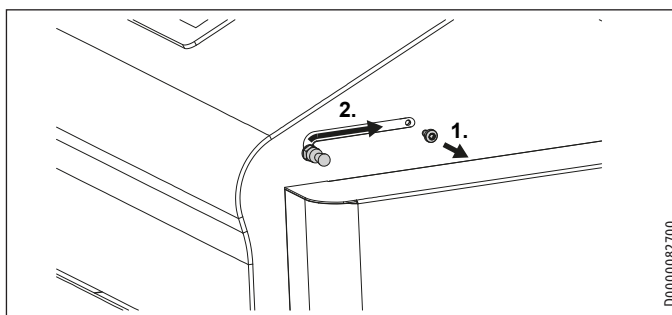

- ▶ Remove the screws on both sides of the appliance.
- ▶ Slide the handles on both sides of the appliance along the guide as far as they will go.

Removing the cover

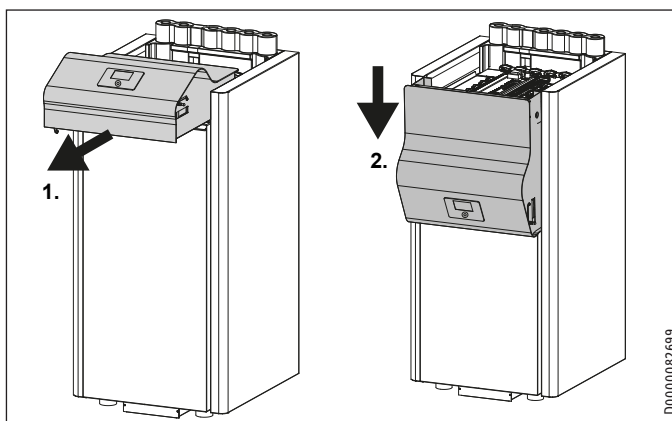

- ▶ Pull the cover forwards.
- ▶ Hang the cover down in front of the appliance.

INSTALLATION

Troubleshooting

Removing the front panel

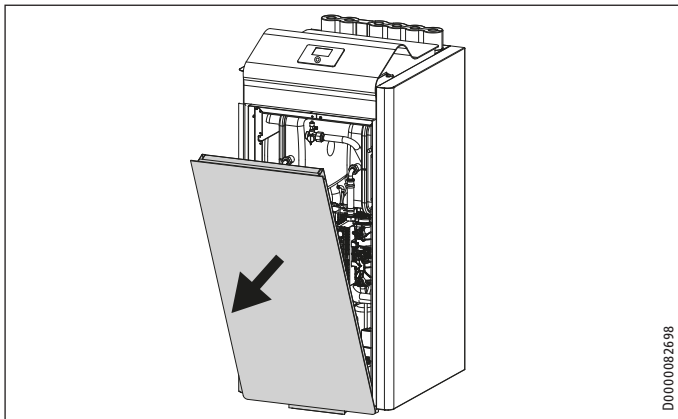

D0000082698

- ▶ Remove the front panel by pulling it towards the front.

Removing the side casing

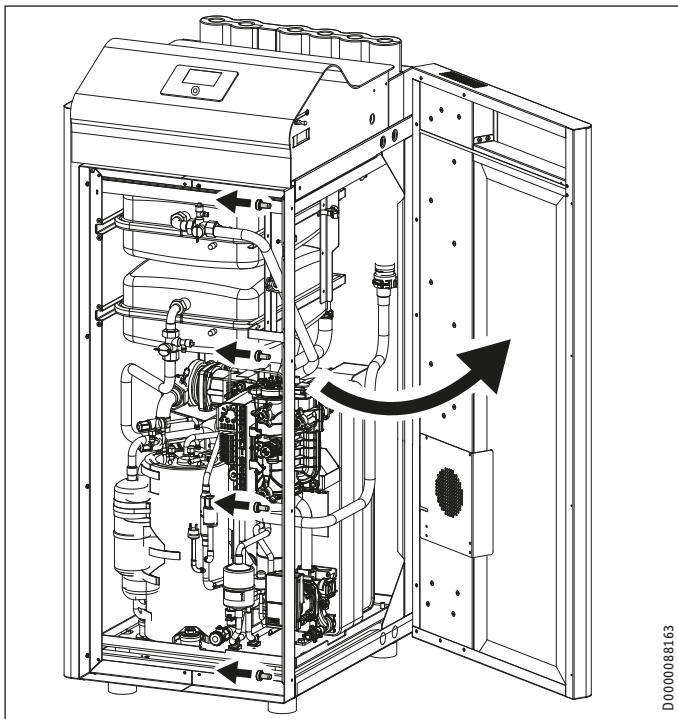

D0000088163

- ▶ Remove the front panel (see “Removing the front panel”).
- ▶ Remove the screws.
- ▶ Pivot the side casing to the side.
- ▶ If necessary, lift the side casing out of the rear hinges. Pay attention to any electrical cables.

14.2 Resetting the high limit safety cut-out

If the heating water temperature exceeds 75 °C, the electric emergency/booster heater shuts down.

If the electric emergency/booster heater does not switch off, the high limit safety cut-out responds at a heating water temperature of 89 °C.

- ▶ Remove the cause of the fault.

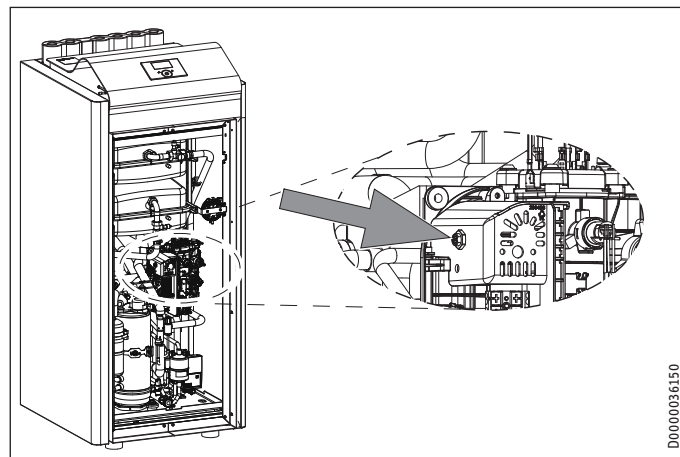

D0000036150

- ▶ Reset the high limit safety cut-out by pressing the reset button. If necessary, use a pointed object to do this.
- ▶ Check whether the heating water is being circulated at a sufficiently high flow rate.

14.3 Resetting the compressor tempering device

If the hot gas temperature exceeds 120 °C, the compressor shuts down.

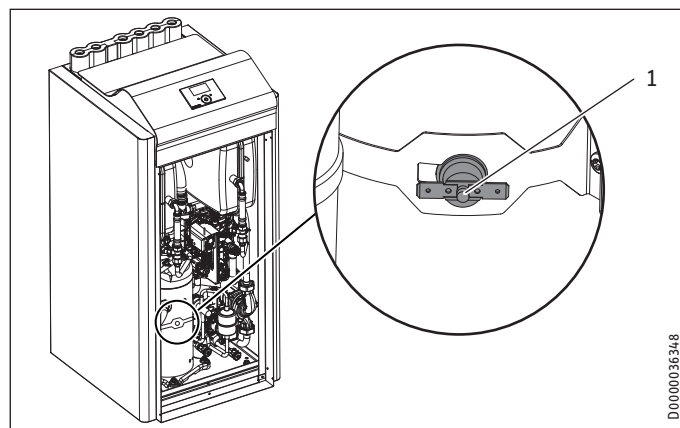

D0000036348

- 1 tempering device reset button
- ▶ Isolate the appliance from the power supply.
- ▶ Remove the cause of the fault.



Note

- ▶ Do not reset the high limit safety cut-out at temperatures above 65 °C.

- ▶ Reset the high limit safety cut-out by pressing the reset button.

INSTALLATION

Troubleshooting

14.4 Checking the IWS DIP switch settings

If the fault cannot be located during a service using the heat pump manager, open the control panel in emergencies and check the IWS settings.

- ▶ Remove the cover (see chapter “Troubleshooting / Removing the casing parts”).

IWS

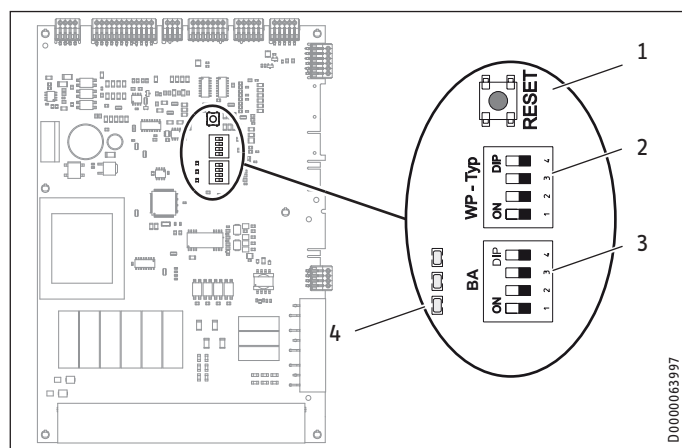

- 1 Reset button
- 2 DIP switch (WP-Typ)
- 3 DIP switch (BA)
- 4 LEDs

DIP switch (WP-Typ)

The DIP switch (WP-Typ) on the IWS serves to set the relevant heat pump type.

Factory setting

Compressor mode with electric emergency/booster heater

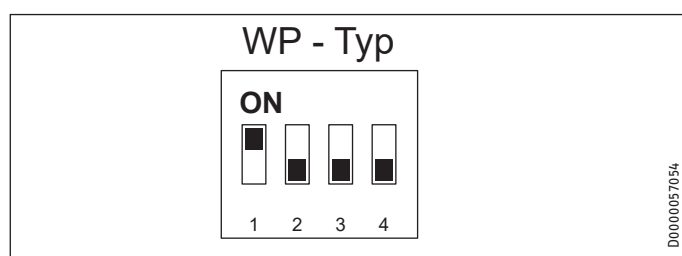

- ▶ Check whether the DIP switch is set correctly.

Compressor mode with an external second heat generator

! **Material losses**
In this case, do not connect the electric emergency/booster heater.

If the appliance is operated in dual mode with an external second heat generator, set the DIP switch as follows.

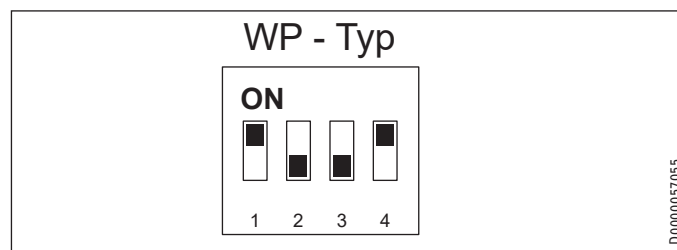

DIP switch (BA)

- ▶ Check whether the DIP switch (BA) is set correctly.

Heating and cooling operation

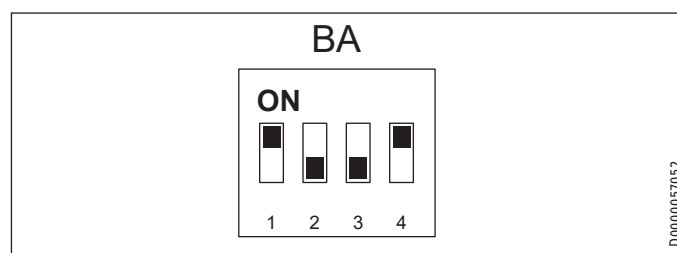

14.5 LEDs (IWS)

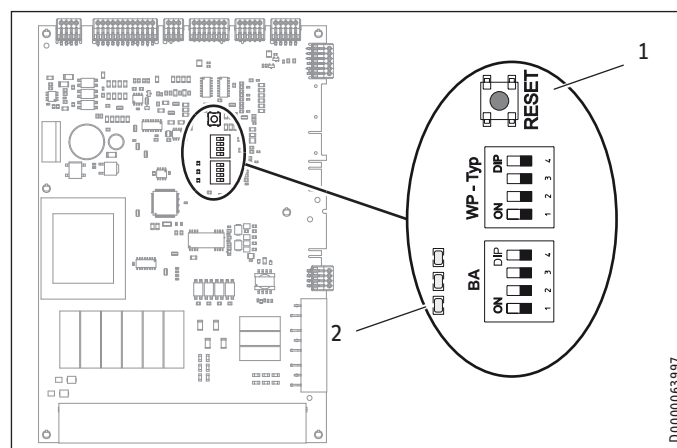

- 1 Reset button
- 2 LEDs

The following table shows the meaning of the LEDs on the IWS.

LED indicator	Meaning
Red LED flashes	Single fault. The appliance shuts down. The appliance restarts after 10 minutes. The LED goes off.
Red LED illuminates	Multiple faults have occurred. The appliance shuts down. The appliance only restarts following a reset on the IWS. This also resets the internal fault counter. The appliance can be restarted after 10 minutes. The LED goes off.
Green LED (centre) flashes	The heat pump is initialising.
Green LED (centre) illuminates	The heat pump was initialised successfully and the connection with the WPM is active.

Faults indicated by the red LED:

- High pressure fault
- Low pressure fault
- Central fault
- Hardware fault on the IWS

14.6 Reset button

If the IWS was incorrectly initialised, you can reset the settings with this button.

- ▶ For this, also observe chapter "Reset options" in the heat pump manager commissioning instructions.

15. Maintenance



WARNING Electrocutation

- ▶ Prior to commencing any service or cleaning work, isolate the appliance across all poles from the power supply.

Following disconnection from the power supply, parts of the appliance may remain energised for 5 minutes until the inverter capacitors have discharged.



Note

When you open the appliance, check the sealing tape. The sealing tape is required for generating the necessary negative pressure.

- ▶ Replace the sealing tape if required.

We recommend a regular inspection (to establish the current condition of the system), and maintenance if required (to return the system to its original condition).

- ▶ Check the discharge aperture on the top of the appliance and the intake aperture on the side of the appliance (visual check). Remove any contaminants and blockages immediately.

16. Specification

16.1 Dimensions and connections

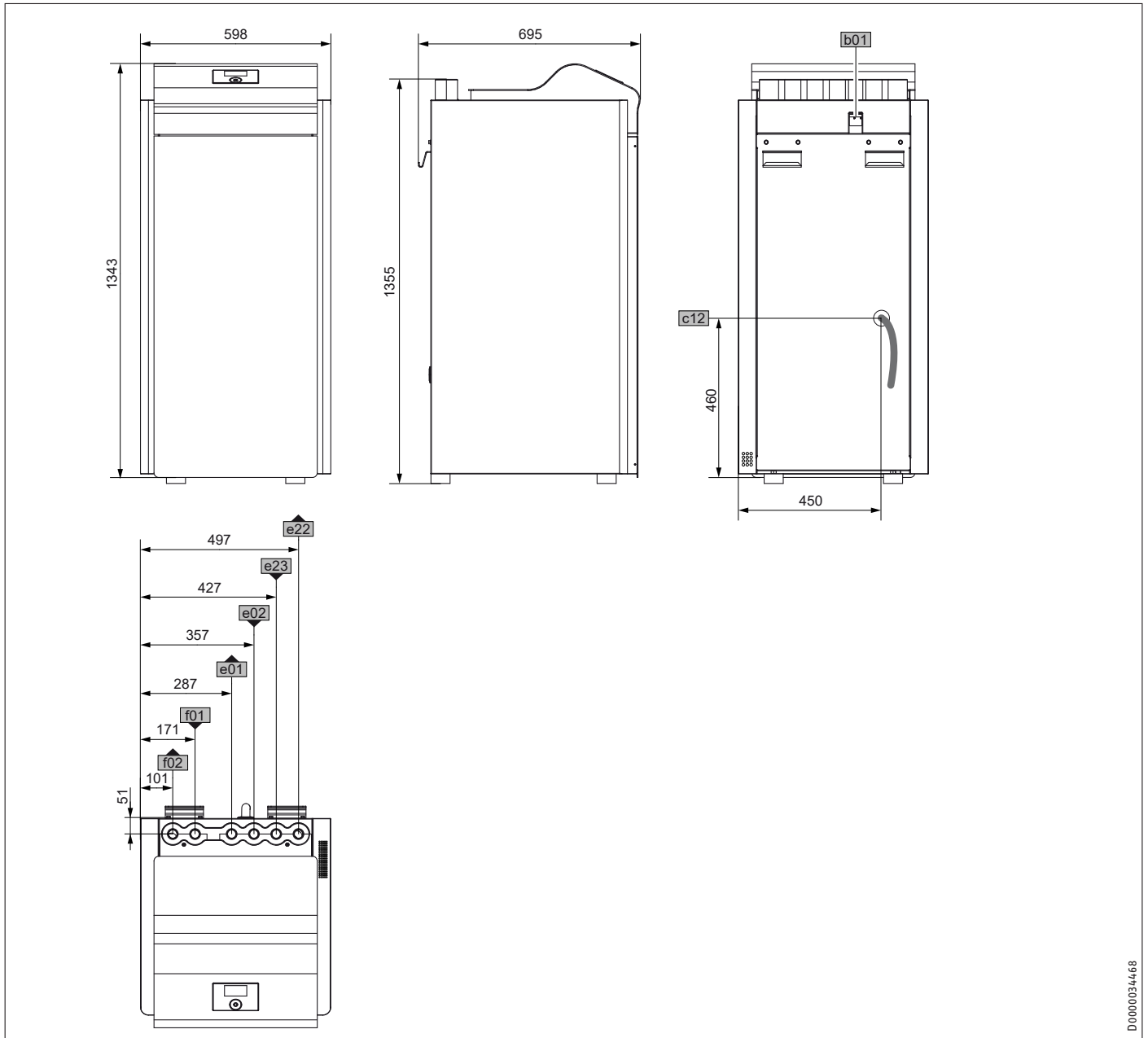

D0000034468

INSTALLATION

Specification

			HPG-I 04 S Pre- mium	HPG-I 06 S Pre- mium	HPG-I 08 S Pre- mium	HPG-I 12 S Pre- mium	HPG-I 15 S Pre- mium
b01	Entry electrical cables						
c12	Safety valve drain	Diameter	mm	22	22	22	22
e01	Heating flow	Diameter	mm	28	28	28	28
e02	Heating return	Diameter	mm	28	28	28	28
e22	Cylinder flow	Diameter	mm	28	28	28	28
e23	Cylinder return	Diameter	mm	28	28	28	28
f01	Heat source flow	Diameter	mm	28	28	28	28
f02	Heat source return	Diameter	mm	28	28	28	28

			HPG-I 04 CS Pre- mium	HPG-I 06 CS Pre- mium	HPG-I 08 CS Pre- mium	HPG-I 12 CS Pre- mium	HPG-I 15 CS Pre- mium
b01	Entry electrical cables						
c12	Safety valve drain	Diameter	mm	22	22	22	22
e01	Heating flow	Diameter	mm	28	28	28	28
e02	Heating return	Diameter	mm	28	28	28	28
e22	Cylinder flow	Diameter	mm	28	28	28	28
e23	Cylinder return	Diameter	mm	28	28	28	28
f01	Heat source flow	Diameter	mm	28	28	28	28
f02	Heat source return	Diameter	mm	28	28	28	28

INSTALLATION Specification

16.2 Wiring diagram

HPG-I 04 (C)S Premium | HPG-I 06 (C)S Premium | HPG-I 08 (C)S Premium

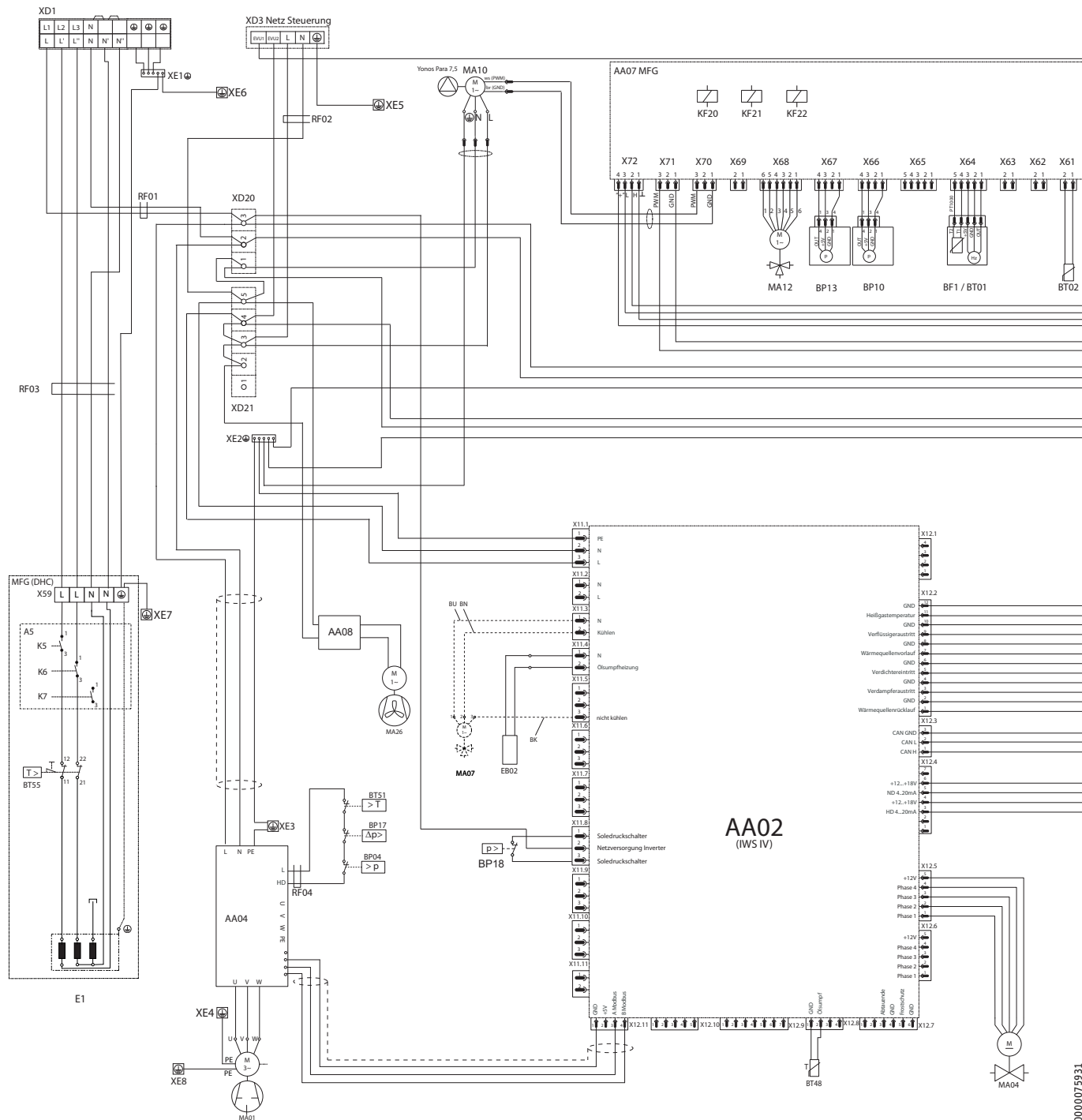

D0000075931

INSTALLATION Specification

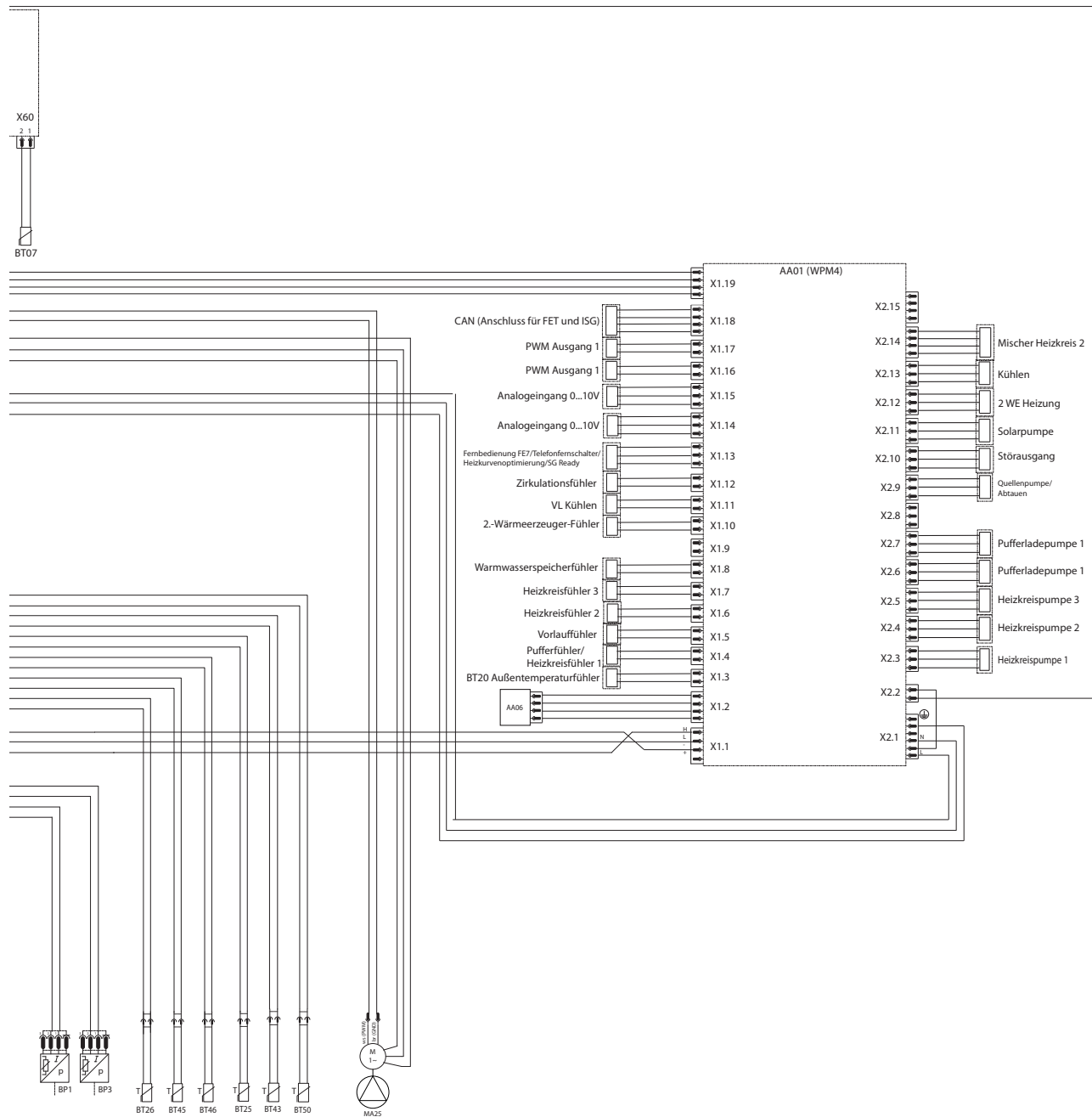

D0000075931

INSTALLATION

Specification

Key	
AA01	Heat pump manager (WPM)
AA02	Integral heat pump control unit (IWS)
AA04	Inverter compressor
AA06	Programming unit
AA07	Multifunction assembly MFG 3.2
AA08	Fan power supply unit
BF1	Flow sensor, heating
BL01	Float switch
BP1	High pressure sensor (34 bar)
BP3	Low pressure sensor (16 bar)
BP4	High pressure switch (34 bar)
BP10	Heating circuit pressure sensor
BP13	Heat source pressure sensor
BP17	Internal negative pressure barometric cell
BP18	Heat source pressure switch
BT01	Heating flow temperature sensor - Pt1000
BT02	Heating return temperature sensor - Pt1000
BT04	Temperature sensor, DHW cylinder
BT07	Heating flow temperature sensor, multifunction assembly MFG - Pt1000
BT20	Outdoor air temperature sensor - Pt1000
BT25	Heat source flow temperature sensor - Pt1000
BT26	Heat source return temperature sensor - Pt1000
BT43	Condenser outlet temperature sensor - Pt1000
BT45	Temperature sensor, evaporator discharge
BT46	Compressor intake temperature sensor - Pt1000
BT48	Oil sump temperature sensor - Pt1000
BT50	Hot gas temperature sensor - Pt1000
BT51	Temperature switch, compressor housing
BT55	High limit safety cut-out MFG
EB02	Oil sump heater
K20	Relay, instantaneous water heater
K21	Relay, instantaneous water heater
K22	Relay, instantaneous water heater
KF06	Contacteur
KF20	Emergency/booster heater relay, multifunction assembly MFG
KF21	Emergency/booster heater relay, multifunction assembly MFG
KF22	Emergency/booster heater relay, multifunction assembly MFG
MA01	Compressor motor
MA04	Electrical expansion valve stepper motor
MA07	Heating/cooling diverter valve motor
MA10	Circulation pump
MA12	DHW heating diverter valve motor
MA25	Heat source pump motor
MA26	Suction fan
RF01	Snap-on ferrite bead, compressor cable
RF02	Snap-on ferrite bead, control voltage
RF03	Snap-on ferrite bead, emergency/booster heater cable
RF04	Snap-on ferrite bead, safety cable
XD1	Terminal, external emergency/booster heater, HP power supply
XD3	External control terminal
XD20	Distribution terminal
XD21	Distribution terminal
XE1	Earth block
XE2	Earth block
XE3	Earth stud, inverter panel
XE4	Earth stud, inverter cooling
XE5	Earth stud, WPM panel
XE6	Earth stud, programming unit panel
XE7	Earth stud, front panel
XE8	Earth stud, oscillation plate
X1.1	WPM CAN IWS
X1.2	WPM CAN programming unit
X1.3	WPM outside temperature sensor
X1.4	WPM buffer cylinder / HC 1
X1.6	WPM HC 2
X1.8	WPM DHW sensor
X1.10	WPM 2nd heat generator sensor
X1.11	WPM flow, cooling
X1.12	WPM DHW, bottom
X1.14	WPM analogue input 0-10 V
X1.15	WPM analogue input 0-10 V
X1.16	WPM solar circuit pump PWM
X1.17	WPM 2nd heat generator PWM
X1.19	WPM CAN MFG
X2.1	WPM power supply
X2.2	WPM power-OFF
X2.3	WPM HC pump 1
X2.4	WPM mixer pump 1 / HC pump 2
X2.10	WPM fault output
X2.11	WPM solar circuit pump
X2.14	WPM mixer 1
X11.1	3-pin IWS plug - power supply control
X11.3	2-pin IWS plug - defrost valve
X11.4	2-pin IWS plug - oil sump heater
X11.8	3-pin IWS plug - power-OFF
X12.1	4-pin IWS Rast plug - fan PWM
X12.2	12-pin IWS Rast plug - temperature sensor 1
X12.3	3-pin IWS Rast plug - BUS connection
X12.4	7-pin IWS Rast plug - high/low pressure
X12.5	5-pin IWS Rast plug - expansion valve
X12.6	5-pin IWS Rast plug - inverter cooling valve
X12.7	6-pin IWS Rast plug - temperature sensor 2
X12.9	7-pin IWS Rast plug - air differential pressure sensor
X12.11	4-pin IWS Rast plug - Modbus inverter

INSTALLATION
Specification

INSTALLATION Specification

HPG-I 12 (C)S Premium | HPG-I 15 (C)S Premium

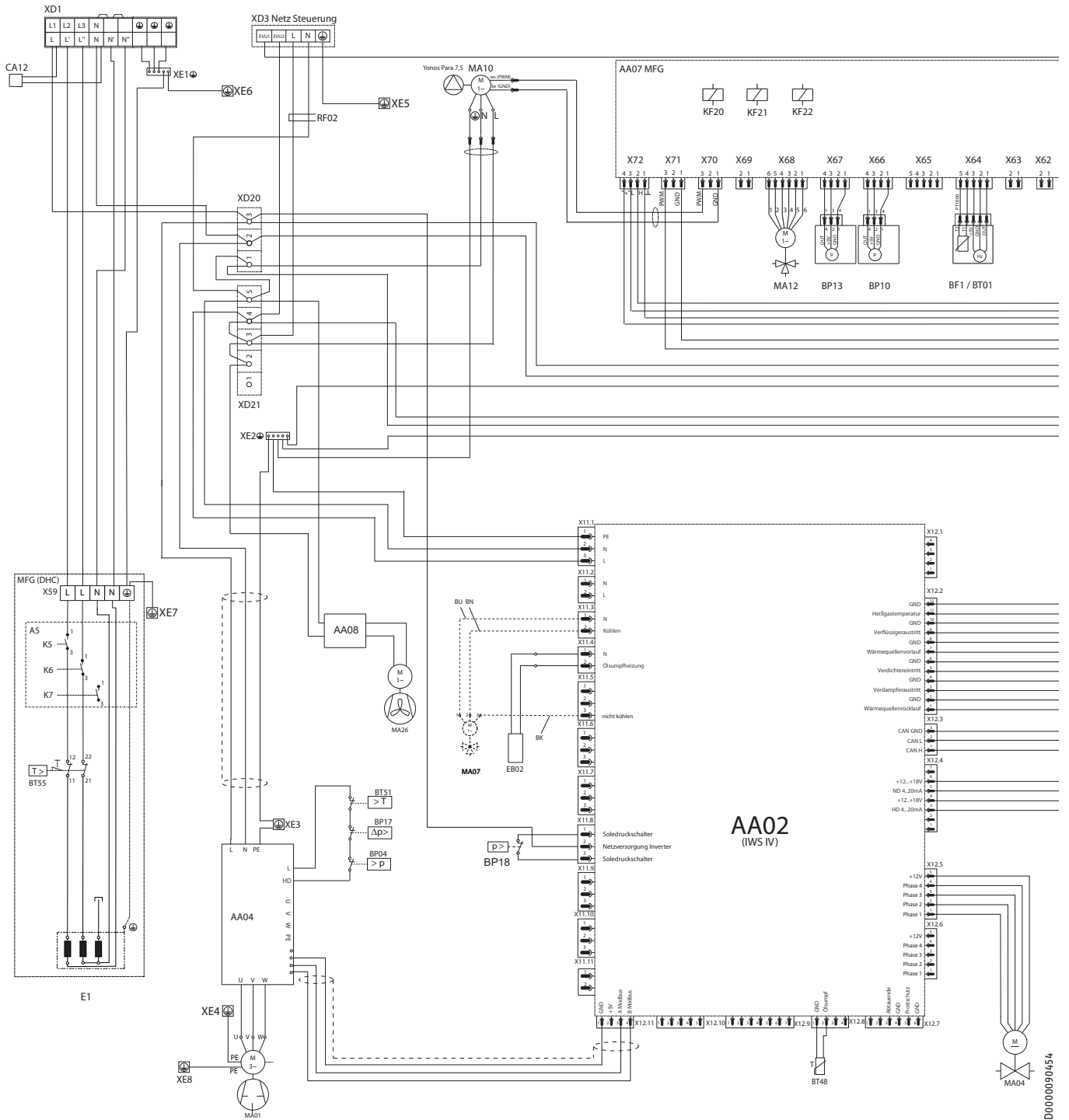

D0000090454

INSTALLATION Specification

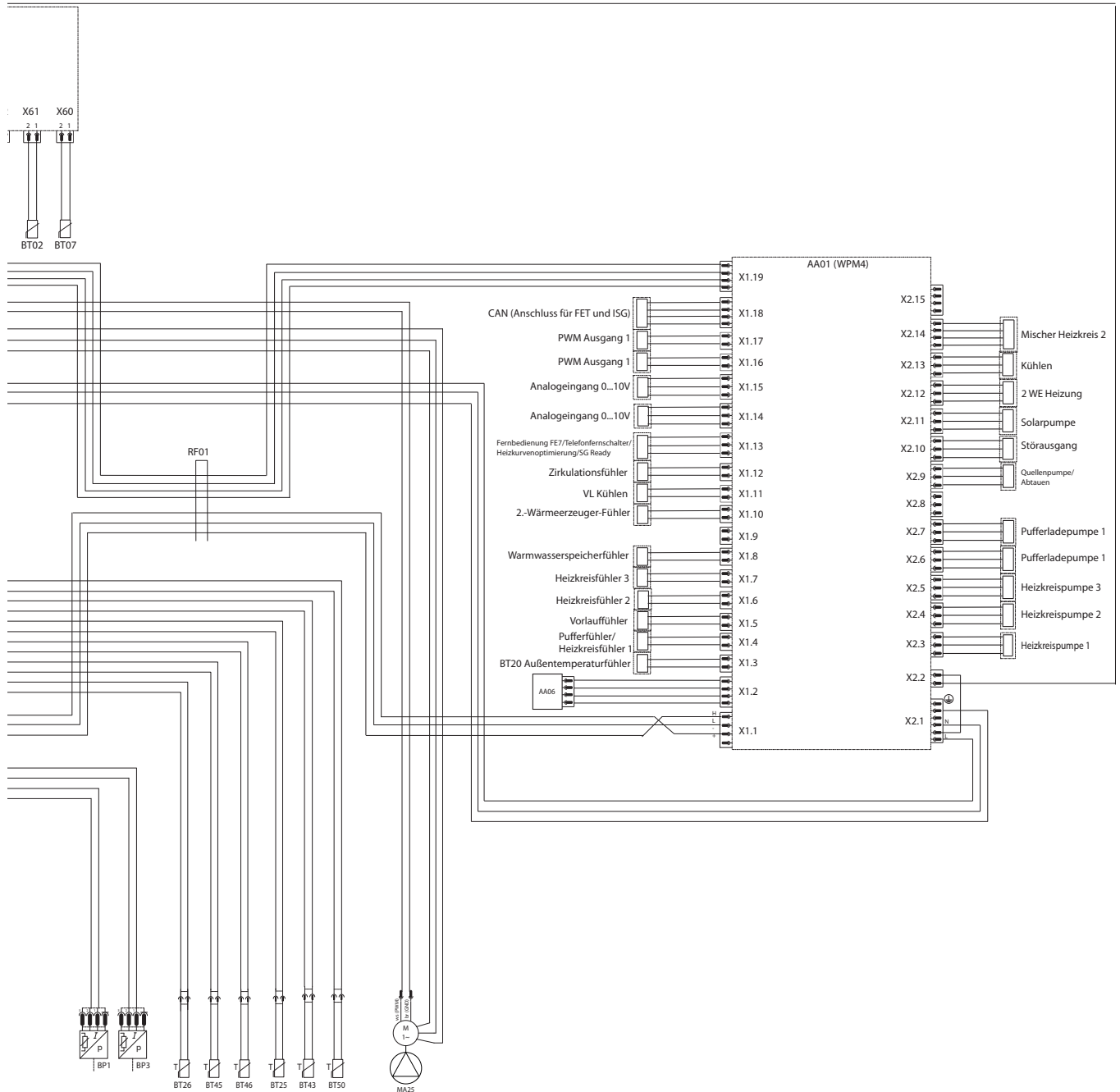

D0000090454

INSTALLATION

Specification

Key			
AA01	Heat pump manager (WPM)	XE2	Earth block
AA02	Integral heat pump control unit (IWS)	XE3	Earth stud, inverter panel
AA04	Inverter compressor	XE4	Earth stud, inverter cooling
AA06	Programming unit	XE5	Earth stud, WPM panel
AA07	Multifunction assembly MFG 3.2	XE6	Earth stud, programming unit panel
AA08	Fan power supply unit	XE7	Earth stud, front panel
BF1	Flow sensor, heating	XE8	Earth stud, oscillation plate
BL01	Float switch	X1.1	WPM CAN IWS
BP1	High pressure sensor (34 bar)	X1.2	WPM CAN programming unit
BP3	Low pressure sensor (16 bar)	X1.3	WPM outside temperature sensor
BP4	High pressure switch (34 bar)	X1.4	WPM buffer cylinder / HC 1
BP10	Heating circuit pressure sensor	X1.6	WPM HC 2
BP13	Heat source pressure sensor	X1.8	WPM DHW sensor
BP17	Internal negative pressure barometric cell	X1.10	WPM 2nd heat generator sensor
BP18	Heat source pressure switch	X1.11	WPM flow, cooling
BT01	Heating flow temperature sensor - Pt1000	X1.12	WPM DHW, bottom
BT02	Heating return temperature sensor - Pt1000	X1.14	WPM analogue input 0-10 V
BT04	Temperature sensor, DHW cylinder	X1.15	WPM analogue input 0-10 V
BT07	Heating flow temperature sensor, multifunction assembly MFG - Pt1000	X1.16	WPM solar circuit pump PWM
		X1.17	WPM 2nd heat generator PWM
		X1.19	WPM CAN MFG
BT20	Outdoor air temperature sensor - Pt1000	X2.1	WPM power supply
BT25	Heat source flow temperature sensor - Pt1000	X2.2	WPM power-OFF
BT26	Heat source return temperature sensor - Pt1000	X2.3	WPM HC pump 1
BT43	Condenser outlet temperature sensor - Pt1000	X2.4	WPM mixer pump 1 / HC pump 2
BT45	Temperature sensor, evaporator discharge	X2.10	WPM fault output
BT46	Compressor intake temperature sensor - Pt1000	X2.11	WPM solar circuit pump
BT48	Oil sump temperature sensor - Pt1000	X2.14	WPM mixer 1
BT50	Hot gas temperature sensor - Pt1000	X11.1	3-pin IWS plug - power supply control
BT51	Temperature switch, compressor housing	X11.3	2-pin IWS plug - defrost valve
BT55	High limit safety cut-out MFG	X11.4	2-pin IWS plug - oil sump heater
CA12	Capacitor, HP power supply	X11.8	3-pin IWS plug - power-OFF
EB02	Oil sump heater	X12.1	4-pin IWS Rast plug - fan PWM
K5	Relay, instantaneous water heater	X12.2	12-pin IWS Rast plug - temperature sensor 1
K6	Relay, instantaneous water heater	X12.3	3-pin IWS Rast plug - BUS connection
K7	Relay, instantaneous water heater	X12.4	7-pin IWS Rast plug - high/low pressure
KF06	Contacteur	X12.5	5-pin IWS Rast plug - expansion valve
KF20	Emergency/booster heater relay, multifunction assembly MFG	X12.6	5-pin IWS Rast plug - inverter cooling valve
KF21	Emergency/booster heater relay, multifunction assembly MFG	X12.7	6-pin IWS Rast plug - temperature sensor 2
KF22	Emergency/booster heater relay, multifunction assembly MFG	X12.9	7-pin IWS Rast plug - air differential pressure sensor
		X12.11	4-pin IWS Rast plug - Modbus inverter
MA01	Compressor motor		
MA04	Electrical expansion valve stepper motor		
MA07	Heating/cooling diverter valve motor		
MA10	Circulation pump		
MA12	DHW heating diverter valve motor		
MA25	Heat source pump motor		
MA26	Suction fan		
RF01	Snap-on ferrite bead, bus cable		
XD1	Terminal, external emergency/booster heater, HP power supply		
XD3	External control terminal		
XD20	Distribution terminal		
XD21	Distribution terminal		
XE1	Earth block		

INSTALLATION
Specification

INSTALLATION Specification

16.3 Output diagrams

16.3.1 HPG-I 04 S Premium | HPG-I 04 CS Premium

Heating output

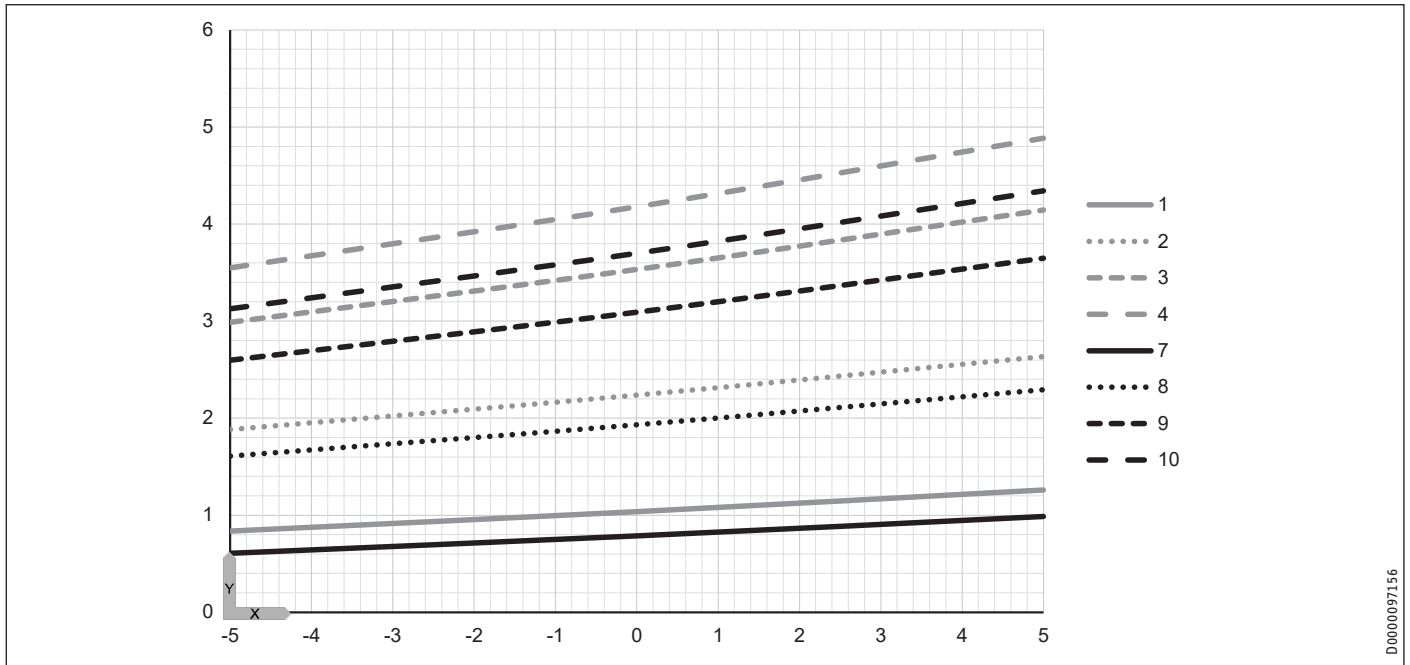

D0000097156

	X: Inlet temperature of the WQA medium [°C]				Y: Heating output [kW]			
Flow temperature	35 °C				55 °C			
Output [Hz]	1: Min.	2: 40	3: 60	4: 80	7: Min.	8: 40	9: 60	10: 80

Power consumption

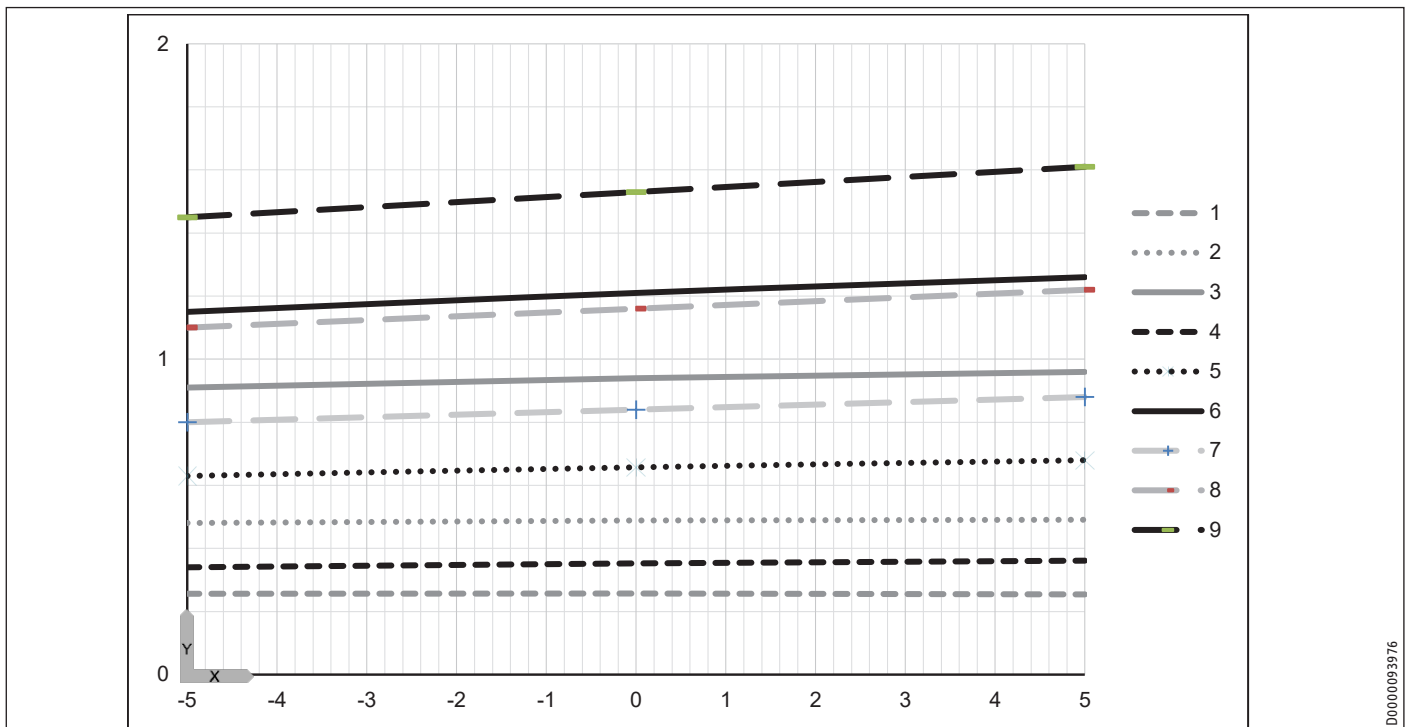

D0000093976

	X: Inlet temperature of the WQA medium [°C]				Y: Power consumption [kW]				
Flow temperature	35 °C				75 °C				
Output [%]	1: 1	2: 50	3: 100	4: 1	5: 50	6: 100	7: 1	8: 50	9: 100

INSTALLATION Specification

Coefficient of performance

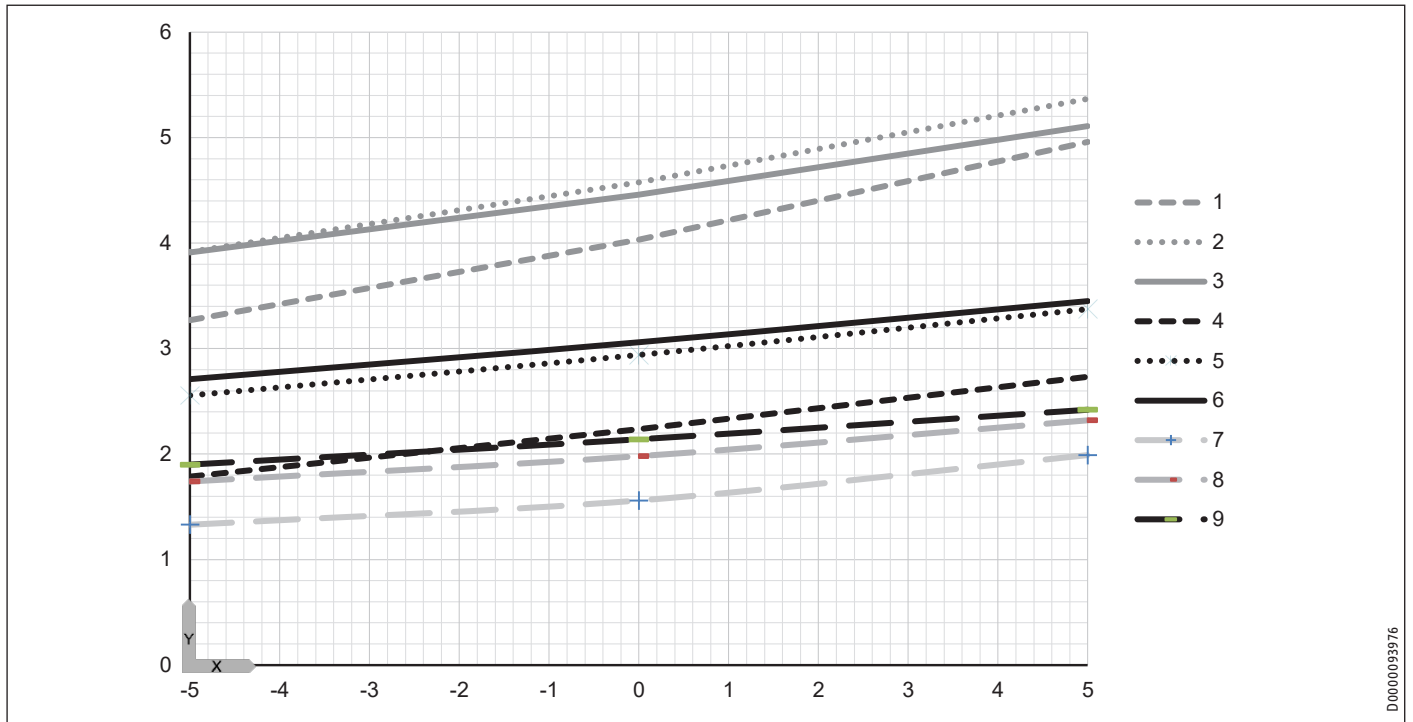

D0000093976

	X: Inlet temperature of the WQA medium [°C]				Y: Coefficient of performance e [-]				
Flow temperature	35 °C		55 °C		75 °C				
Output [%]	1: 1	2: 50	3: 100	4: 1	5: 50	6: 100	7: 1	8: 50	9: 100

Cooling capacity

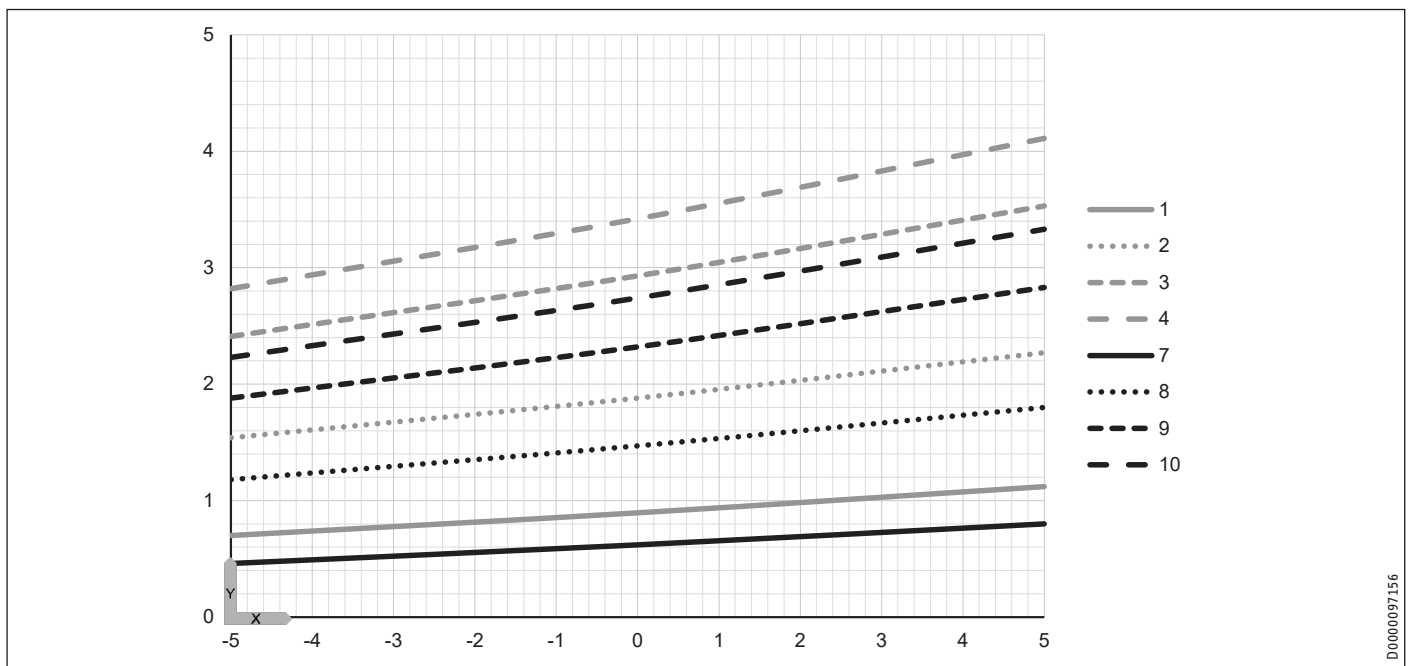

D0000097156

	X: Inlet temperature of the WQA medium [°C]				Y: Cooling capacity [kW]			
Flow temperature	35 °C		55 °C		75 °C			
Output [Hz]	1: Min.	2: 40	3: 60	4: 80	7: Min.	8: 40	9: 60	10: 80

INSTALLATION Specification

16.3.2 HPG-I 06 S Premium | HPG-I 06 CS Premium

Heating output

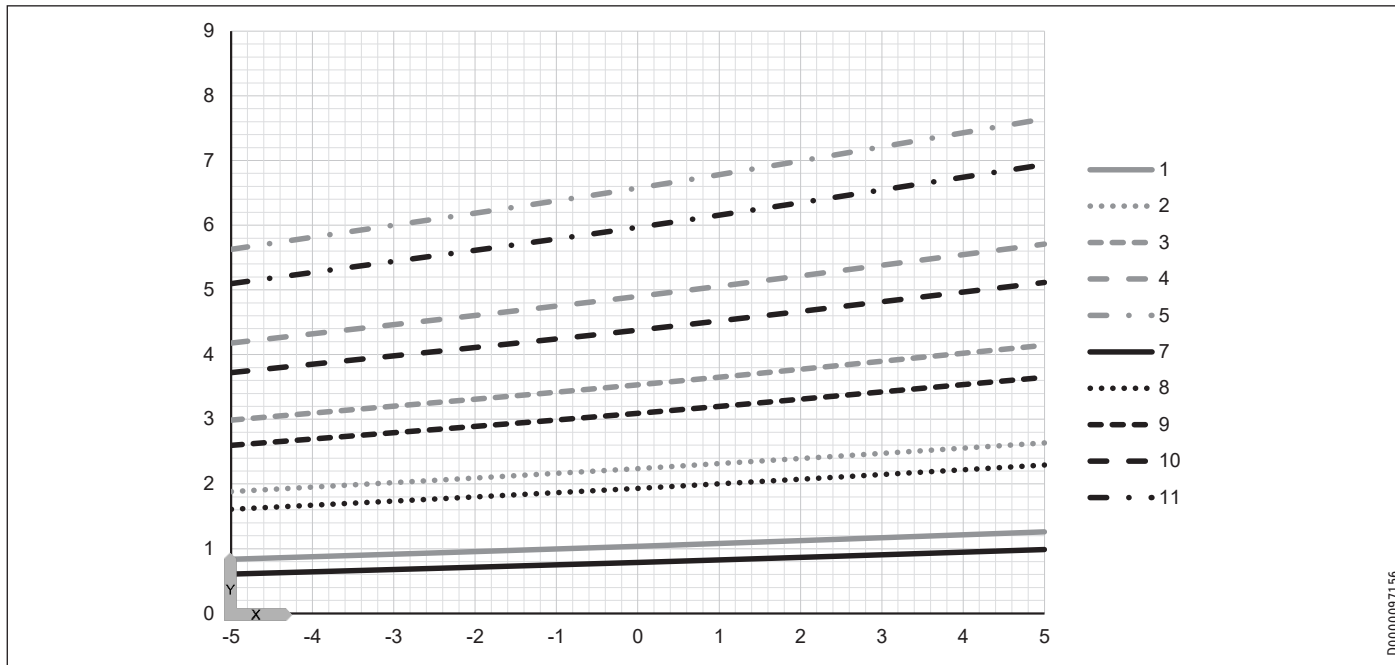

D0000097156

	X: Inlet temperature of the WQA medium [°C]					Y: Heating output [kW]				
Flow temperature	35 °C					55 °C				
Output [Hz]	1: Min.	2: 40	3: 60	4: 80	5: 100	7: Min.	8: 40	9: 60	10: 80	11: 100

Power consumption

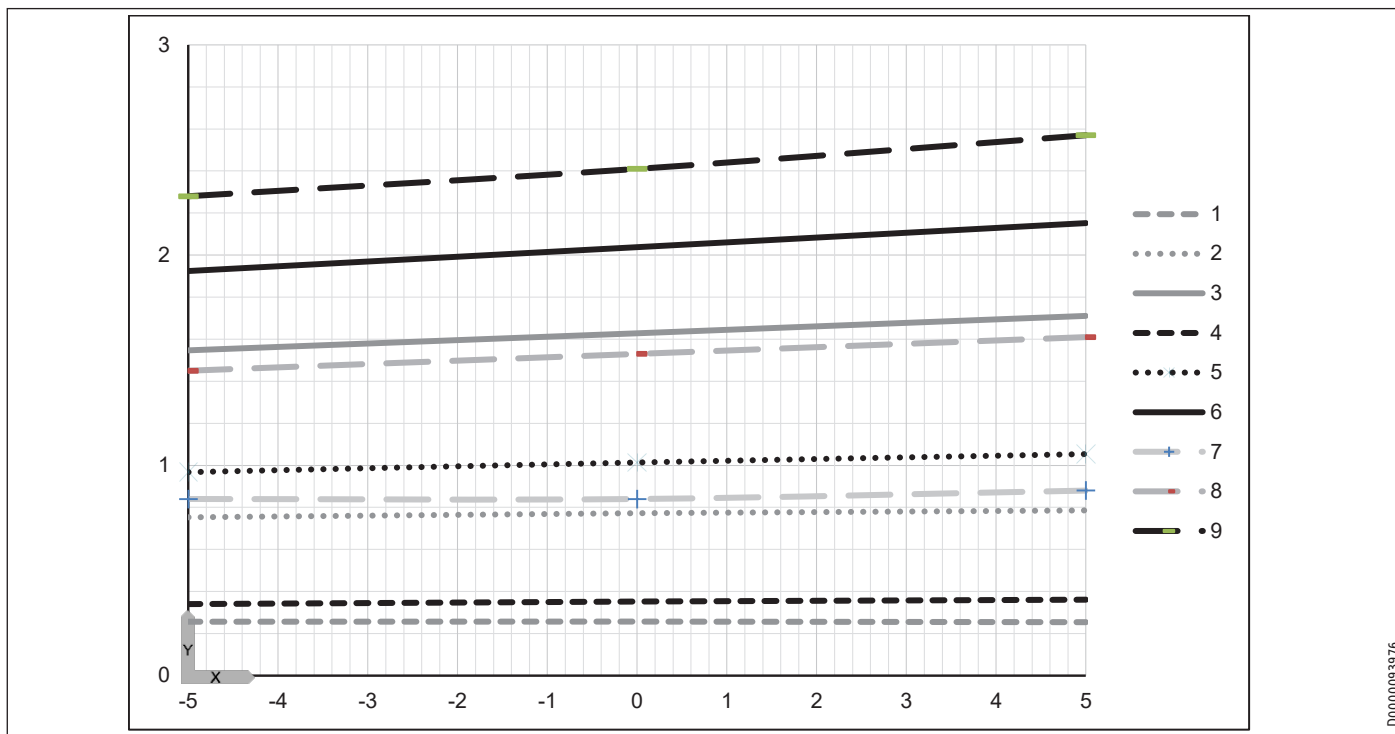

D0000093976

	X: Inlet temperature of the WQA medium [°C]				Y: Power consumption [kW]				
Flow temperature	35 °C				75 °C				
Output [%]	1: 1	2: 50	3: 100	4: 1	5: 50	6: 100	7: 1	8: 50	9: 100

INSTALLATION Specification

Coefficient of performance

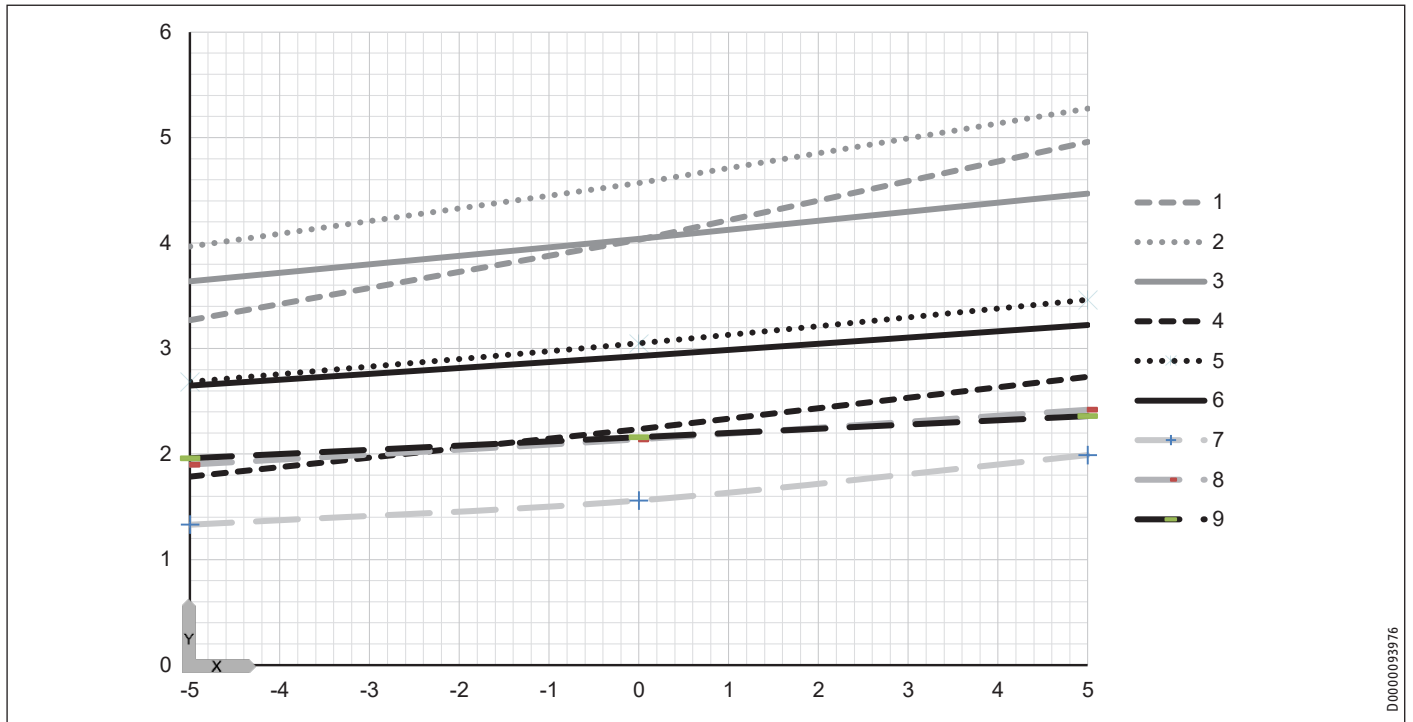

D0000093976

	X: Inlet temperature of the WQA medium [°C]					Y: Coefficient of performance e [-]			
Flow temperature	35 °C		55 °C			75 °C			
Output [%]	1: 1	2: 50	3: 100	4: 1	5: 50	6: 100	7: 1	8: 50	9: 100

Cooling capacity

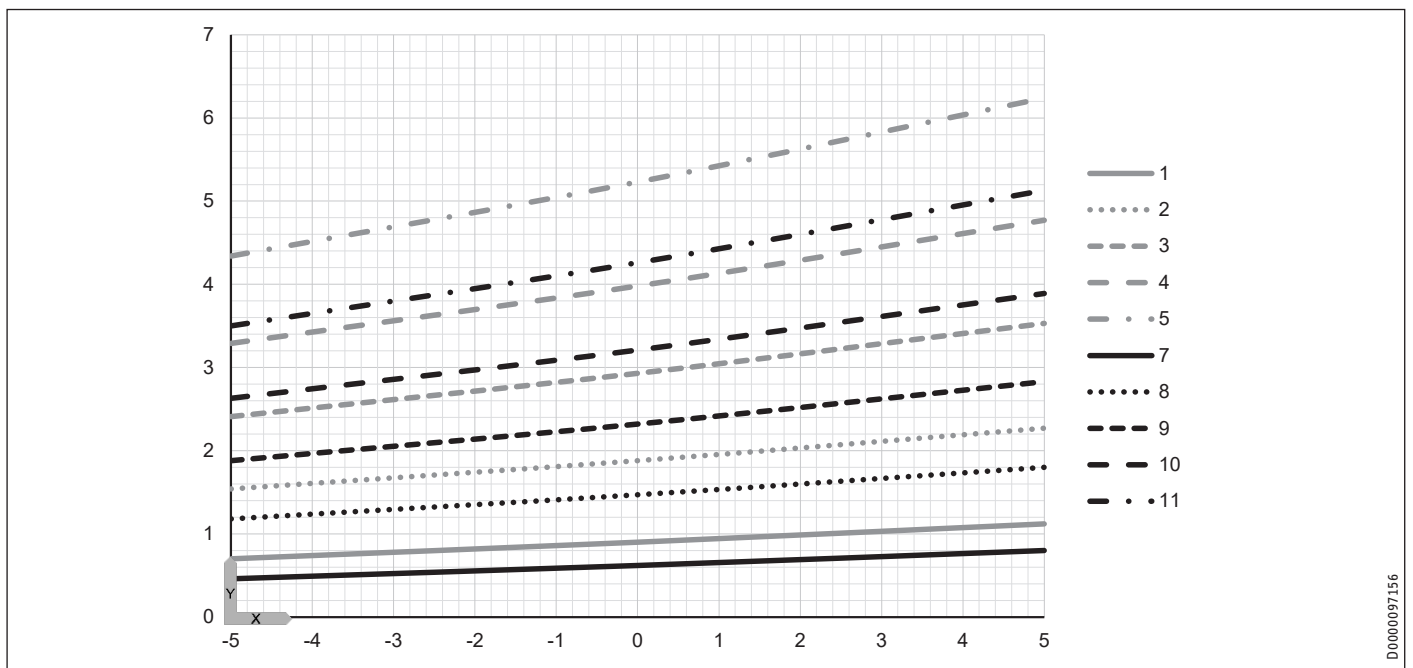

D0000097156

	X: Inlet temperature of the WQA medium [°C]					Y: Cooling capacity [kW]					
Flow temperature	35 °C		55 °C			75 °C					
Output [Hz]	1: Min.	2: 40	3: 60	4: 80	5: 100	7: Min.	8: 40	9: 60	10: 80	11: 100	

INSTALLATION Specification

16.3.3 HPG-I 08 S Premium | HPG-I 08 CS Premium

Heating output

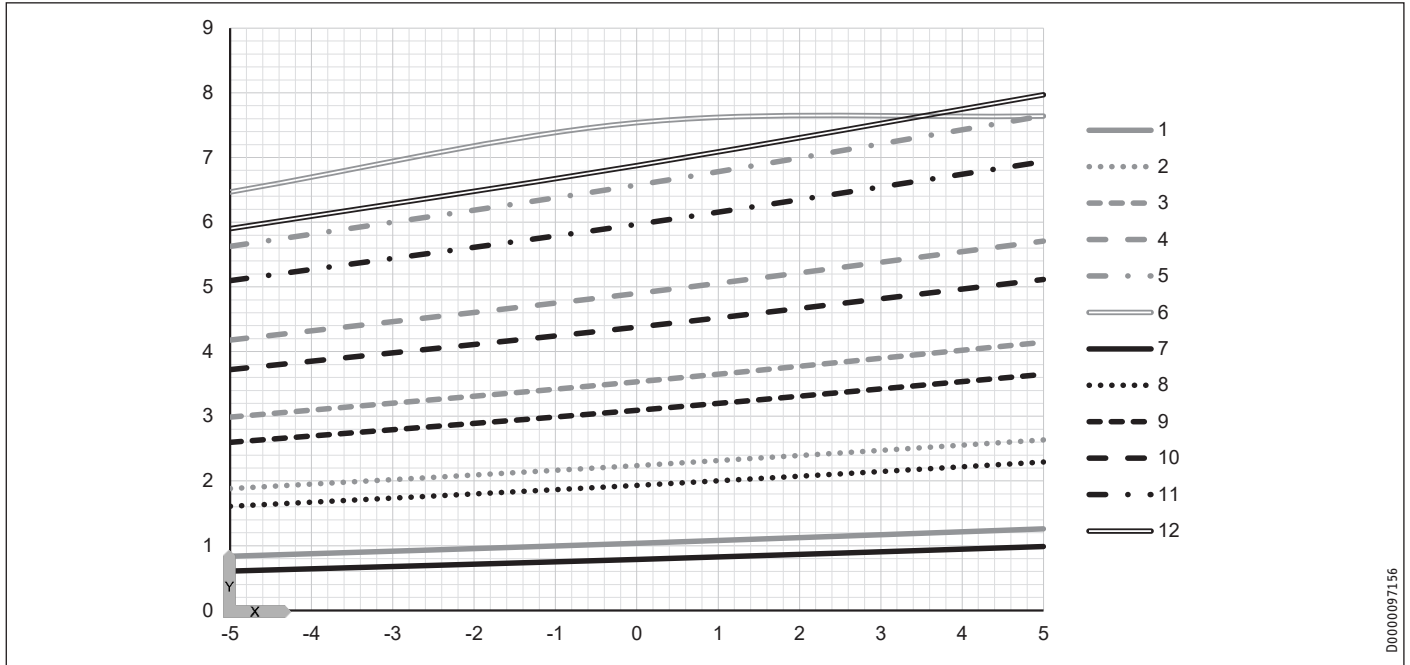

D0000097156

	X: Inlet temperature of the WQA medium [°C]						Y: Heating output [kW]					
Flow temperature	35 °C						55 °C					
Output [Hz]	1: Min.	2: 40	3: 60	4: 80	5: 100	6: Max.	7: Min.	8: 40	9: 60	10: 80	11: 100	12: Max.

Power consumption

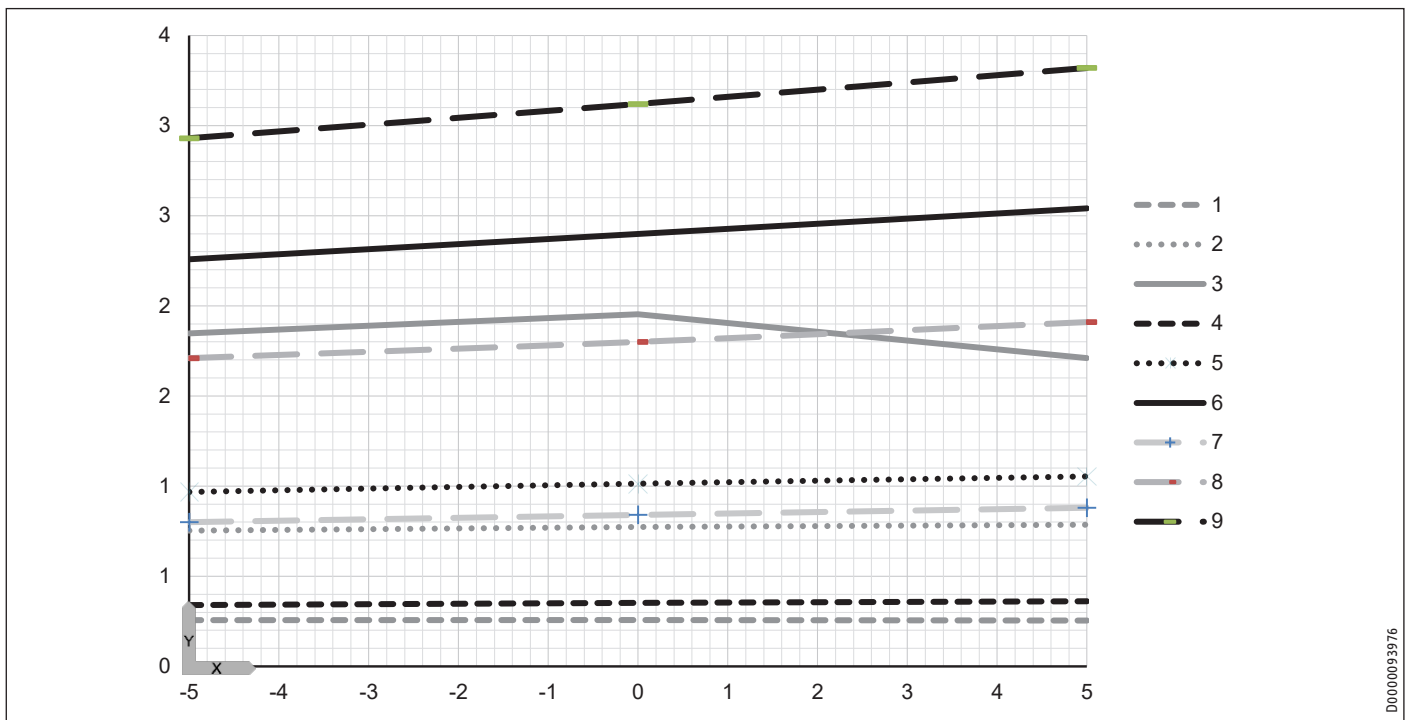

D0000093976

	X: Inlet temperature of the WQA medium [°C]				Y: Power consumption [kW]				
Flow temperature	35 °C				55 °C				
Output [%]	1: 1	2: 50	3: 100	4: 1	5: 50	6: 100	7: 1	8: 50	9: 100

INSTALLATION Specification

Coefficient of performance

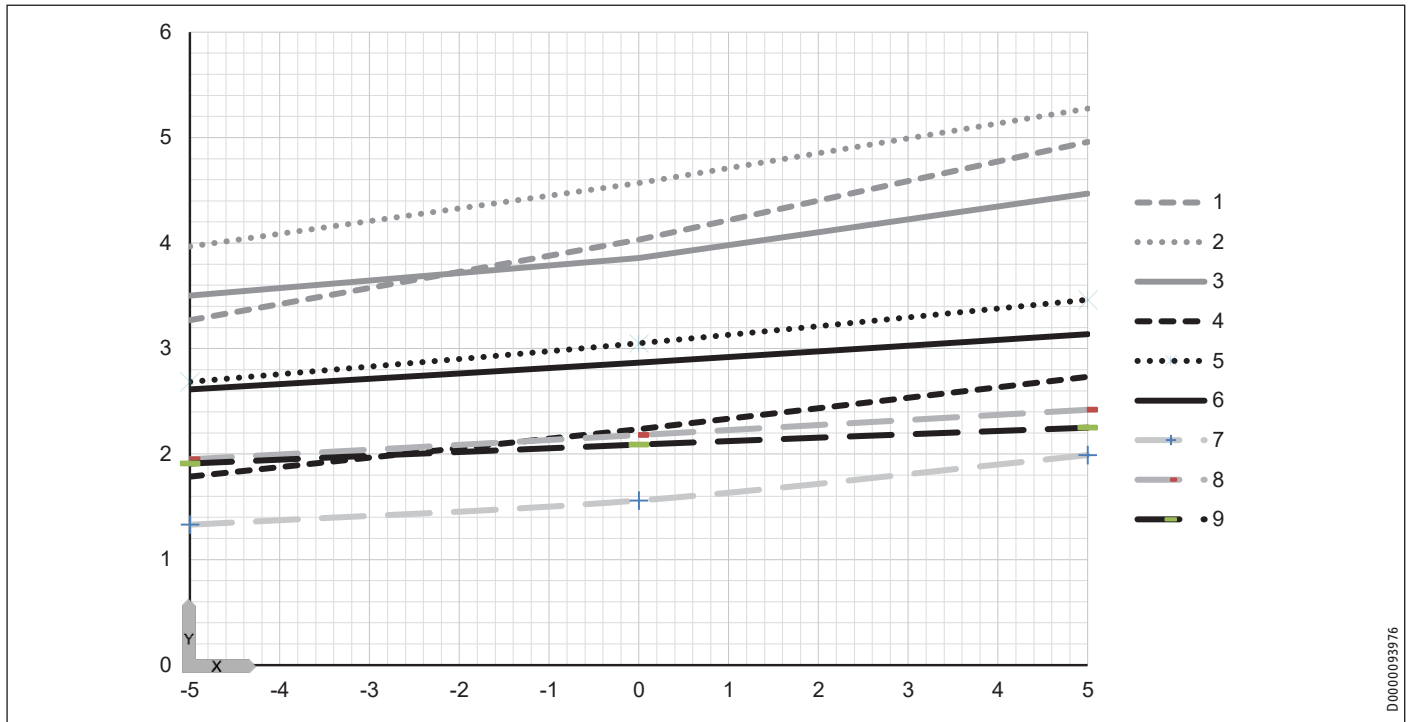

X: Inlet temperature of the WQA medium [°C]

Y: Coefficient of performance e [-]

Flow temperature	35 °C				55 °C				75 °C	
Output [%]	1: 1	2: 50	3: 100	4: 1	5: 50	6: 100	7: 1	8: 50	9: 100	

Cooling capacity

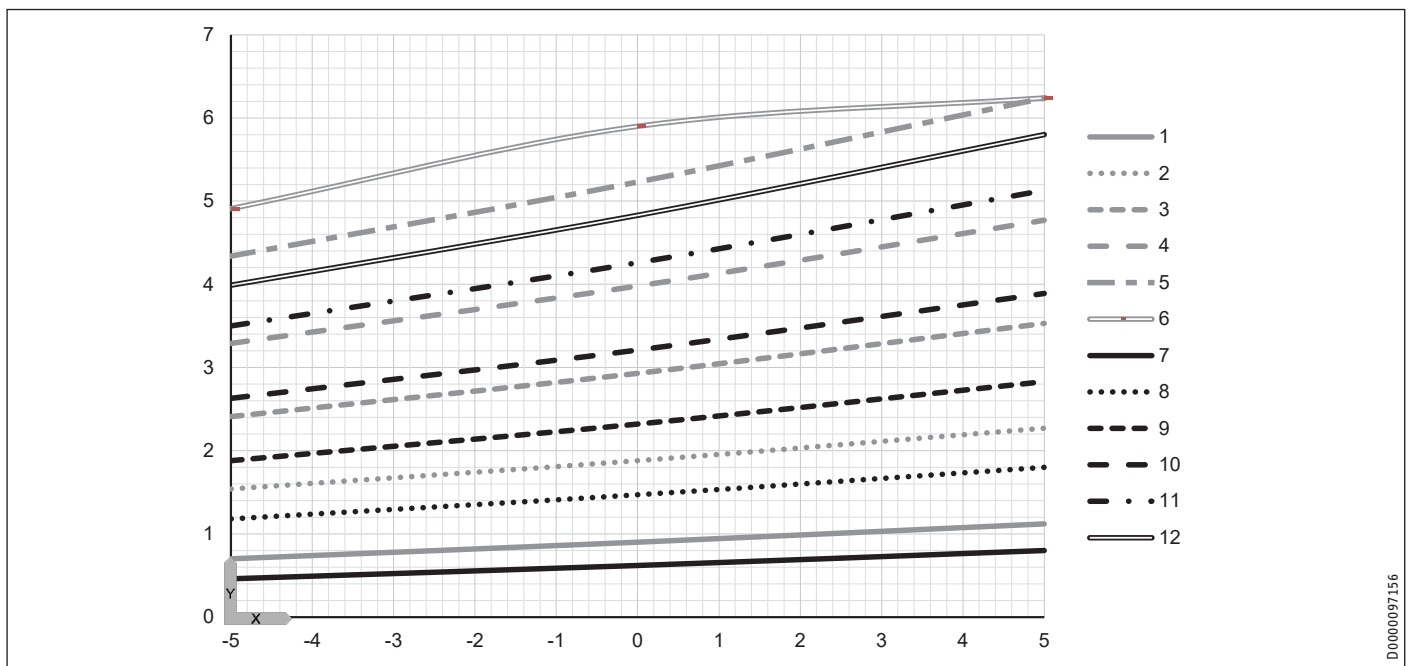

X: Inlet temperature of the WQA medium [°C]

Y: Cooling capacity [kW]

Flow temperature	35 °C					55 °C						
Output [Hz]	1: Min.	2: 40	3: 60	4: 80	5: 100	6: Max.	7: Min.	8: 40	9: 60	10: 80	11: 100	12: Max.

INSTALLATION Specification

16.3.4 HPG-I 12 S Premium | HPG-I 12 CS Premium

Heating output

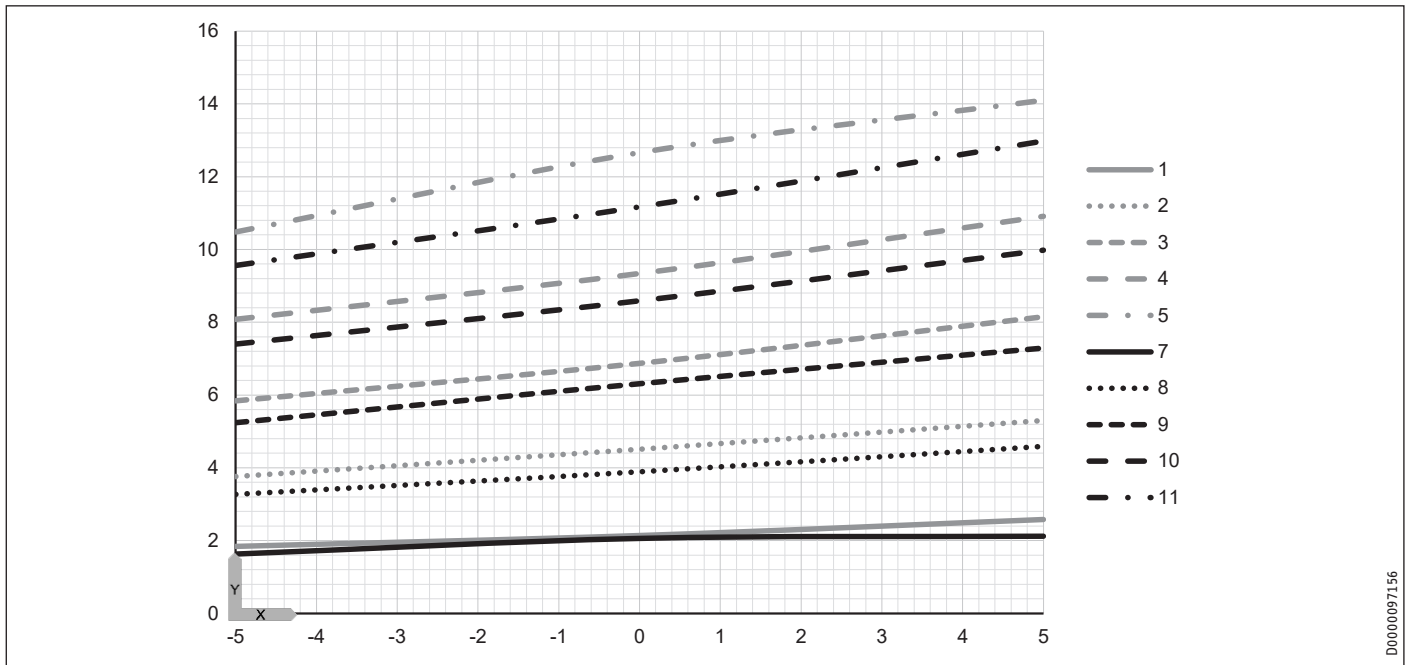

D0000097156

Flow temperature	X: Inlet temperature of the WQA medium [°C]					Y: Heating output [kW]				
Output [Hz]	35 °C	40	60	80	100	55 °C	60	80	100	110
	1: Min.	2: 40	3: 60	4: 80	5: 100	7: Min.	8: 40	9: 60	10: 80	11: 100

Power consumption

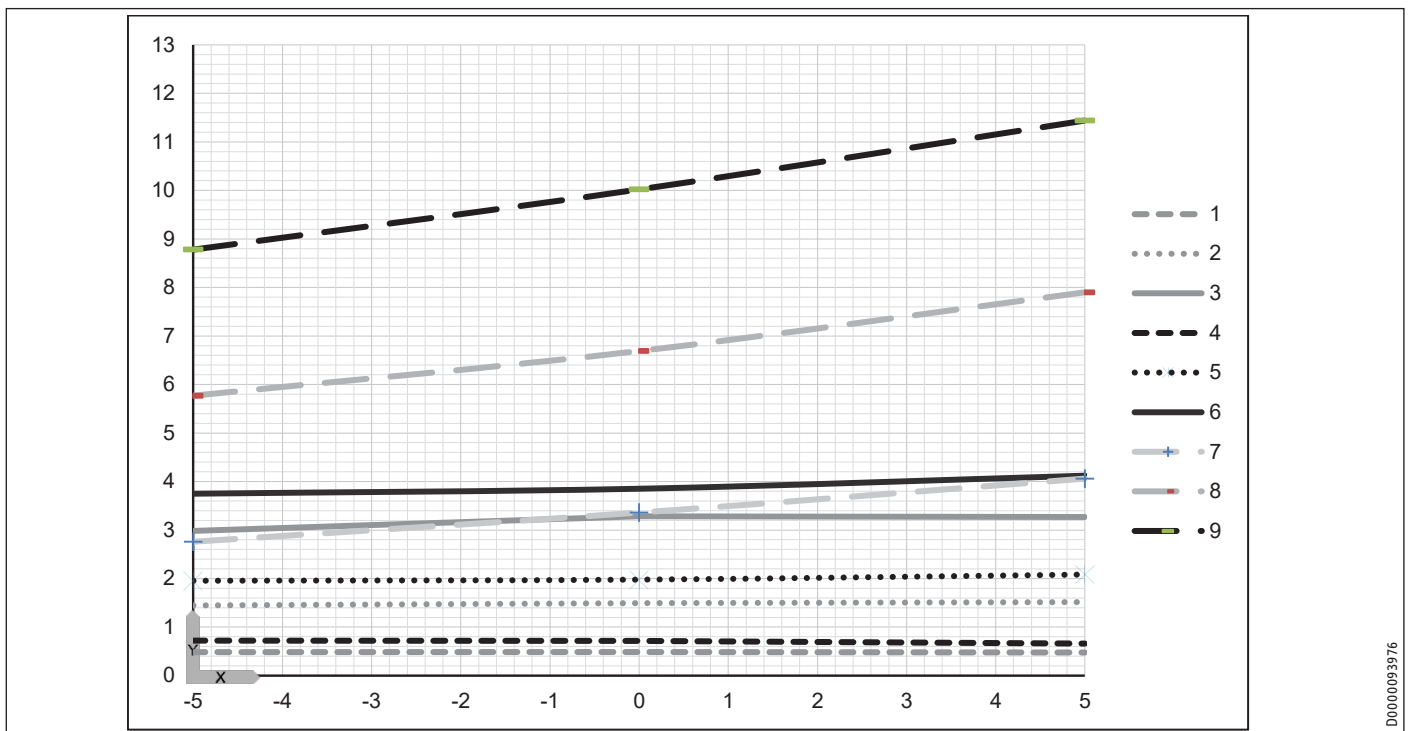

D0000093976

Flow temperature	X: Inlet temperature of the WQA medium [°C]				Y: Power consumption [kW]				
Output [%]	35 °C	50	100	55 °C	75 °C	1	50	100	100
	1: 1	2: 50	3: 100	4: 1	5: 50	6: 100	7: 1	8: 50	9: 100

INSTALLATION Specification

Coefficient of performance

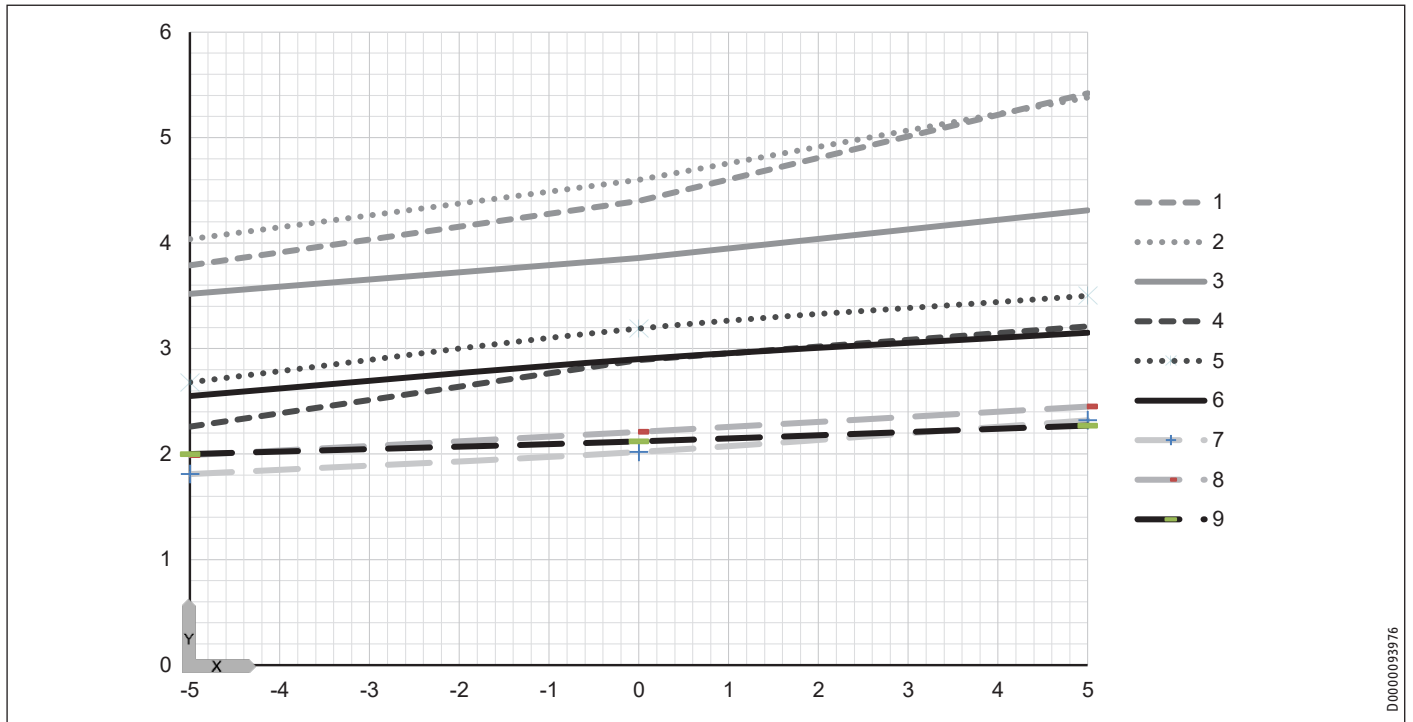

	X: Inlet temperature of the WQA medium [°C]				Y: Coefficient of performance e [-]				
Flow temperature	35 °C		55 °C		75 °C				
Output [%]	1: 1	2: 50	3: 100	4: 1	5: 50	6: 100	7: 1	8: 50	9: 100

Cooling capacity

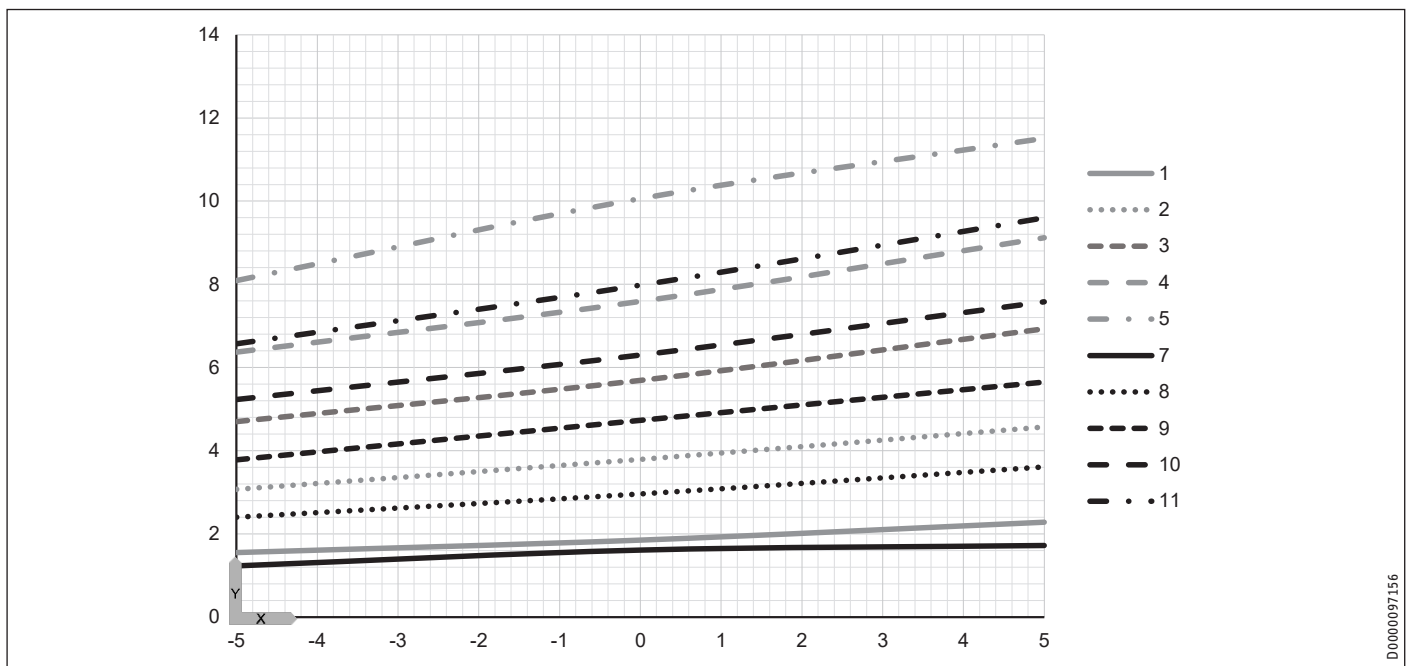

	X: Inlet temperature of the WQA medium [°C]					Y: Cooling capacity [kW]				
Flow temperature	35 °C					55 °C				
Output [Hz]	1: Min.	2: 40	3: 60	4: 80	5: 100	7: Min.	8: 40	9: 60	10: 80	11: 100

INSTALLATION Specification

16.3.5 HPG-I 15 S Premium | HPG-I 15 CS Premium

Heating output

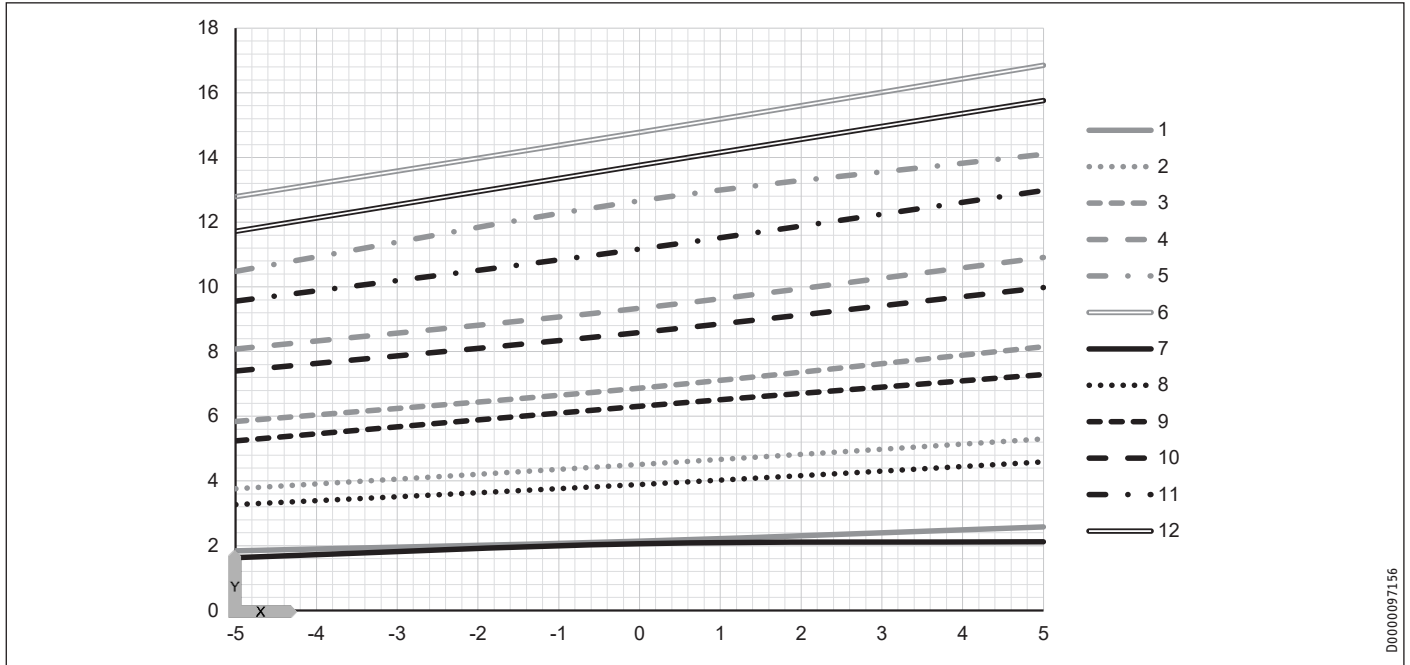

D0000097156

	X: Inlet temperature of the WQA medium [°C]						Y: Heating output [kW]					
Flow temperature	35 °C						55 °C					
Output [Hz]	1: Min.	2: 40	3: 60	4: 80	5: 100	6: Max.	7: Min.	8: 40	9: 60	10: 80	11: 100	12: Max.

Power consumption

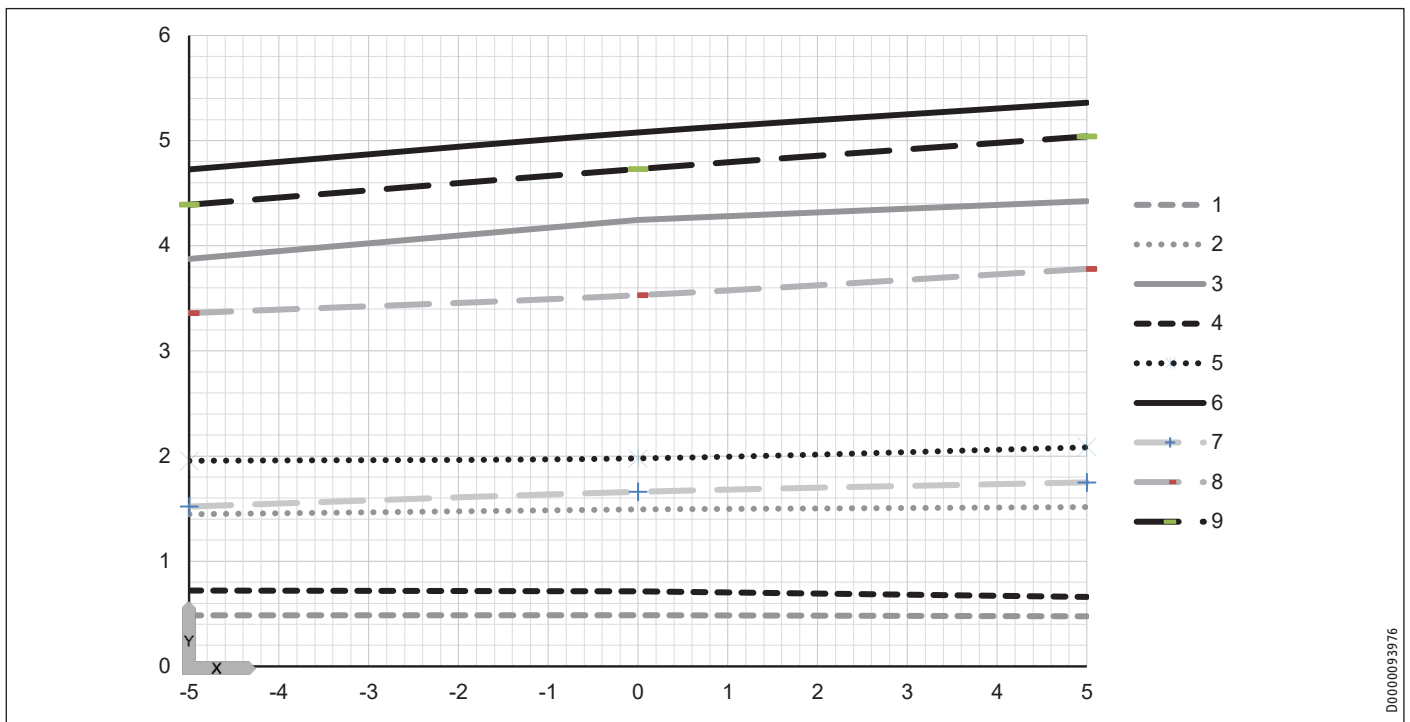

D0000093976

	X: Inlet temperature of the WQA medium [°C]				Y: Power consumption [kW]				
Flow temperature	35 °C				75 °C				
Output [%]	1: 1	2: 50	3: 100	4: 1	5: 50	6: 100	7: 1	8: 50	9: 100

INSTALLATION Specification

Coefficient of performance

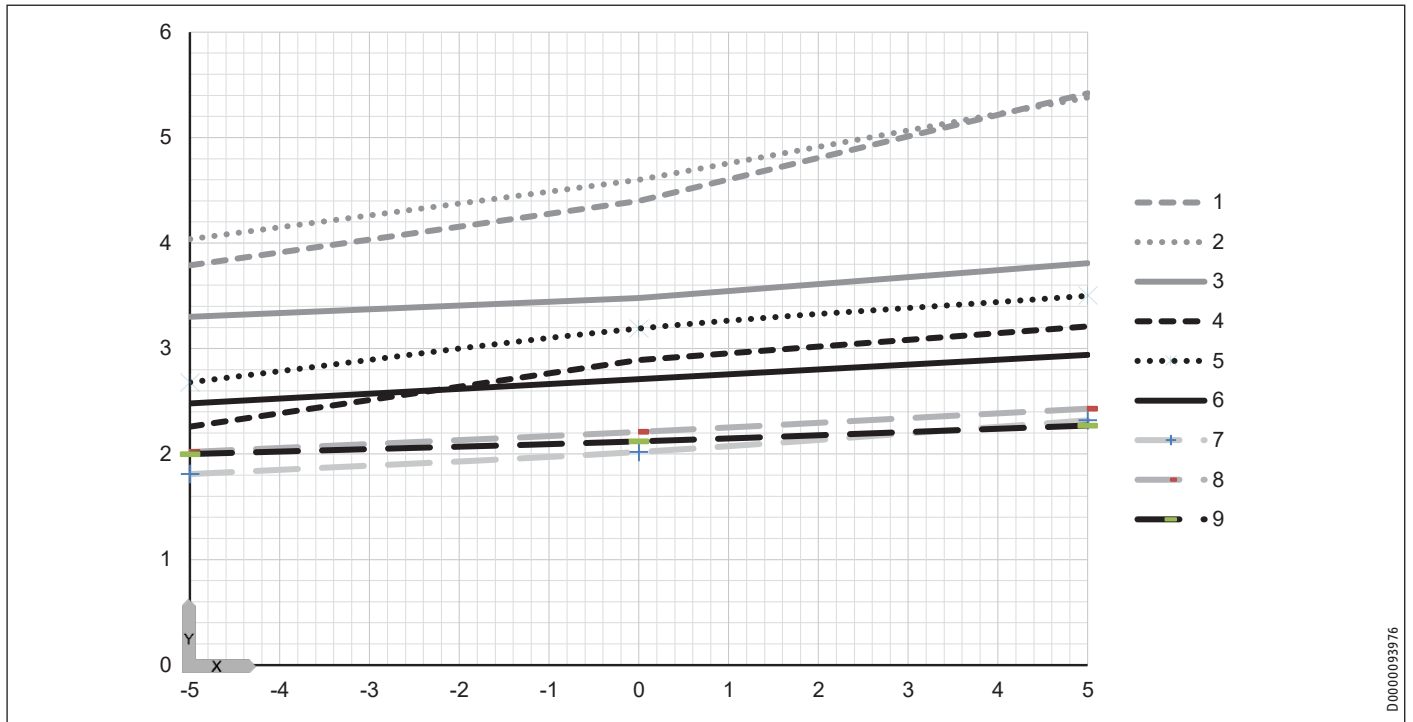

X: Inlet temperature of the WQA medium [°C]

Y: Coefficient of performance e [-]

Flow temperature	35 °C				55 °C			75 °C	
Output [%]	1: 1	2: 50	3: 100	4: 1	5: 50	6: 100	7: 1	8: 50	9: 100

Cooling capacity

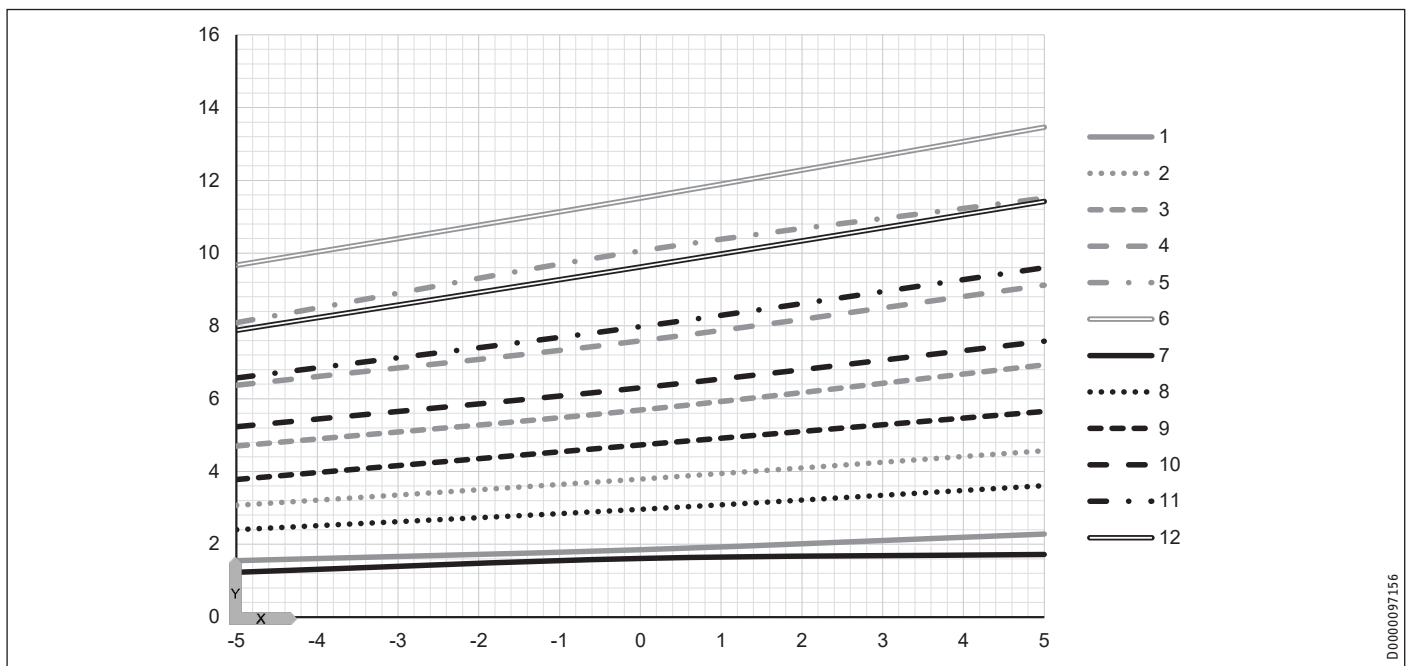

X: Inlet temperature of the WQA medium [°C]

Y: Cooling capacity [kW]

Flow temperature	35 °C						55 °C					
Output [Hz]	1: Min.	2: 40	3: 60	4: 80	5: 100	6: Max.	7: Min.	8: 40	9: 60	10: 80	11: 100	12: Max.

INSTALLATION Specification

16.4 Data table

HPG-I S Premium

Output details apply to new appliances with clean heat exchangers.

The power consumption figures for the integral auxiliary drives are maximum values and may vary subject to operating point.

The power consumption of the integral auxiliary drives is included in the output details of the heat pump (to EN 14511).

		HPG-I 04 S Premium	HPG-I 06 S Premium	HPG-I 08 S Premium	HPG-I 12 S Premium	HPG-I 15 S Premium
		202617	202618	202619	202620	202621
Heating output						
Heating output at B0/W35 (min./max.)	kW	1.0 - 4.2	1.0 - 6.6	1.0 - 7.6	2.1 - 12.7	2.1 - 14.8
Heating output at B0/W35 (EN 14511)	kW	1.96	2.37	2.78	4.19	5.18
Heating output at B0/W55 (EN 14511)	kW	1.28	2.01	2.42	4.20	4.72
Heating output at B10/W35 (min./max.)	kW	1.0 - 5.71	1.0 - 7.36	1.0 - 7.36	2.1 - 15.38	2.1 - 15.33
Heating output at B5/W55(min./max.)	kW	1.0 - 4.34	1.0 - 6.94	1.0 - 7.97	2.1 - 12.98	2.1 - 15.76
Heating output at B10/W55 (min./max.)	kW	1.0 - 5.16	1.0 - 8.12	1.0 - 8.89	2.1 - 15.23	2.1 - 17.17
Heating output at B5/W35 (min./max.)	kW	1.0 - 4.88	1.0 - 7.64	1.0 - 7.82	2.1 - 14.10	2.1 - 16.85
Power consumption						
Power consumption at B0/W35 (EN 14511)	kW	0.43	0.52	0.6	0.84	1.07
Power consumption at B0/W55 (EN 14511)	kW	0.47	0.69	0.79	1.34	1.48
Power consumption, emergency/auxiliary heater	kW	5.90	5.90	5.90	5.90	5.90
Max. power consumption, circulation pump, heating side	W	45.00	45.00	45.00	76.00	76.00
Max. power consumption, circulation pump, source side	W	140.00	140.00	140.00	140.00	140.00
Coefficients of performance						
SCOP (EN 14825)		5.07	5.20	5.12	5.59	5.44
COP at B0/W35 (EN 14511)		4.60	4.60	4.67	5.01	4.86
COP at B0/W55 (EN 14511)		2.73	2.91	3.07	3.13	3.18
Sound emissions						
Sound power level (EN 12102)	dB(A)	38 - 40	38 - 43	38 - 45	39 - 46	39 - 47
Application limits						
Max. permissible pressure	MPa	0.30	0.30	0.30	0.30	0.30
Max. heating flow temperature	°C	75	75	75	75	75
Min. application limit on heating side	°C	15	15	15	15	15
Min./max. application limits for heat source	°C	-5/+20	-5/+20	-5/+20	-5/+20	-5/+20
Shutdown pressure, brine pressure switch (positive pressure)	MPa	0.07	0.07	0.07	0.07	0.07
Energy data						
Energy efficiency class, moderate climate, W55/W35		A+++/A+++	A+++/A+++	A+++/A+++	A+++/A+++	A+++/A+++
Electrical data						
Starting current (with/without starting current limiter)	A	<6	<6	<6	<10	<10
Emergency/auxiliary heater fuse protection	A	2 x B 16	2 x B 16	2 x B 16	2 x B 16	2 x B 16
Control unit fuse protection	A	1 x B 16	1 x B 16	1 x B 16	1 x B 16	1 x B 16
Compressor fuse protection	A	1x B 16	1 x B 16	1 x B 16	1 x B 25	1 x B 25
Rated voltage, emergency/auxiliary heater	V	230	230	230	230	230
Rated voltage, control unit	V	230	230	230	230	230
Rated voltage, compressor	V	230	230	230	230	230
Frequency	Hz	50	50	50	50	50
Phases, emergency/auxiliary heater		2/N/PE	2/N/PE	2/N/PE	2/N/PE	2/N/PE
Phases, control unit		1/N/PE	1/N/PE	1/N/PE	1/N/PE	1/N/PE
Phases, compressor		1/N/PE	1/N/PE	1/N/PE	1/N/PE	1/N/PE
Max. operating current	A	8.4	13	15.09	24.32	24.48
Versions						
Refrigerant		R454 C	R454 C	R454 C	R454 C	R454 C
Refrigerant charge	kg	2.2	2.2	2.2	3.1	3.1
Global warming potential of the refrigerant (GWP100)		148	148	148	148	148
CO ₂ equivalent (CO ₂ e)	t	0.32	0.32	0.32	0.45	0.45
Condenser material		1.4401/Cu	1.4401/Cu	1.4401/Cu	1.4401/Cu	1.4401/Cu
Evaporator material		1.4401/Cu	1.4401/Cu	1.4401/Cu	1.4401/Cu	1.4401/Cu
Circulation pump type, heating side		Yonos PARA 25/7.0	Yonos PARA 25/7.0	Yonos PARA 25/7.0	Yonos PARA 25/7.5	Yonos PARA 25/7.5
Circulation pump type, source side		Grundfos UPML	Grundfos UPML	Grundfos UPML	Grundfos UPML	Grundfos UPML
IP rating		IP20	IP20	IP20	IP20	IP20

INSTALLATION

Specification

		HPG-I 04 S Premium	HPG-I 06 S Premium	HPG-I 08 S Premium	HPG-I 12 S Premium	HPG-I 15 S Premium
Dimensions						
Height	mm	1369	1369	1369	1369	1369
Width	mm	598	598	598	598	598
Depth	mm	658	695	658	658	658
Weights						
Weight	kg	180	180	180	190	190
Connections						
DHW flow/return push-fit connection		28 mm	28 mm	28 mm	28 mm	28 mm
Heat source flow/return push-fit connection		28 mm	28 mm	28 mm	28 mm	28 mm
Heating flow/return push-fit connection		28 mm	28 mm	28 mm	28 mm	28 mm
Heating water quality requirements						
Water hardness	°dH	≤3	≤3	≤3	≤3	≤3
pH value (with aluminium fittings)		8.0-8.5	8.0-8.5	8.0-8.5	8.0-8.5	8.0-8.5
pH value (without aluminium fittings)		8.0-10.0	8.0-10.0	8.0-10.0	8.0-10.0	8.0-10.0
Chloride	mg/l	< 30	< 30	< 30	< 30	< 30
Conductivity (desalination)	µS/cm	20-100	20-100	20-100	20-100	20-100
Conductivity (softening)	µS/cm	< 1000	< 1000	< 1000	< 1000	< 1000
Oxygen 8-12 weeks after filling (softening)	mg/l	<0.02	<0.02	<0.02	<0.02	<0.02
Oxygen 8-12 weeks after filling (desalination)	mg/l	< 0.1	< 0.1	< 0.1	< 0.1	< 0.1
Heat transfer medium requirements on the heat source side						
Ethylene glycol concentration, geothermal probe	Vol.-%	25	25	25	25	25
Ethylene glycol concentration, geothermal collector	Vol.-%	33	33	33	33	33
Values						
Min. flow rate, heating	m ³ /h	0.3	0.3	0.3	0.3	0.3
Heating flow rate (EN 14511) at A7/W35, B0/W35 and 5 K	m ³ /h	0.34	0.41	0.48	0.74	0.9
Heating flow rate max. at B0/W35 and 8 K	m ³ /h	0.45	0.71	0.81	1.36	1.59
Available external pressure differential, heating, max. at B0/W35 and 8 K	hPa	708	642	603	571	462
flow rate on heat source side at B0/W35 and 3 K	m ³ /h	0.5	0.6	0.68	1.08	1.31
Max. flow rate on heat source side at B0/W35 and 3 K	m ³ /h	1.05	1.61	1.82	3.1	3.55
Max. available external pressure differential on heat source side at B0/W35 and 3 K	hPa	927	702	590	319	74
Internal volume, heating side	l	28.4	28.4	28.4	29.1	29.1
Internal volume, source side	l	26.5	26.5	26.5	27.9	27.9
Expansion vessel pre-charge pressure on the heating side	MPa	0.15	0.15	0.15	0.15	0.15
Expansion vessel volume on the heating side	l	24	24	24	24	24
Expansion vessel pre-charge pressure on the source side	MPa	0.05	0.05	0.05	0.05	0.05
Expansion vessel volume on the source side	l	24	24	24	24	24

Conversion: 1 m³/h = 16.67 l/min

Further details

		HPG-I 04 S Premium	HPG-I 06 S Premium	HPG-I 08 S Premium	HPG-I 12 S Premium	HPG-I 15 S Premium
		202617	202618	202619	202620	202621
Maximum altitude for installation	m	2000	2000	2000	2000	2000

INSTALLATION Specification

HPG-I CS Premium

Output details apply to new appliances with clean heat exchangers.

The power consumption figures for the integral auxiliary drives are maximum values and may vary subject to operating point.

The power consumption of the integral auxiliary drives is included in the output details of the heat pump (to EN 14511).

		HPG-I 04 CS Premium	HPG-I 06 CS Premium	HPG-I 08 CS Premium	HPG-I 12 CS Premium	HPG-I 15 CS Premium
		202627	202628	202629	202630	202631
Heating output						
Heating output at B0/W35 (min./max.)	kW	1.0 - 4.2	1.0 - 6.6	1.0 - 7.6	2.1 - 12.7	2.1 - 14.8
Heating output at B0/W35 (EN 14511)	kW	1.96	2.37	2.78	4.19	5.18
Heating output at B0/W55 (EN 14511)	kW	1.28	2.01	2.42	4.20	4.72
Heating output at B10/W35 (min./max.)	kW	1.0 - 5.71	1.0 - 7.36	1.0 - 7.36	2.1 - 15.38	2.1 - 15.33
Cooling capacity at B15/W23	kW	2.5	3	4	6	8
Heating output at B5/W55(min./max.)	kW	1.0 - 4.34	1.0 - 6.94	1.0 - 7.97	2.1 - 12.98	2.1 - 15.76
Heating output at B10/W55 (min./max.)	kW	1.0 - 5.16	1.0 - 8.12	1.0 - 8.89	2.1 - 15.23	2.1 - 17.17
Heating output at B5/W35 (min./max.)	kW	1.0 - 4.88	1.0 - 7.64	1.0 - 7.82	2.1 - 14.10	2.1 - 16.85
Power consumption						
Power consumption at B0/W35 (EN 14511)	kW	0.43	0.52	0.6	0.84	1.07
Power consumption at B0/W55 (EN 14511)	kW	0.47	0.69	0.79	1.34	1.48
Power consumption, emergency/auxiliary heater	kW	5.90	5.90	5.90	5.90	5.90
Max. power consumption, circulation pump, heating side	W	45.00	45.00	45.00	76.00	76.00
Max. power consumption, circulation pump, source side	W	140.00	140.00	140.00	140.00	140.00
Coefficients of performance						
SCOP (EN 14825)		5.07	5.20	5.12	5.59	5.44
COP at B0/W35 (EN 14511)		4.60	4.60	4.67	5.01	4.86
COP at B0/W55 (EN 14511)		2.73	2.91	3.07	3.13	3.18
Sound emissions						
Sound power level (EN 12102)	dB(A)	38 - 40	38 - 43	38 - 45	39 - 46	39 - 47
Application limits						
Max. permissible pressure	MPa	0.30	0.30	0.30	0.30	0.30
Max. heating flow temperature	°C	75	75	75	75	75
Min. application limit on heating side	°C	15	15	15	15	15
Min./max. application limits for heat source	°C	-5/+20	-5/+20	-5/+20	-5/+20	-5/+20
Shutdown pressure, brine pressure switch (positive pressure)	MPa	0.07	0.07	0.07	0.07	0.07
Energy data						
Energy efficiency class, moderate climate, W55/W35		A+++/A+++	A+++/A+++	A+++/A+++	A+++/A+++	A+++/A+++
Electrical data						
Starting current (with/without starting current limiter)	A	<6	<6	<6	<10	<10
Emergency/auxiliary heater fuse protection	A	2 x B 16	2 x B 16	2 x B 16	2 x B 16	2 x B 16
Control unit fuse protection	A	1 x B 16	1 x B 16	1 x B 16	1 x B 16	1 x B 16
Compressor fuse protection	A	1x B 16	1 x B 16	1 x B 16	1 x B 25	1 x B 25
Rated voltage, emergency/auxiliary heater	V	230	230	230	230	230
Rated voltage, control unit	V	230	230	230	230	230
Rated voltage, compressor	V	230	230	230	230	230
Frequency	Hz	50	50	50	50	50
Phases, emergency/auxiliary heater		2/N/PE	2/N/PE	2/N/PE	2/N/PE	2/N/PE
Phases, control unit		1/N/PE	1/N/PE	1/N/PE	1/N/PE	1/N/PE
Phases, compressor		1/N/PE	1/N/PE	1/N/PE	1/N/PE	1/N/PE
Max. operating current	A	8.4	13	15.09	24.32	24.48
Versions						
Refrigerant		R454 C	R454 C	R454 C	R454 C	R454 C
Refrigerant charge	kg	2.2	2.2	2.2	3.1	3.1
Global warming potential of the refrigerant (GWP100)		148	148	148	148	148
CO ₂ equivalent (CO ₂ e)	t	0.32	0.32	0.32	0.45	0.45
Condenser material		1.4401/Cu	1.4401/Cu	1.4401/Cu	1.4401/Cu	1.4401/Cu
Evaporator material		1.4401/Cu	1.4401/Cu	1.4401/Cu	1.4401/Cu	1.4401/Cu
Circulation pump type, heating side		Yonos PARA 25/7.0	Yonos PARA 25/7.0	Yonos PARA 25/7.0	Yonos PARA 25/7.5	Yonos PARA 25/7.5
Circulation pump type, source side		Grundfos UPML	Grundfos UPML	Grundfos UPML	Grundfos UPML	Grundfos UPML
IP rating		IP20	IP20	IP20	IP20	IP20

INSTALLATION Specification

		HPG-I 04 CS Premium	HPG-I 06 CS Premium	HPG-I 08 CS Premium	HPG-I 12 CS Premium	HPG-I 15 CS Premium
Dimensions						
Height	mm	1369	1369	1369	1369	1369
Width	mm	598	598	598	598	598
Depth	mm	658	658	658	658	658
Weights						
Weight	kg	180	180	180	190	190
Connections						
DHW flow/return push-fit connection		28 mm	28 mm	28 mm	28 mm	28 mm
Heat source flow/return push-fit connection		28 mm	28 mm	28 mm	28 mm	28 mm
Heating flow/return push-fit connection		28 mm	28 mm	28 mm	28 mm	28 mm
Heating water quality requirements						
Water hardness	°dH	≤3	≤3	≤3	≤3	≤3
pH value (with aluminium fittings)		8.0-8.5	8.0-8.5	8.0-8.5	8.0-8.5	8.0-8.5
pH value (without aluminium fittings)		8.0-10.0	8.0-10.0	8.0-10.0	8.0-10.0	8.0-10.0
Chloride	mg/l	< 30	< 30	< 30	< 30	< 30
Conductivity (desalination)	µS/cm	20-100	20-100	20-100	20-100	20-100
Conductivity (softening)	µS/cm	< 1000	< 1000	< 1000	< 1000	< 1000
Oxygen 8-12 weeks after filling (softening)	mg/l	< 0.02	< 0.02	< 0.02	< 0.02	< 0.02
Oxygen 8-12 weeks after filling (desalination)	mg/l	< 0.1	< 0.1	< 0.1	< 0.1	< 0.1
Heat transfer medium requirements on the heat source side						
Ethylene glycol concentration, geothermal probe	Vol.-%	25	25	25	25	25
Ethylene glycol concentration, geothermal collector	Vol.-%	33	33	33	33	33
Values						
Min. flow rate, heating	m ³ /h	0.3	0.3	0.3	0.3	0.3
Heating flow rate (EN 14511) at A7/W35, B0/W35 and 5 K	m ³ /h	0.34	0.41	0.48	0.74	0.9
Heating flow rate max. at B0/W35 and 8 K	m ³ /h	0.45	0.71	0.81	1.36	1.59
Available external pressure differential, heating, max. at B0/W35 and 8 K	hPa	708	642	603	571	462
flow rate on heat source side at B0/W35 and 3 K	m ³ /h	0.5	0.6	0.68	1.08	1.31
Max. flow rate on heat source side at B0/W35 and 3 K	m ³ /h	1.05	1.61	1.82	3.1	3.55
Max. available external pressure differential on heat source side at B0/W35 and 3 K	hPa	927	702	590	319	74
Internal volume, heating side	l	28.4	28.4	28.4	29.1	29.1
Internal volume, source side	l	26.5	26.5	26.5	27.9	27.9
Expansion vessel pre-charge pressure on the heating side	MPa	0.15	0.15	0.15	0.15	0.15
Expansion vessel volume on the heating side	l	24	24	24	24	24
Expansion vessel pre-charge pressure on the source side	MPa	0.05	0.05	0.05	0.05	0.05
Expansion vessel volume on the source side	l	24	24	24	24	24

Conversion: 1 m³/h = 16.67 l/min

Further details

		HPG-I 04 CS Premium	HPG-I 06 CS Premium	HPG-I 08 CS Premium	HPG-I 12 CS Premium	HPG-I 15 CS Premium
		202627	202628	202629	202630	202631
Maximum altitude for installation	m	2000	2000	2000	2000	2000

Guarantee

The guarantee conditions of our German companies do not apply to appliances acquired outside of Germany. In countries where our subsidiaries sell our products a guarantee can only be issued by those subsidiaries. Such guarantee is only granted if the subsidiary has issued its own terms of guarantee. No other guarantee will be granted.

We shall not provide any guarantee for appliances acquired in countries where we have no subsidiary to sell our products. This will not affect warranties issued by any importers.

Environment and recycling

We would ask you to help protect the environment. After use, dispose of the various materials in accordance with national regulations.

NOTES

Deutschland

STIEBEL ELTRON GmbH & Co. KG
Dr.-Stiebel-Straße 33 | 37603 Holzminden
Tel. 05531 702-0 | Fax 05531 702-480
info@stiebel-eltron.de
www.stiebel-eltron.de

Verkauf

Kundendienst
Ersatzteilverkauf

Tel. 05531 702-110 | Fax 05531 702-95108 | info-center@stiebel-eltron.de
Tel. 05531 702-111 | Fax 05531 702-95890 | kundendienst@stiebel-eltron.de
www.stiebel-eltron.de/ersatzteile | ersatzteile@stiebel-eltron.de

Australia

STIEBEL ELTRON Australia Pty. Ltd.
294 Salmon Street | Port Melbourne VIC 3207
Tel. 03 9645-1833 | Fax 03 9644-5091
info@stiebel-eltron.com.au
www.stiebel-eltron.com.au

Austria

STIEBEL ELTRON Ges.m.b.H.
Gewerbegebiet Neubau-Nord
Margaritenstraße 4 A | 4063 Hörsching
Tel. 07221 74600-0 | Fax 07221 74600-42
info@stiebel-eltron.at
www.stiebel-eltron.at

Belgium

STIEBEL ELTRON bvba/sprl
't Hofveld 6 - D1 | 1702 Groot-Bijgaarden
Tel. 02 42322-22 | Fax 02 42322-12
info@stiebel-eltron.be
www.stiebel-eltron.be

China

STIEBEL ELTRON (Tianjin) Electric Appliance Co., Ltd.
Plant C3, XEDA International Industry City
Xiqing Economic Development Area
300385 Tianjin
Tel. 022 8396 2077 | Fax 022 8396 2075
info@stiebeleltron.cn
www.stiebeleltron.cn

Czech Republic

STIEBEL ELTRON spol. s r.o.
Dopraváků 749/3 | 184 00 Praha 8
Tel. 251116-111 | Fax 235512-122
info@stiebel-eltron.cz
www.stiebel-eltron.cz

Finland

STIEBEL ELTRON OY
Kapinakuja 1 | 04600 Mäntsälä
Tel. 020 720-9988
info@stiebel-eltron.fi
www.stiebel-eltron.fi

France

STIEBEL ELTRON SAS
7-9, rue des Selliers
B.P 85107 | 57073 Metz-Cédex 3
Tel. 0387 7438-88 | Fax 0387 7468-26
info@stiebel-eltron.fr
www.stiebel-eltron.fr

Hungary

STIEBEL ELTRON Kft.
Gyár u. 2 | 2040 Budaörs
Tel. 01 250-6055 | Fax 01 368-8097
info@stiebel-eltron.hu
www.stiebel-eltron.hu

Japan

NIHON STIEBEL Co. Ltd.
Kowa Kawasaki Nishiguchi Building 8F
66-2 Horikawa-Cho
Saiwai-Ku | 212-0013 Kawasaki
Tel. 044 540-3200 | Fax 044 540-3210
info@nihonstiebel.co.jp
www.nihonstiebel.co.jp

Netherlands

STIEBEL ELTRON Nederland B.V.
Daviottenweg 36 | 5222 BH 's-Hertogenbosch
Tel. 073 623-0000 | Fax 073 623-1141
info@stiebel-eltron.nl
www.stiebel-eltron.nl

New Zealand

Stiebel Eltron NZ Limited
61 Barrys Point Road | Auckland 0622
Tel. +64 9486 2221
info@stiebel-eltron.co.nz
www.stiebel-eltron.co.nz

Poland

STIEBEL ELTRON Polska Sp. z O.O.
ul. Działkowa 2 | 02-234 Warszawa
Tel. 022 60920-30 | Fax 022 60920-29
biuro@stiebel-eltron.pl
www.stiebel-eltron.pl

Russia

STIEBEL ELTRON LLC RUSSIA
Urzhumskaya street 4,
building 2 | 129343 Moscow
Tel. +7 495 125 0 125
info@stiebel-eltron.ru
www.stiebel-eltron.ru

Slovakia

STIEBEL ELTRON Slovakia, s.r.o.
Hlavná 1 | 058 01 Poprad
Tel. 052 7127-125 | Fax 052 7127-148
info@stiebel-eltron.sk
www.stiebel-eltron.sk

South Africa

STIEBEL ELTRON Southern Africa (PTY) Ltd
30 Archimedes Road
Wendywood
Johannesburg, 2090
Tel. +27 10 001 85 47
info@stiebel-eltron.co.za
www.stiebel-eltron.co.za

Switzerland

STIEBEL ELTRON AG
Industrie West
Gass 8 | 5242 Lupfig
Tel. 056 4640-500 | Fax 056 4640-501
info@stiebel-eltron.ch
www.stiebel-eltron.ch

Thailand

STIEBEL ELTRON Asia Ltd.
469 Moo 2 Tambol Klong-Jik
Amphur Bangpa-In | 13160 Ayutthaya
Tel. 035 220088 | Fax 035 221188
info@stiebeleltronasia.com
www.stiebeleltronasia.com

United Kingdom and Ireland

STIEBEL ELTRON UK Ltd.
Unit 12 Stadium Court
Stadium Road | CH62 3RP Bromborough
Tel. 0151 346-2300 | Fax 0151 334-2913
info@stiebel-eltron.co.uk
www.stiebel-eltron.co.uk

United States of America

STIEBEL ELTRON, Inc.
17 West Street | 01088 West Hatfield MA
Tel. 0413 247-3380 | Fax 0413 247-3369
info@stiebel-eltron-usa.com
www.stiebel-eltron-usa.com

STIEBEL ELTRON



Irrtum und technische Änderungen vorbehalten! | Subject to errors and technical changes! | Sous réserve d'erreurs et de modifications techniques! | Onder voorbehoud van vergissingen en technische wijzigingen! | Salvo error o modificación técnica! | Excepto erro ou alteração técnica | Zastrzeżone zmiany techniczne i ewentualne błędy | Omyly a technické změny jsou vyhrazeny! | A muszaki változtatások és tévedések jogát fenntartjuk! | Отсутствие ошибок не гарантируется. Возможны технические изменения. | Chyby a technické zmeny sú vyhradené! | Stand 9734